



SUPERSERVER[®] SYS-240P-TNRT



USER'S MANUAL

Revision 1.0b

The information in this User's Manual has been carefully reviewed and is believed to be accurate. The vendor assumes no responsibility for any inaccuracies that may be contained in this document, and makes no commitment to update or to keep current the information in this manual, or to notify any person or organization of the updates. Please Note: For the most up-to-date version of this manual, please see our website at www.supermicro.com.

Super Micro Computer, Inc. ("Supermicro") reserves the right to make changes to the product described in this manual at any time and without notice. This product, including software and documentation, is the property of Supermicro and/or its licensors, and is supplied only under a license. Any use or reproduction of this product is not allowed, except as expressly permitted by the terms of said license.

IN NO EVENT WILL Super Micro Computer, Inc. BE LIABLE FOR DIRECT, INDIRECT, SPECIAL, INCIDENTAL, SPECULATIVE OR CONSEQUENTIAL DAMAGES ARISING FROM THE USE OR INABILITY TO USE THIS PRODUCT OR DOCUMENTATION, EVEN IF ADVISED OF THE POSSIBILITY OF SUCH DAMAGES. IN PARTICULAR, SUPER MICRO COMPUTER, INC. SHALL NOT HAVE LIABILITY FOR ANY HARDWARE, SOFTWARE, OR DATA STORED OR USED WITH THE PRODUCT, INCLUDING THE COSTS OF REPAIRING, REPLACING, INTEGRATING, INSTALLING OR RECOVERING SUCH HARDWARE, SOFTWARE, OR DATA.

Any disputes arising between manufacturer and customer shall be governed by the laws of Santa Clara County in the State of California, USA. The State of California, County of Santa Clara shall be the exclusive venue for the resolution of any such disputes. Supermicro's total liability for all claims will not exceed the price paid for the hardware product.

FCC Statement: This equipment has been tested and found to comply with the limits for a Class A or Class B digital device pursuant to Part 15 of the FCC Rules. These limits are designed to provide reasonable protection against harmful interference when the equipment is operated in industrial environment for Class A device or in residential environment for Class B device. This equipment generates, uses, and can radiate radio frequency energy and, if not installed and used in accordance with the manufacturer's instruction manual, may cause harmful interference with radio communications. Operation of this equipment in a residential area is likely to cause harmful interference, in which case you will be required to correct the interference at your own expense.

California Best Management Practices Regulations for Perchlorate Materials: This Perchlorate warning applies only to products containing CR (Manganese Dioxide) Lithium coin cells. "Perchlorate Material-special handling may apply. See www.dtsc.ca.gov/hazardouswaste/perchlorate".



WARNING: This product can expose you to chemicals including lead, known to the State of California to cause cancer and birth defects or other reproductive harm. For more information, go to www.P65Warnings.ca.gov.

The products sold by Supermicro are not intended for and will not be used in life support systems, medical equipment, nuclear facilities or systems, aircraft, aircraft devices, aircraft/emergency communication devices or other critical systems whose failure to perform be reasonably expected to result in significant injury or loss of life or catastrophic property damage. Accordingly, Supermicro disclaims any and all liability, and should buyer use or sell such products for use in such ultra-hazardous applications, it does so entirely at its own risk. Furthermore, buyer agrees to fully indemnify, defend and hold Supermicro harmless for and against any and all claims, demands, actions, litigation, and proceedings of any kind arising out of or related to such ultra-hazardous use or sale.

Manual Revision 1.0b

Release Date: May 04, 2023

Unless you request and receive written permission from Super Micro Computer, Inc., you may not copy any part of this document. Information in this document is subject to change without notice. Other products and companies referred to herein are trademarks or registered trademarks of their respective companies or mark holders.

Copyright © 2023 by Super Micro Computer, Inc.
All rights reserved.

Printed in the United States of America

Preface

About this Manual

This manual is written for professional system integrators and PC technicians. It provides information for the installation and use of the server. Installation and maintenance should be performed by experienced technicians only.

Please refer to the SYS-240P-TNRT server specifications page on our website for updates on supported memory, processors and operating systems (<http://www.supermicro.com>).

Notes

For your system to work properly, please follow the links below to download all necessary drivers/utilities and the user's manual for your server.

- Supermicro product manuals: <http://www.supermicro.com/support/manuals/>
- Product drivers and utilities: <https://www.supermicro.com/wdl/driver>
- Product safety info: http://www.supermicro.com/about/policies/safety_information.cfm

If you have any questions, please contact our support team at:
support@supermicro.com

This manual may be periodically updated without notice. Please check the Supermicro website for possible updates to the manual revision level.

Secure Data Deletion

A secure data deletion tool designed to fully erase all data from storage devices can be found on our website: https://www.supermicro.com/about/policies/disclaimer.cfm?url=/wdl/utility/Lot9_Secure_Data_Deletion_Utility/

Warnings

Special attention should be given to the following symbols used in this manual.



Warning! Indicates important information given to prevent equipment/property damage or personal injury.



Warning! Indicates high voltage may be encountered when performing a procedure.

Contents

Contacting Supermicro.....	8
Chapter 1 Introduction	
1.1 Overview.....	9
1.2 System Features	10
Front View	10
Drive Carrier Indicators.....	10
Control Panel.....	11
Rear View.....	12
1.3 System Architecture	14
Main Components	14
System Block Diagram.....	15
1.4 Motherboard Layout	16
Quick Reference Table.....	17
Chapter 2 Server Installation	
2.1 Overview.....	19
2.2 Unpacking the System	19
2.3 Preparing for Setup.....	19
Choosing a Setup Location.....	19
Rack Precautions	20
Server Precautions.....	20
Rack Mounting Considerations	20
Ambient Operating Temperature.....	20
Airflow	21
Mechanical Loading.....	21
Circuit Overloading	21
Reliable Ground.....	21
2.4 Installing the Rails	22
Installing the Inner Rails	22
Installing the Outer Rails onto the Rack.....	23
2.5 Installing the Chassis into a Rack.....	24
Removing the Chassis from the Rack	25

Chapter 3 Maintenance and Component Installation

3.1	Powering Down the System	26
3.2	Accessing the System.....	27
	Removing the Top Cover.....	27
3.3	Static-Sensitive Devices.....	28
	Precautions	28
3.4	Processor and Heatsink Installation.....	29
	The Processor Carrier Assembly	30
	The Processor Heatsink Module (PHM).....	32
	Preparing the CPU Socket for Installation.....	33
	Installing the PHM into the CPU Socket.....	34
	Removing the PHM from the CPU Socket	36
	Removing the Processor Carrier Assembly from the PHM	37
	Removing the Processor from the Processor Carrier Assembly	38
3.5	Memory.....	39
	Memory Support.....	39
	Memory Installation Sequence.....	39
	General Memory Population Requirements.....	39
	DDR4 Memory Population Table	40
	Memory Population Sequence for Half Memory Configuration.....	40
	Memory Population Table with Full Memory Configuration.....	40
	Intel® Optane™ PMem 200 Series Memory Population (Full Configuration).....	40
	DIMM Installation	42
	DIMM Removal	42
3.6	Motherboard Battery.....	43
3.7	Storage Drives.....	44
	Checking the Temperature of an NVMe Drive.....	44
	Installing Drives.....	44
	Hot-Swap for NVMe Drives.....	46
	Installing M.2 Solid State Drives	47
	Installing M.2 Drives	47
3.8	System Cooling	48
	Fans	48
	Air Shrouds	49

3.9 Expansion Cards	52
Installing Expansion Cards	52
3.10 Power Supply	53
3.11 Cable Routing Diagram	54
3.12 BMC	55

Chapter 4

Motherboard Connections

4.1 Power Connections	56
4.2 Headers and Connectors	57
Control Panel	59
4.3 Input/Output Ports	62
Rear I/O Ports	62
4.4 Jumpers	64
4.5 LED Indicators	67
4.6 Storage Ports	69

Chapter 5 Software

5.1 Microsoft Windows OS Installation	70
5.2 Driver Installation	72
5.3 SuperDoctor® 5	73
5.4 BMC	74
BMC ADMIN User Password	74

Chapter 6 Optional Components

6.1 Optional Parts List	75
6.2 Storage Control Cards	76
6.3 Network Cards	76
6.4 Intel Virtual RAID on CPU (VROC)	77
Requirements and Restrictions	77
Supported SSDs and Operating Systems	77
Additional Information	78
Hardware Key	78
Enabling NVMe RAID	79
Status Indications	82
Hot Swap Drives	82
Hot-unplug	82

Hot-plug	82
Chapter 7 Troubleshooting and Support	
7.1 Information Resources	83
Website	83
Direct Links for the SYS-240P-TNRT System.....	83
Direct Links for General Support and Information	83
7.2 Baseboard Management Controller Interface	84
7.3 Troubleshooting Procedures	85
No Power	85
No Video	86
System Boot Failure	86
Memory Errors	86
Losing the System's Setup Configuration.....	86
When the System Becomes Unstable	86
7.4 BIOS Error Beep (POST) Codes	88
Additional BIOS POST Codes	88
7.5 Crash Dump Using BMC.....	89
7.6 UEFI BIOS Recovery	90
Overview	90
Recovering the UEFI BIOS Image.....	90
Recovering the Main BIOS Block with a USB Device.....	90
7.7 CMOS Clear	95
7.8 Where to Get Replacement Components	96
7.9 Reporting an Issue	96
Technical Support Procedures	96
Returning Merchandise for Service.....	96
Vendor Support Filing System	97
7.10 Feedback.....	97
7.11 Contacting Supermicro.....	98
Appendix A Standardized Warning Statements for AC Systems	
Appendix B System Specifications	
Appendix C BSMI Chinese Safety Warnings	

Contacting Supermicro

Headquarters

Address: Super Micro Computer, Inc.
980 Rock Ave.
San Jose, CA 95131 U.S.A.

Tel: +1 (408) 503-8000

Fax: +1 (408) 503-8008

Email: marketing@supermicro.com (General Information)
Sales-USA@supermicro.com (Sales Inquiries)
Government_Sales-USA@supermicro.com (Gov. Sales Inquiries)
support@supermicro.com (Technical Support)
RMA@supermicro.com (RMA Support)
Webmaster@supermicro.com (Webmaster)

Website: www.supermicro.com

Europe

Address: Super Micro Computer B.V.
Het Sterrenbeeld 28, 5215 ML
's-Hertogenbosch, The Netherlands

Tel: +31 (0) 73-6400390

Fax: +31 (0) 73-6416525

Email: Sales_Europe@supermicro.com (Sales Inquiries)
Support_Europe@supermicro.com (Technical Support)
RMA_Europe@supermicro.com (RMA Support)

Website: www.supermicro.nl

Asia-Pacific

Address: Super Micro Computer, Inc.
3F, No. 150, Jian 1st Rd.
Zhonghe Dist., New Taipei City 235
Taiwan (R.O.C)

Tel: +886-(2) 8226-3990

Fax: +886-(2) 8226-3992

Email: Sales-Asia@supermicro.com.tw (Sales Inquiries)
Support@supermicro.com.tw (Technical Support)
RMA@supermicro.com.tw (RMA Support)

Website: www.supermicro.com.tw

Chapter 1

Introduction

1.1 Overview

This chapter provides a brief outline of the functions and features of the SuperServer SYS-240P-TNRT. It is based on the X12QCH+-P motherboard and the CSE-218HTS-R2K08P chassis.

The following provides an overview of the specifications and capabilities.

System Overview	
Motherboard	X12QCH+-P
Chassis	CSE-218HTS-R2K08P
Processor Support*	3rd Generation Intel® Xeon® Scalable processors
Memory*	48 DIMM slots for up to 12TB 3DS ECC DDR4-3200:RDIMM/LRDIMM or 18TB Intel® Optane™ DDR4-2666:DCPMM, RDIMM/LRDIMM//DCPMM
Drive Support*	24 hot-swap 2.5" NVMe/SAS3/SATA3 drive bays Four optional rear 2.5" bays SAS/SATA Two M.2 SATA3
Expansion Slots*	Up to 6 single-wide PCIe 3.0 (4 x16 + 2 x8) slots Up to 2 double-wide PCIe 3.0 x16 slots for GPUs
I/O Ports*	Two 10G BaseT with Intel® X710-TM4 Two 10G SFP+ with Intel X710-TM4 (Optional): AIOM up to 100G QSFP 28 One BMC port One VGA port One serial (COM) port Two rear USB 3.0 ports One USB 3.0 Type A header
System Cooling*	Four 8-cm heavy duty fans
Power	Two redundant power supply modules 2000W (Titanium Level)
Form Factor	2U: 3.5 x 17.3 x 31.6in. / 89 x 439.5 x 803mm (HxWxD)

Notes: A Quick Reference Guide can be found on the product page of the Supermicro website.

The following safety models associated with the SYS-240P-TNRT have been certified as compliant with UL or CSA: 218H-MP4, 218H-20, 218H-R20X12.

1.2 System Features

The following views of the system display the main features. Refer to [Appendix B](#) for additional specifications.

Front View



Figure 1-1. Front View

Logical Storage Drive Numbers	
Item	Description
0-23	24 hot-swap 2.5" NVMe Gen4/SAS3/SATA3 drive bays (hybrid)

Drive Carrier Indicators

Each drive carrier has two LED indicators: an activity indicator and a status indicator. For RAID configurations using a controller, the meaning of the status indicator is described in the table below. For OS RAID or non-RAID configurations, some LED indications are not supported, such as hot spare. For VROC configurations, refer to the VROC appendix in this manual.

Drive Carrier LED Indicators			
	Color	Blinking Pattern	Behavior for Device
Activity LED	Blue	Solid On	Idle SAS/NVMe drive installed
	Blue	Blinking	I/O activity
	Off		Idle SATA drive
Status LED	Red	Solid On	Failure of drive with RSTe support
	Red	Blinking at 1 Hz	Rebuild drive with RSTe support
	Red	Blinking with two blinks and one stop at 1 Hz	Hot spare for drive with RSTe support
	Red	On for five seconds, then off	Power on for drive with RSTe support
	Red	Blinking at 4 Hz	Identify drive with RSTe support

Control Panel

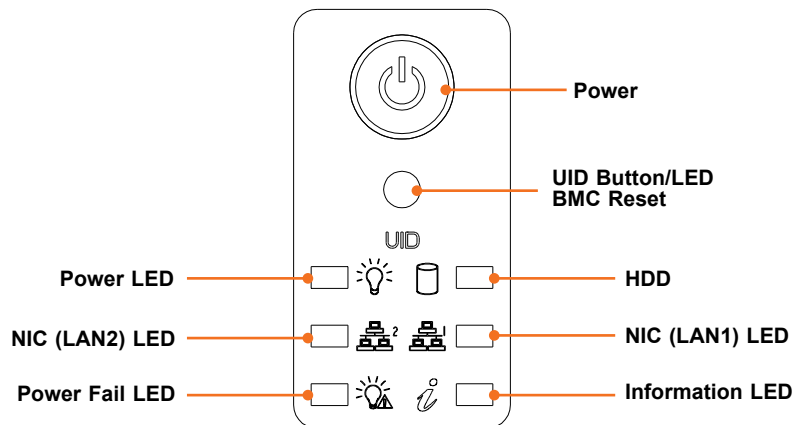

Figure 1-2. Control Panel

Control Panel Features	
Feature	Description
Power button	The main power switch applies or removes primary power from the power supply to the server but maintains standby power.
UID button/LED BMC button	The unit identification (UID) button turns on or off the blue light function of the Information LED and a blue LED on the rear of the chassis. This button can also be used to reset the BMC. See Chapter 3.
Power LED	Indicates power is being supplied to the system power supply units. This LED is illuminated when the system is operating normally.
HDD	Indicates activity on the storage drives when flashing.
NIC (LAN1) LED	Indicates network activity on LAN1 when flashing.
NIC (LAN2) LED	Indicates network activity on LAN2 when flashing.
Power Fail LED	Indicates a power supply module has failed.
Information LED	Alerts operator to several states, as noted in the table below.

Information LED	
Color, Status	Description
Red, solid	An overheat condition has occurred.
Red, blinking at 1Hz	Fan failure, check for an inoperative fan.
Red, blinking at 0.25Hz	Power failure, check for a non-operational power supply.
Red, solid, with Power LED blinking green	Fault detected
Blue and red, blinking at 10 Hz	Recovery mode
Blue, solid	UID has been activated locally to locate the server in a rack environment.
Blue, blinking at 1Hz	UID has been activated using the BMC to locate the server in a rack environment.
Blue, blinking at 2Hz	BMC is resetting
Blue, blinking at 4Hz	BMC is setting factory defaults
Blue, blinking at 10Hz with Power LED blinking green	BMC/BIOS firmware is updating

Rear View

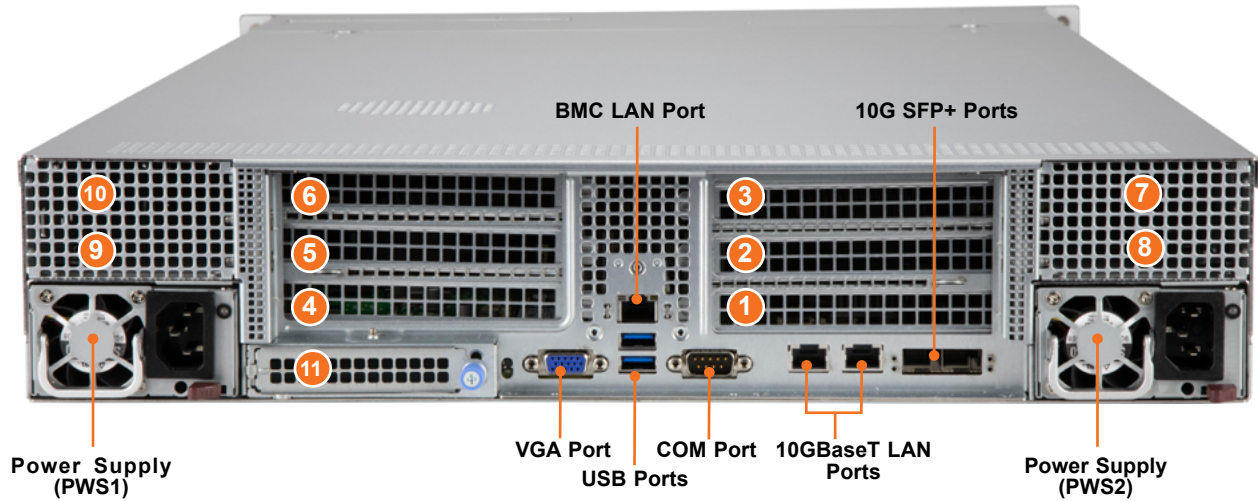

Figure 1-3. System: Rear View

Expansion Slot Locations		
Item	Description	Associated Riser Card
1	PCIe 3.0 x16 signal in x16 slot (FHHL)	RSC-D2-668G4
2	PCIe 3.0 x8 signal in x16 slot (FHFL)	RSC-D2-668G4
3	PCIe 3.0 x16 signal in x16 slot (FHFL)	RSC-D2-668G4
4	PCIe 3.0 x16 signal in x16 slot (FHHL)	RSC-D2R-668G4
5	PCIe 3.0 x16 signal in x16 slot (FHFL)	RSC-D2R-668G4
6	PCIe 3.0 x8 signal in x16 slot (FHFL)	RSC-D2R-668G4
7	PCIe 3.0 x16 signal in x16 slot (HHHL)	RSC-H2-68G4 (optional)
8	PCIe 3.0 x8 signal in x16 slot (HHHL)	RSC-H2-68G4 (optional)
9	PCIe 3.0 x16 signal in x16 slot (HHHL)	RSC-H2-68G4 (optional)
10	PCIe 3.0 x8 signal in x16 slot (HHHL)	RSC-H2-68G4 (optional)
11	PCIe 3.0 x16 AIOM (OCP) slot	N/A

Notes: FHFL = full height, full length. FHHL = full height, half length. HHHL = half height, half length.

Full height = 4.2", low profile = 2.5", full length = 10.5", half length = 6.6"

System Features: Rear	
Feature	Description
Power Supplies	Two (redundant) power supply modules, PWS1 on the left, PWS2 on the right
LAN Ports	Two 10GBaseT and two 10G SFP+ LAN ports (see Section 1.1 for details)
USB	Two USB 3.0 ports
BMC LAN Port	Dedicated BMC LAN port
COM Port	Serial port
VGA Port	Video port

Power Supply Indicators		
Power Supply Condition	Green LED	Amber LED
No AC Power to Power Supply	OFF	OFF
Power Supply critical events causing a shutdown/ failure/ OCP/ OVP/ Fan Fail/ OTP/ UVP	OFF	Amber LED
Power Supply Warning Events Where the power supply continues to operate; High temperature; Over voltage; under voltage, etc	OFF	1Hz Blink Amber
AC present only 12vsb on (PS off)	1Hz Blink Green	OFF
Output ON and OK	Green	OFF
AC cord unplugged and in redundant mode	OFF	Amber

1.3 System Architecture

This section covers the locations of the system electrical components, a system block diagram, and a motherboard layout with the connectors and jumpers called out.

Main Components

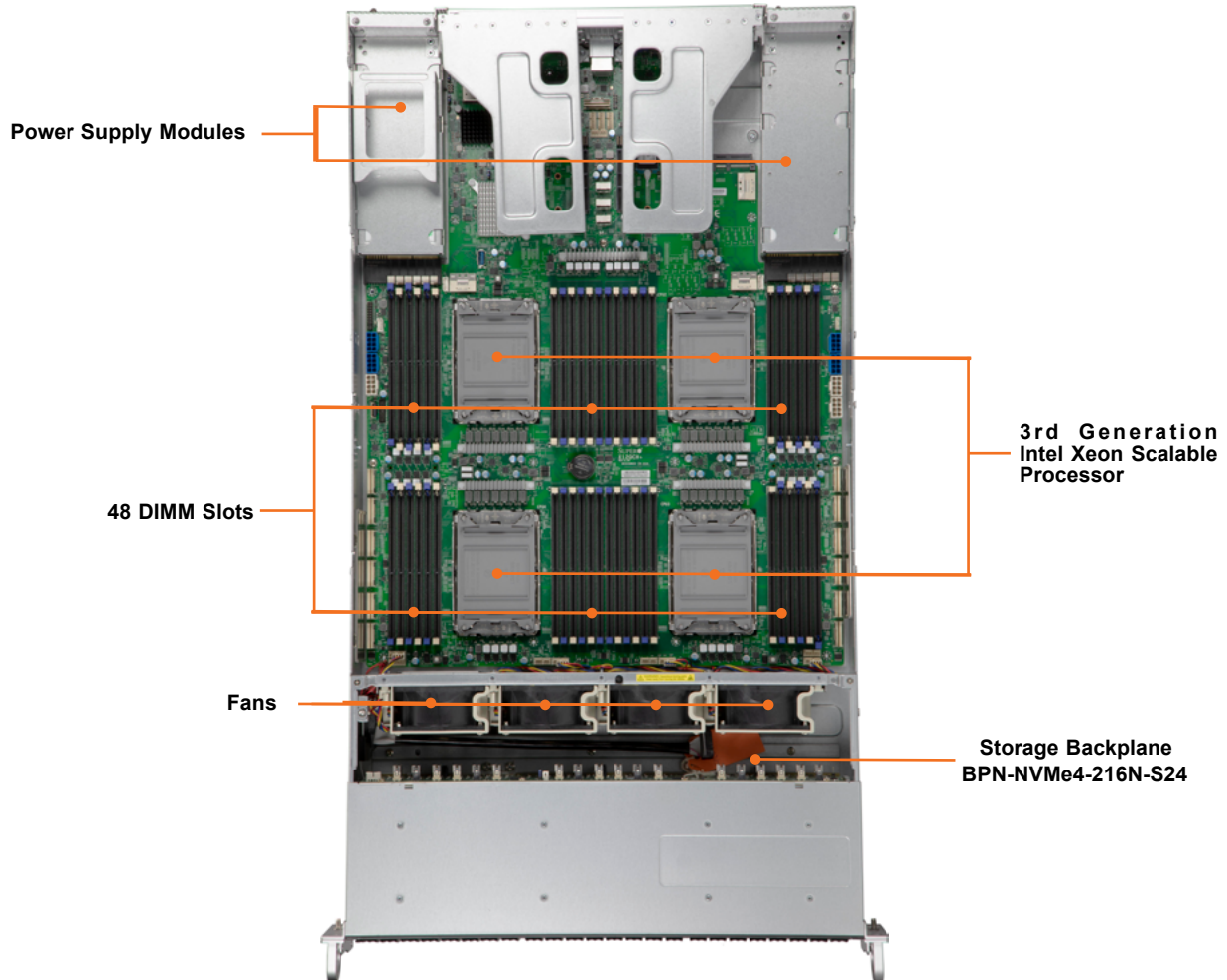

Figure 1-4. Main Component Locations

System Features: Top	
Feature	Description
Power Supplies	Dual (redundant) power supply modules
Storage Backplane	Disk-on-Module port allows for flash cards to be mounted directly on the motherboard
DIMM slots	Dual in-line memory module slots
Processors	Onboard 3rd Generation Intel® Xeon® Scalable processors
System fans	8-cm heavy duty fans

System Block Diagram

The block diagram below shows the connections and relationships between the subsystems and major components of the overall system.

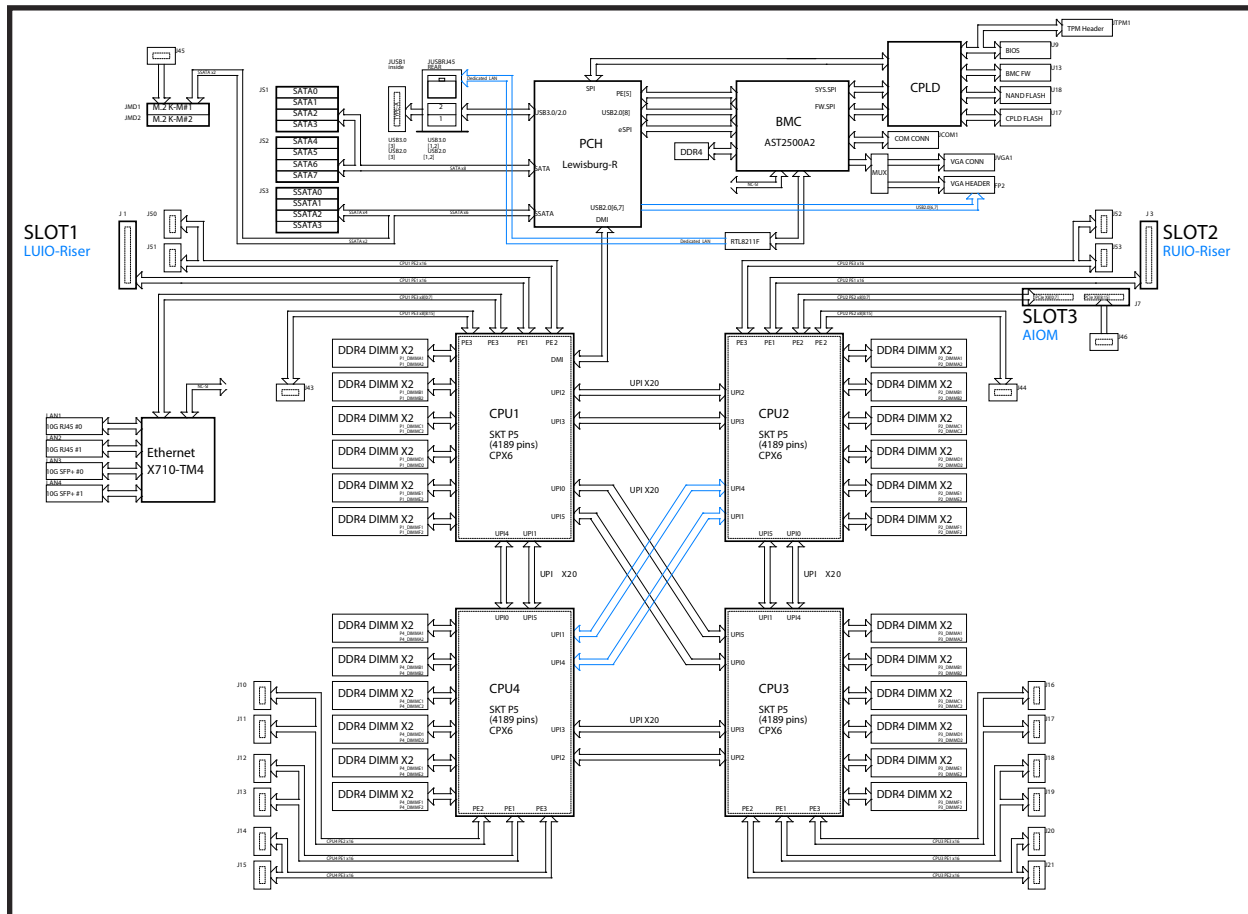

Figure 1-5. System Block Diagram

Quick Reference Table

Jumper	Description	Default Setting
J34	Power-Failure Throttling Enable	Pins 1-2 (Normal)
J58	Select Switch for FP1_Reset Button or UID Button	Closed (UID)
JBT1	Clear CMOS	Open (Normal)
JPME2	Manufacturing Mode (ME) Select	Pins 1-2 (Normal)
JPTG1	10G LAN Enable/Disable	Pins 1-2 (Enabled)
JWD1	Watch Dog Timer Enable	Pins 1-2 (Reset to System)

LED	Description	Status
BMC_HB_LED1	BMC Heartbeat LED	Blinking Green: BMC Normal
LED1	Unit Identifier (UID) LED	Solid Blue: Unit Identified
LED2	Onboard Power LED	Solid Green: Power On
LEDT1	10G LAN Activity LED	Green: LAN4: Active
LEDT2	10G LAN Activity LED	Green: LAN3: Active

Connector	Description
AIOM1 (J46)	PCIe 3.0 x8 AIOM (Advanced I/O Module) slot
Battery (JBAT1)	Onboard CMOS battery
COM1 (JCOM1)	Rear I/O COM port
FAN1 - FAN12	System cooling fan headers
FP1	Front Control Panel header with I ² C
FP2	Front Control Panel header with USB and VGA support
IPMB (JIPMB1)	4-pin BMC External I ² C header (for an BMC-supported card)
BMC_LAN (JUSBRJ45)	Dedicated BMC LAN port
J5/J6	6-pin power connector used for PCIe 3.0 x16 HIO left side slot (P1_HIO_L1PCIE) (J5)/ power connector for right side slot (P2_HIO_R1PCIE) (J6)
J26/J47	PDB (Power Delivery Board) cable connector for CPU3 (J47)/PDB cable connector for CPU4 (J26)
JF1	Front Control Panel header
JL1	Chassis Intrusion header
BP_PWR1/2/3	8-pin power connectors 1/2/3 used for backplane devices
GPU_PWR1/2/3/4	8-pin power connectors 1/2/3/4 for GPU use
JSTBY1	5V standby power header
JTPM1	Trusted Platform Module/Port 80 connector
LAN1, LAN2 (JLAN1, JLAN2)	Ethernet (RJ45) 10G LAN Port1/10G LAN Port2
LAN3, LAN4 (JLAN3, JLAN4)	10G LAN Port3/10G LAN Port4 (w/SFP28 support)
P2_AIOM PCIe 3.0 x16 Slot (J7)	PCIe 3.0 x16 AIOM slot supported by CPU2 (J7)
P1_HIO_L1PCIE/P2_HIO_R1PCIE	PCIe 3.0 x16 HIO (High_Speed I/O) left_side slot supported by CPU1/PCIe 3.0 x16 HIO right_side slot supported by CPU2
P1_PCIE2A/P1_PCIE2B (J50/J51)	SMCI_proprietary PCIe 3.0 x8 slots supported by CPU1
P2_PCIE3A/P1_PCIE3B (J52/J53)	SMCI_proprietary PCIe 3.0 x8 slots supported by CPU2
P1_PCIE3B/P2_PCIE2A (J43/J44)	PCIe 3.0 x8 slots supported by CPU1 (J43) & CPU2 (J44)

P3-PCIE1A/1B/2A/2B/3A/3B	PCIe 3.0 x8 slots supported by CPU3 (J19/J18/J21/J20/J17/J16)
P4-PCIE1A/1B/2A/2B/3A/3B	PCIe 3.0 x8 slots supported by CPU4 (J12/J13/J10/J11/J14/J15)
PDB_I2C1/PDB_I2C2 (PSU1/ PSU2)	PDB (Power Delivery Board) I ² C1 (PSU1)/PDB I ² C2 (PSU2)
PCIE M.2	PCIe 3.0 x4 M.2 slot (with 2280 and 22110 support)
(I-)SATA 0-3, (I-)SATA 4-7	Intel® PCH SATA 3.0 connectors 0-3, 4-7 (with RAID 0, 1, 5, 10)
(S-)SATA 0-3	S-SATA 3.0 Connector 0-3 (supported by Intel PCH)
(M.2-HC) S-SATA 4/5 (JMD1/ JMD2)	PCIe 3.0 x4 M.2 slots for NVMe/SATA SSDs (with support of M-Key 2280, and 22110 via SlimSAS x8 cables)
UID (JUIDB1)	Unit Identifier (UID) button
USB0/1 (3.0) (JUSBRJ45)	Rear I/O USB 3.0 ports 0/1
USB2 (3.0) (JUSB1)	Internal Type A USB 3.0 header
VGA (JVGA1)	Rear VGA port on the I/O backpanel
VROC (JRK1)	Intel VROC key header for NVMe RAID support

Chapter 2

Server Installation

2.1 Overview

This chapter provides advice and instructions for mounting your system in a server rack. If your system is not already fully integrated with processors, system memory etc., refer to [Chapter 3](#) for details on installing those specific components.

Caution: Electrostatic Discharge (ESD) can damage electronic components. To prevent such damage to PCBs (printed circuit boards), it is important to use a grounded wrist strap, handle all PCBs by their edges and keep them in anti-static bags when not in use.

2.2 Unpacking the System

Inspect the box in which the SYS-240P-TNRT was shipped, and note if it was damaged in any way. If any equipment appears damaged, file a damage claim with the carrier who delivered it.

Decide on a suitable location for the rack unit that will hold the server. It should be situated in a clean, dust-free area that is well ventilated. Avoid areas where heat, electrical noise and electromagnetic fields are generated. It will also require a grounded AC power outlet nearby. Be sure to read the precautions and considerations noted in [Appendix A](#).

2.3 Preparing for Setup

The box in which the system was shipped should include the rackmount hardware needed to install it into the rack. Please read this section in its entirety before you begin the installation.

Choosing a Setup Location

- The system should be situated in a clean, dust-free area that is well ventilated. Avoid areas where heat, electrical noise and electromagnetic fields are generated.
- Leave enough clearance in front of the rack so that you can open the front door completely (~25 inches) and approximately 30 inches of clearance in the back of the rack to allow sufficient space for airflow and access when servicing.
- This product should be installed only in a Restricted Access Location (dedicated equipment rooms, service closets, etc.).

- This product is not suitable for use with visual display workplace devices according to §2 of the German Ordinance for Work with Visual Display Units.

Rack Precautions

- Ensure that the leveling jacks on the bottom of the rack are extended to the floor so that the full weight of the rack rests on them.
- In single rack installations, stabilizers should be attached to the rack. In multiple rack installations, the racks should be coupled together.
- Always make sure the rack is stable before extending a server or other component from the rack.
- You should extend only one server or component at a time - extending two or more simultaneously may cause the rack to become unstable.

Server Precautions

- Review the electrical and general safety precautions in [Appendix A](#).
- Determine the placement of each component in the rack *before* you install the rails.
- Install the heaviest server components at the bottom of the rack first and then work your way up.
- Use a regulating uninterruptible power supply (UPS) to protect the server from power surges and voltage spikes and to keep your system operating in case of a power failure.
- Allow any drives and power supply modules to cool before touching them.
- When not servicing, always keep the front door of the rack and all covers/panels on the servers closed to maintain proper cooling.

Rack Mounting Considerations

Ambient Operating Temperature

If installed in a closed or multi-unit rack assembly, the ambient operating temperature of the rack environment may be greater than the room's ambient temperature. Therefore, consideration should be given to installing the equipment in an environment compatible with the manufacturer's maximum rated ambient temperature (TMRA).

Airflow

Equipment should be mounted into a rack so that the amount of airflow required for safe operation is not compromised.

Mechanical Loading

Equipment should be mounted into a rack so that a hazardous condition does not arise due to uneven mechanical loading.

Circuit Overloading

Consideration should be given to the connection of the equipment to the power supply circuitry and the effect that any possible overloading of circuits might have on overcurrent protection and power supply wiring. Appropriate consideration of equipment nameplate ratings should be used when addressing this concern.

Reliable Ground

A reliable ground must be maintained at all times. To ensure this, the rack itself should be grounded. Particular attention should be given to power supply connections other than the direct connections to the branch circuit (i.e. the use of power strips, etc.).



To prevent bodily injury when mounting or servicing this unit in a rack, you must take special precautions to ensure that the system remains stable. The following guidelines are provided to ensure your safety:

- This unit should be mounted at the bottom of the rack if it is the only unit in the rack.
- When mounting this unit in a partially filled rack, load the rack from the bottom to the top with the heaviest component at the bottom of the rack.
- If the rack is provided with stabilizing devices, install the stabilizers before mounting or servicing the unit in the rack.
- Slide rail mounted equipment is not to be used as a shelf or a work space.



Slide rail mounted equipment is not to be used as a shelf or a work space.



Warning: do not pick up the server with the front handles. They are designed to pull the system from a rack only.

2.4 Installing the Rails

There are a variety of rack units on the market, which may require a slightly different assembly procedure. This rail set fits a rack between 25.6" and 33" deep.

The following is a basic guideline for installing the system into a rack with the rack mounting hardware provided. You should also refer to the installation instructions that came with the specific rack you are using.

If you are installing into a two-post "telco" rack, skip to that section later in this chapter.

Installing the Inner Rails

The chassis comes with two sets of rack rails, one set for the right side of the chassis and one for the left. Each set consists of an inner rail that attaches to the chassis, and an outer rail that attaches to the rack.

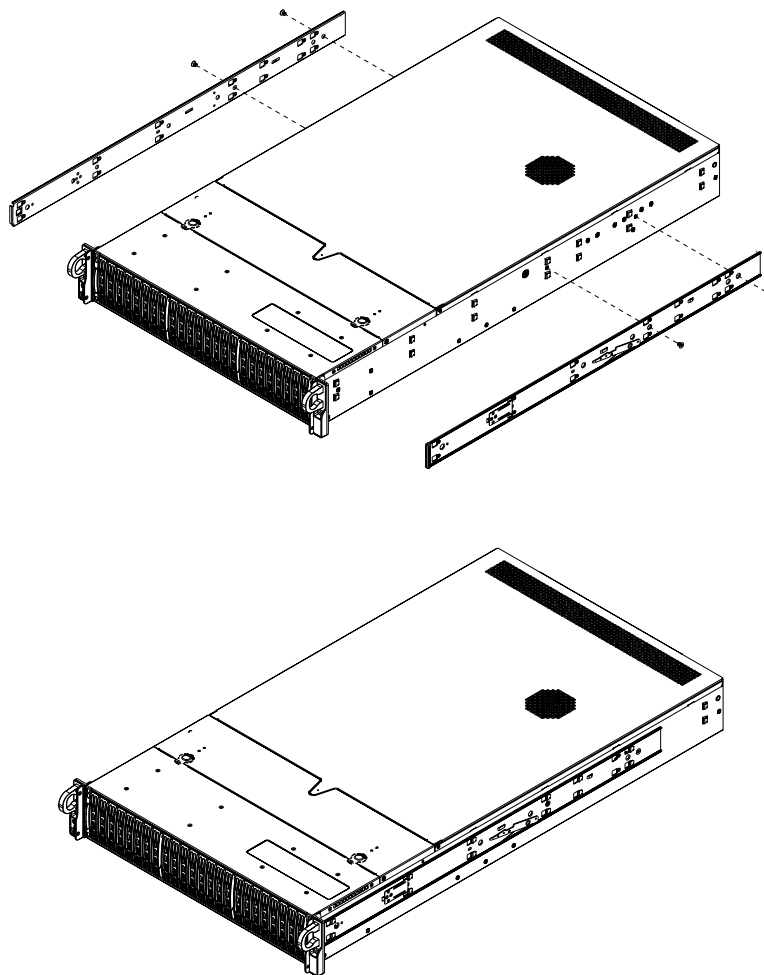

Figure 2-1. Attaching the Inner Rack Rails

Installing the Outer Rails onto the Rack

Installing the Outer Rails

1. Press upward on the locking tab at the rear end of the middle rail.
2. Push the middle rail back into the outer rail.
3. Hang the hooks on the front of the outer rail onto the square holes on the front of the rack. If desired, use screws to secure the outer rails to the rack.
4. Pull out the rear of the outer rail, adjusting the length until it just fits within the posts of the rack.
5. Hang the hooks of the rear section of the outer rail onto the square holes on the rear of the rack. Take care that the proper holes are used so the rails are level. If desired, use screws to secure the rear of the outer rail to the rear of the rack.
6. Repeat for the other outer rail.

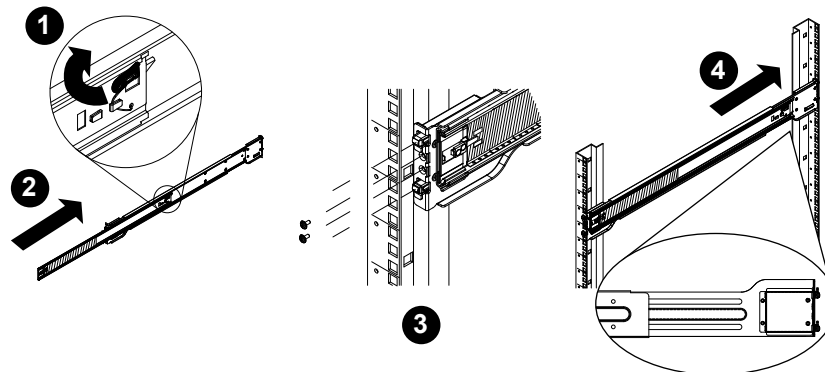

Figure 2-2. Installing the Outer Rails to the Rack

Note: The figure above is for illustrative purposes only. Always install servers at the bottom of the rack first.



Stability hazard. The rack stabilizing mechanism must be in place, or the rack must be bolted to the floor before you slide the unit out for servicing. Failure to stabilize the rack can cause the rack to tip over.

2.5 Installing the Chassis into a Rack

Once rails are attached to the chassis and the rack, you can install the server.

Installing the Chassis into a Rack

1. Extend the outer rails as illustrated above.
2. Align the inner rails of the chassis with the outer rails on the rack.
3. Slide the inner rails into the outer rails, keeping the pressure even on both sides. When the chassis has been pushed completely into the rack, it should click into the locked position.
4. Optional screws may be used to hold the front of the chassis to the rack.

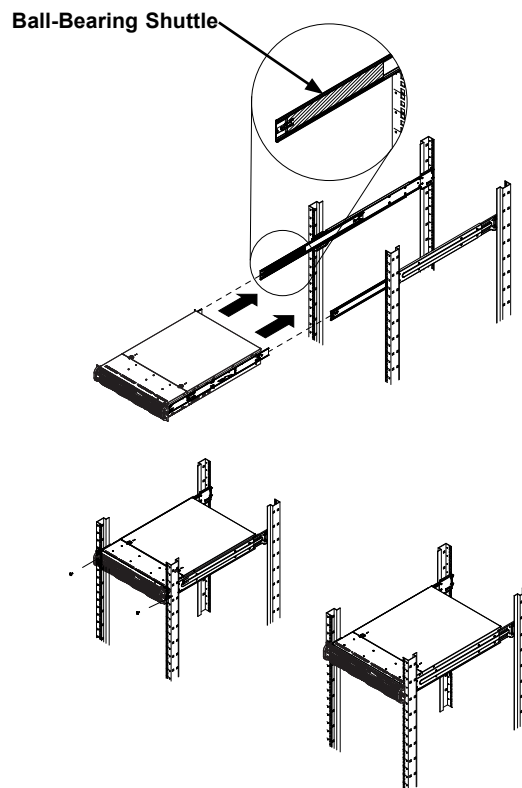

Figure 2-3. Installing the Server into the Rack

Notes: Figure is for illustrative purposes only. Always install servers to the bottom of a rack first.

Removing the Chassis from the Rack

Caution! It is dangerous for a single person to off-load the heavy chassis from the rack without assistance. Be sure to have sufficient assistance supporting the chassis when removing it from the rack. Use a lift.

1. If necessary, loosen the thumb screws on the front of the chassis that hold it in the rack.
2. Pull the chassis forward out the front of the rack until it stops.
3. Press the release latches on each of the inner rails downward simultaneously and continue to pull the chassis forward and out of the rack.

Chapter 3

Maintenance and Component Installation

This chapter provides instructions on installing and replacing main system components. To prevent compatibility issues, only use components that match the specifications and/or part numbers given.

Installation or replacement of most components require that power first be removed from the system. Please follow the procedures given in each section.

3.1 Powering Down the System

Use the following procedure to ensure that power has been removed from the system. This step is necessary when removing or installing non hot-swap components.

1. Use the operating system to power down the system.
2. After the system has completely shut down, disconnect the AC power cord(s) from the power strip or outlet and remove the AC power cords from all power supply modules.
3. Disconnect the power cord(s) from the power supply module(s).
4. When performing service on non hot-swap components, remove the system from the rack and place it on a bench or desk. Do not service with the system extended from the rack.

3.2 Accessing the System

The CSE-218HTS chassis features a removable top cover, which allows easy access to the inside of the chassis.

Removing the Top Cover

1. Press the two release buttons and slide the cover toward the rear.
2. Lift the top cover up.

Check that all ventilation openings on the top cover and the top of the chassis are clear and unobstructed.

Caution: Except for short periods of time, do not operate the server without the cover in place. The chassis cover must be in place to allow for proper airflow and to prevent overheating.

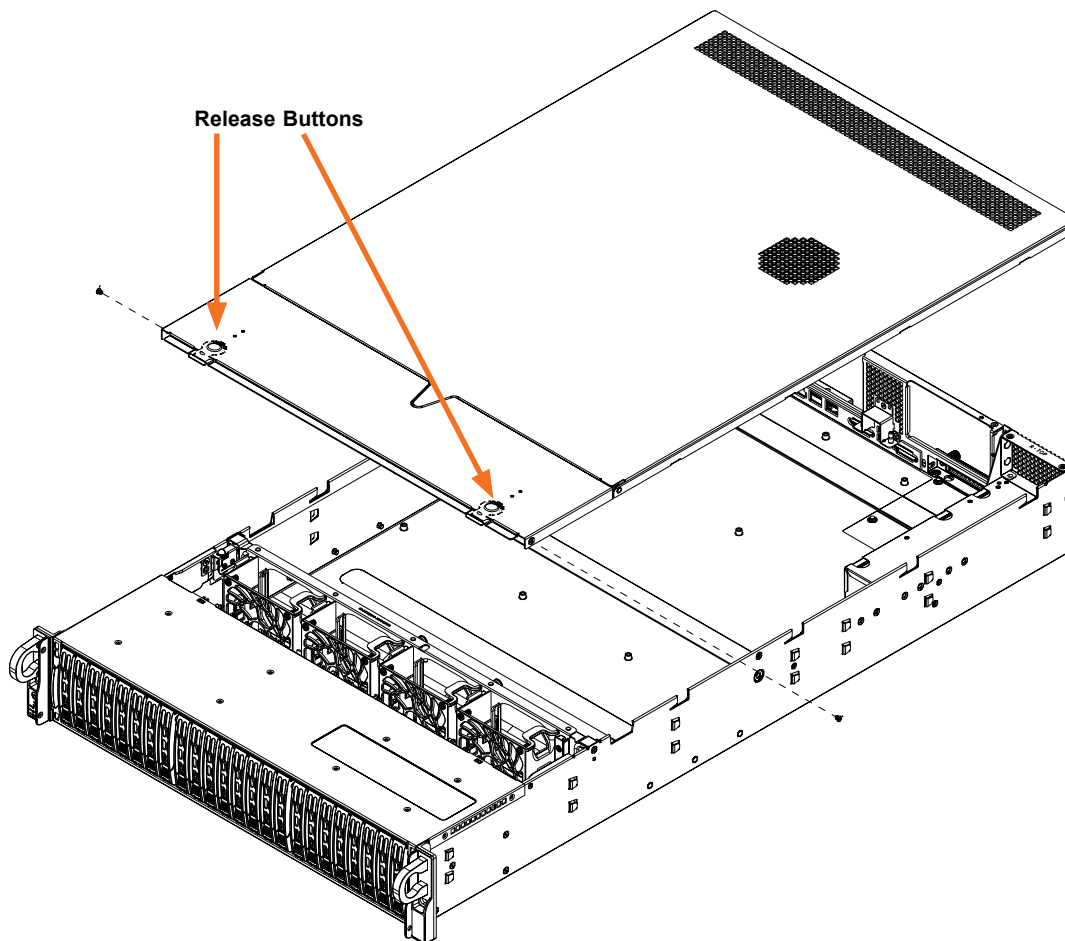

Figure 3-1. Removing the Chassis Cover

3.3 Static-Sensitive Devices

Electrostatic Discharge (ESD) can damage electronic components. To avoid damaging your motherboard, it is important to handle it very carefully. The following measures are generally sufficient to protect the system PCBs from ESD.

Precautions

- Use a grounded wrist strap designed to prevent static discharge.
- Touch a grounded metal object before removing any PCB (printed circuit board) from its antistatic bag.
- Handle PCBs by their edges only; do not touch its components, peripheral chips, memory modules or gold contacts.
- When handling chips or modules, avoid touching their pins.
- Put the PCBs back into their antistatic bags when not in use.
- Use only the correct type of onboard CMOS battery. Do not install the onboard battery upside down to avoid possible explosion.

3.4 Processor and Heatsink Installation

The processor (CPU) must first be attached to the processor carrier to form the processor carrier assembly. This assembly gets attached to the heatsink to form the processor heatsink module (PHM), which is then installed into the CPU socket. Before installing, be sure to perform the steps below:

- Please carefully follow the instructions given on ESD precautions.
- After shutting down the system, unplug the AC power cords from all power supplies.
- Check that the plastic protective cover is on the CPU socket and that none of the socket pins are bent. If they are, contact your retailer.
- When handling the processor, avoid touching or placing direct pressure on the LGA lands (gold contacts). Improper installation or socket misalignment can cause serious damage to the processor or the socket, and may require manufacturer repairs.
- Thermal grease is pre-applied on new heatsinks. No additional thermal grease is needed.
- Refer to the Supermicro website for updates on processor and memory support.
- All graphics in this manual are for illustration only. Your components may look different.

The Processor Carrier Assembly

The processor carrier assembly is comprised of the processor and the processor carrier.

To create the processor carrier assembly, please follow the steps below:

Note: Before installation, be sure to review the Static-Sensitive Devices section earlier in this chapter.

1. Hold the processor with the gold pins (LGA lands) facing down. Locate the gold triangle at the corner of the processor and the corresponding hollowed triangle on the processor carrier as shown below. These triangles indicate the location of pin 1.
2. Turn the processor over (with the gold pins up). Locate the CPU keys on the processor and the four latches on the carrier as shown below.

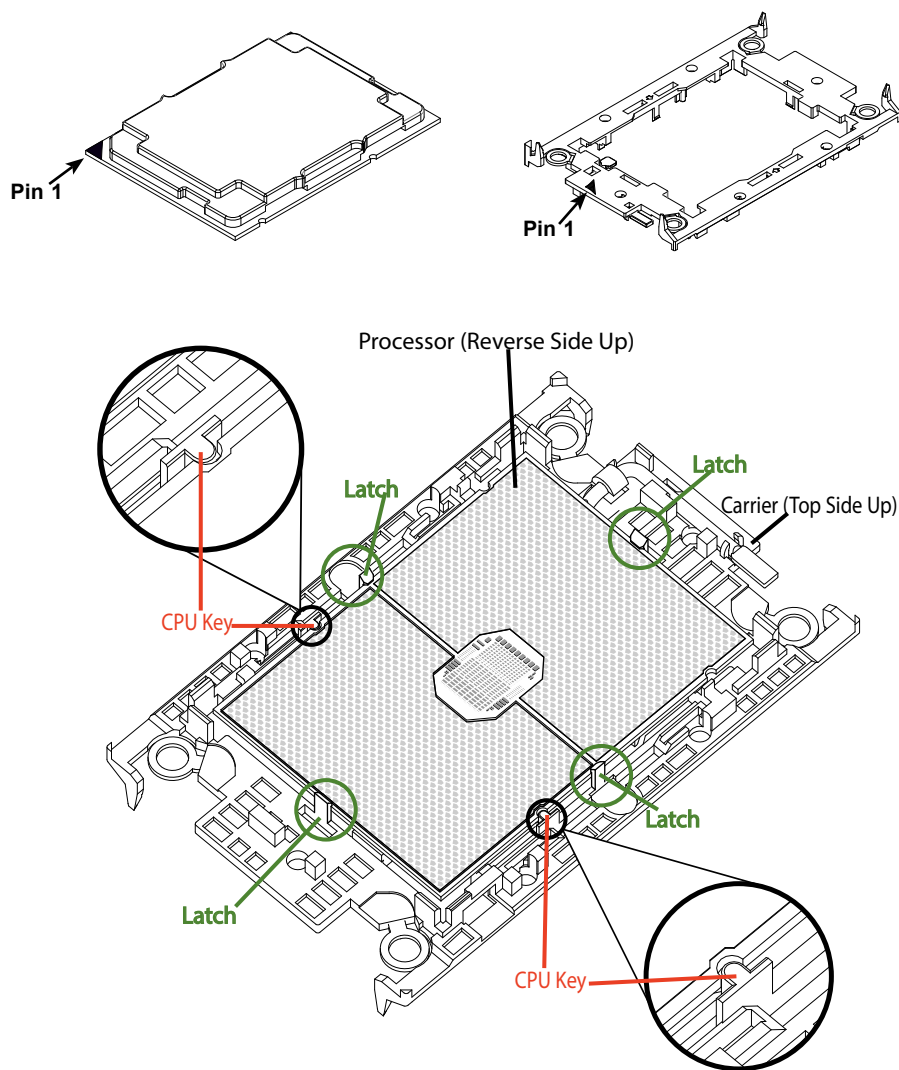

(with Processor Seated inside the Carrier)

3. Locate the lever on the carrier and press it down as shown below.

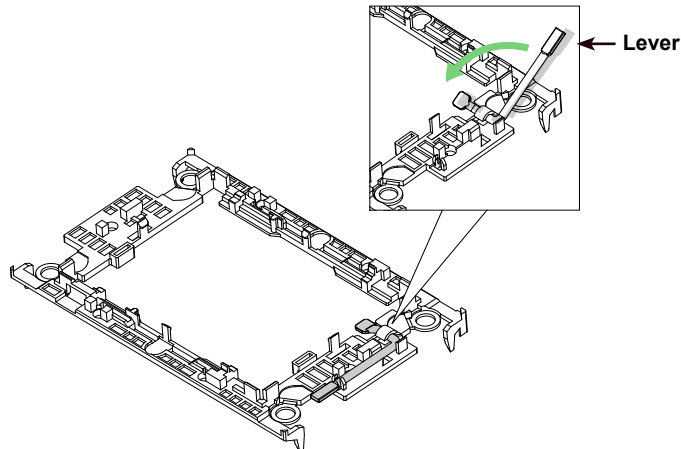

4. Using pin 1 as a guide, carefully align the CPU keys on the processor (A & B) with those on the carrier (a & b) as shown below.

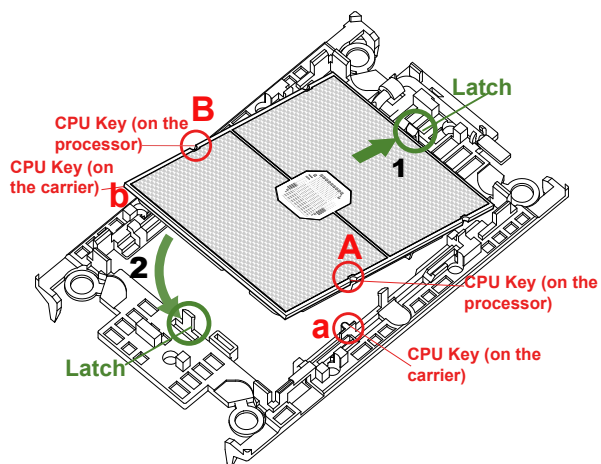

5. Once aligned, carefully place one end of the processor under latch 1 on the carrier, and then press the other end down until it snaps into latch 2.
6. After the processor is placed inside the carrier, examine the four sides of the processor, making sure that the processor is properly seated on the carrier.

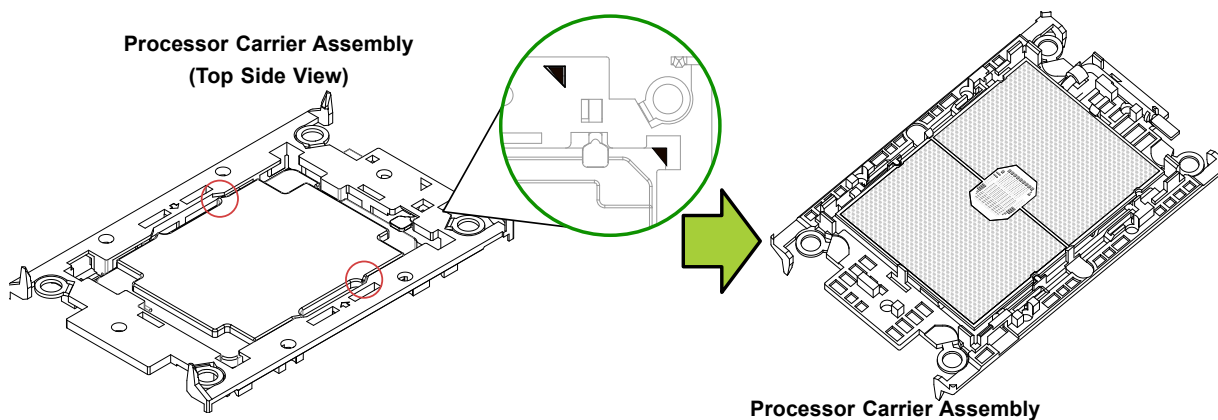

The Processor Heatsink Module (PHM)

After creating the processor carrier assembly, follow the instructions below to mount the heatsink onto the carrier assembly to form the processor heatsink module (PHM).

Note: If this is a new heatsink, the thermal grease has been pre-applied. Otherwise, apply the proper amount of thermal grease to the underside of the heatsink.

1. Turn the heatsink over with the thermal grease facing up. Pay attention to the two triangle cutouts (A, B) located at the diagonal corners of the heatsink as shown in the drawing below.
2. Hold the processor carrier assembly upside-down to locate the triangles on the processor and the carrier, which indicate pin 1.
3. Turn the processor carrier assembly over so that the gold pins are facing up. Locate the two pin 1 locations ("A" on the processor and "a" on the processor carrier assembly).
4. Align "a" on the processor carrier assembly with the triangular cutout "A" on the heatsink along with "b", "c", "d" on the processor assembly with "B", "C", "D" on the heatsink.
5. Once properly aligned, place the heatsink on the processor carrier assembly with all corners matched up, making sure that the four clips are properly securing the heatsink.

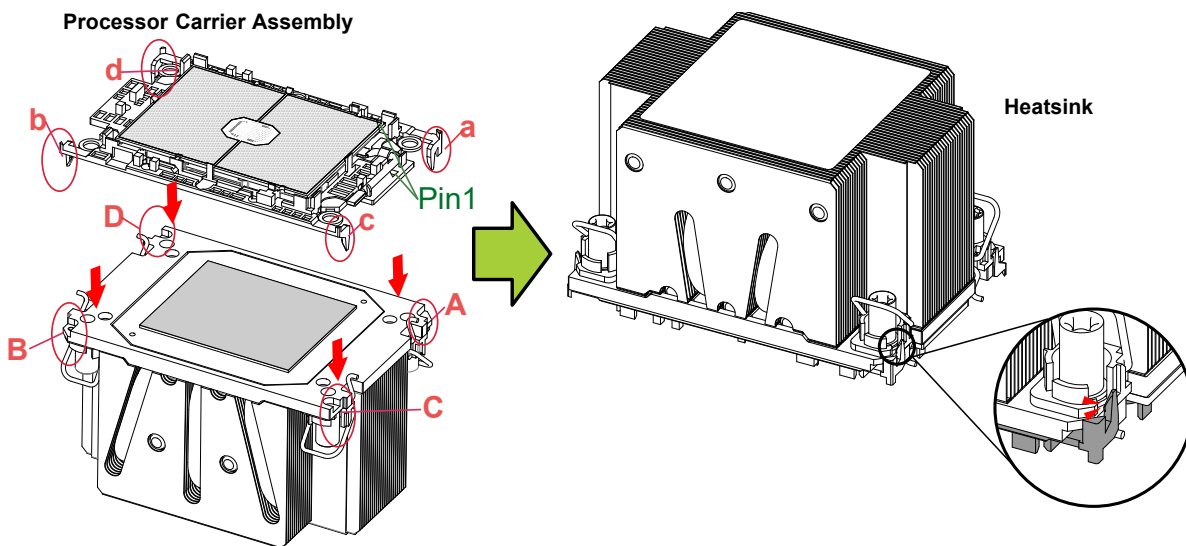

Preparing the CPU Socket for Installation

The CPU socket comes with a plastic protective cover, which needs to be removed before installing the Processor Heatsink Module (PHM). Do this by gently squeezing the grip tabs then pulling the cover off.

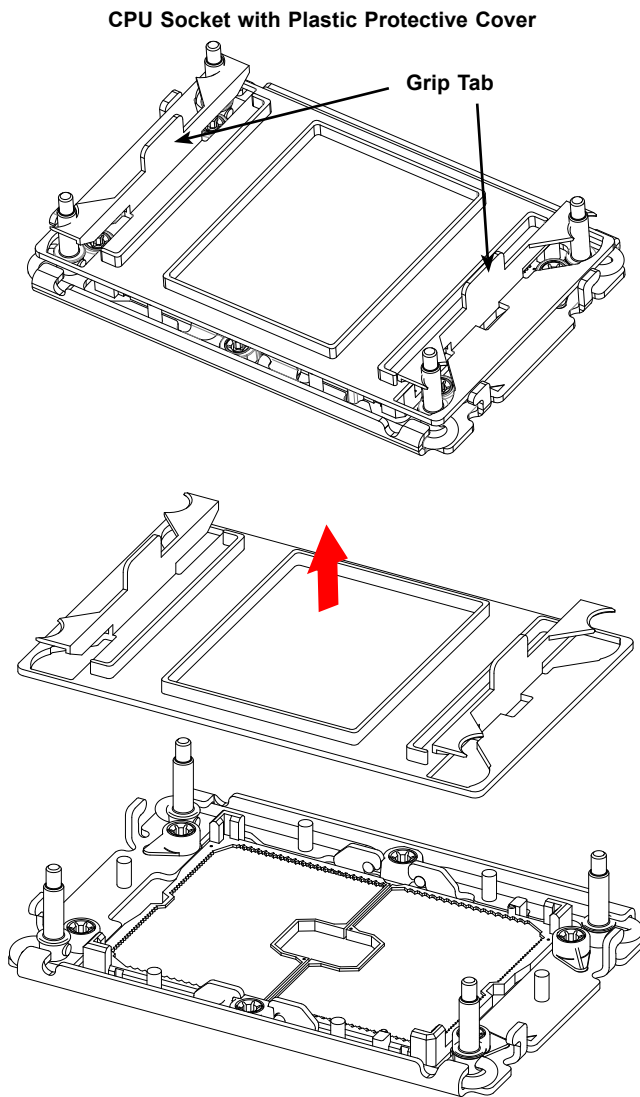

Installing the PHM into the CPU Socket

After assembling the Processor Heatsink Module (PHM), you are ready to install it into the CPU socket.

1. Locate four threaded fasteners (a, b, c, d) on the CPU socket.

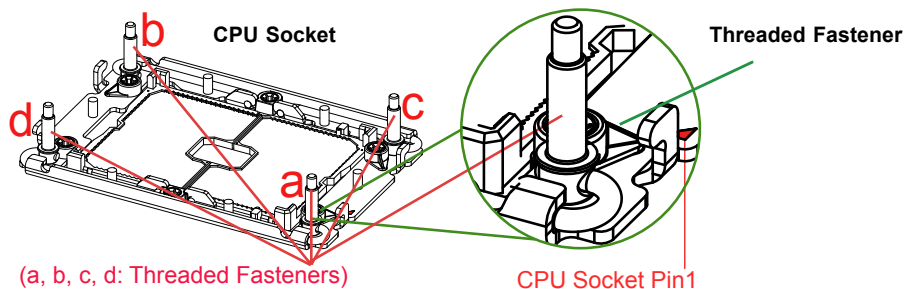

2. Locate four peek nuts (A, B, C, D) and four rotating wires (1, 2, 3, 4) on the heatsink as shown below.

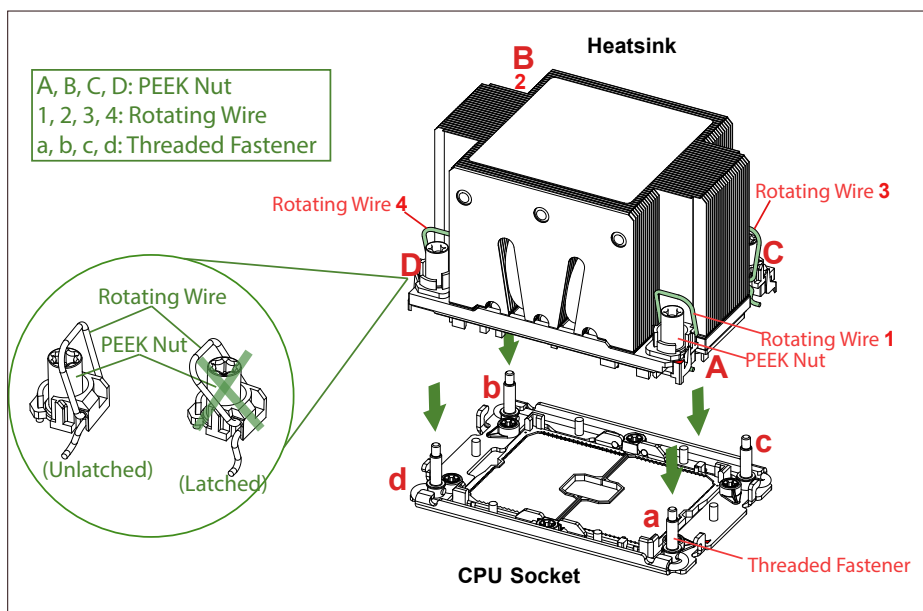

3. Check the rotating wires (1, 2, 3, 4) to make sure that they are in the unlatched position as shown.

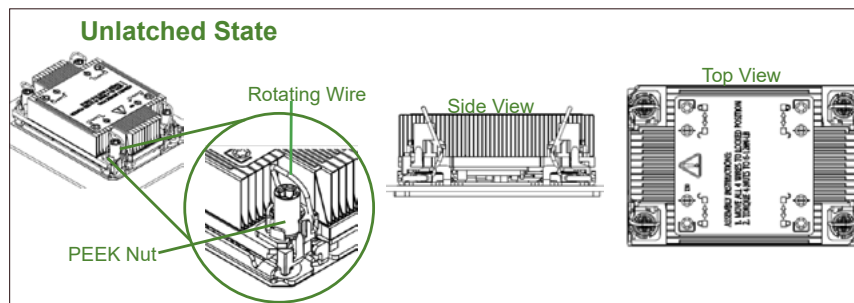

4. Align peek nut "A" (next to the triangular pin 1 on the heatsink) with threaded fastener "a" on the CPU socket. Then align peek nuts "B", "C", "D" on the heatsink with threaded fasteners "b", "c", "d" on the CPU socket, making sure that all peek nuts and threaded fasteners are properly aligned.
5. Once aligned, gently place the heatsink on the CPU socket, making sure that each peek nut is properly attached to its corresponding threaded fastener.

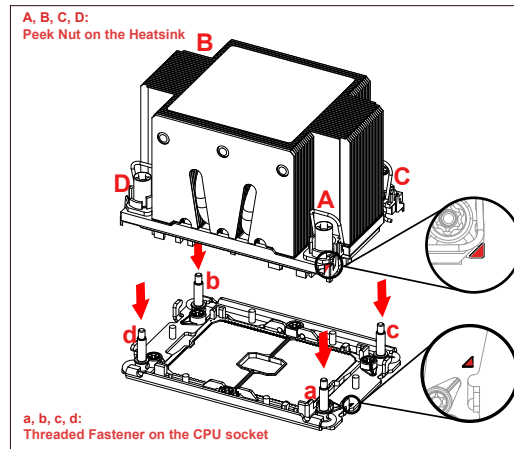

6. Press all four rotating wires outward and make sure that the heatsink is securely latched into the CPU socket.

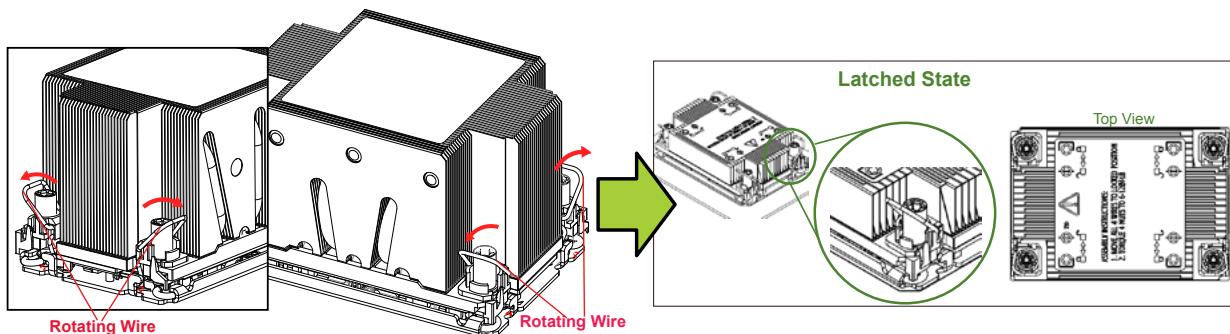

7. With a t30-bit screwdriver, tighten all peek nuts in the sequence of "A", "B", "C", and "D" with even pressure. To avoid damaging the processor or socket, do not use a force greater than 12 lbf-in when tightening the screws.
8. Examine all corners of the heatsink to ensure that the PHM is firmly attached to the CPU socket.

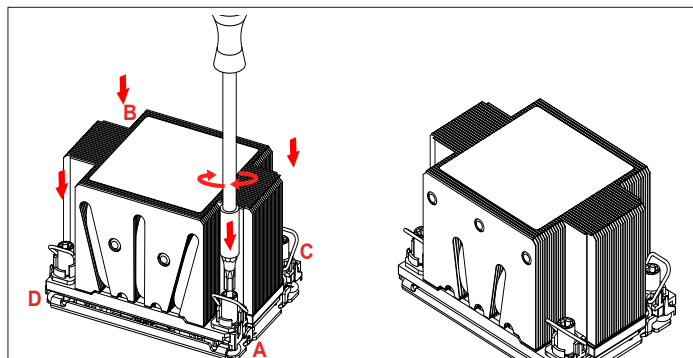

Removing the PHM from the CPU Socket

Before removing the PHM from the motherboard, first shut down the system and unplug the AC power cord from all power supplies.

1. Use a t30-bit screwdriver to loosen the four peek nuts on the heatsink in the sequence of A, B, C, and D.

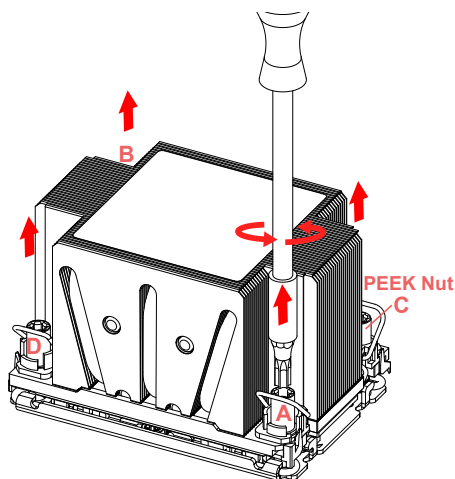

2. Once the peek nuts have been loosened from the CPU socket, press the rotating wires inward to unlatch the PHM from the socket as shown below.

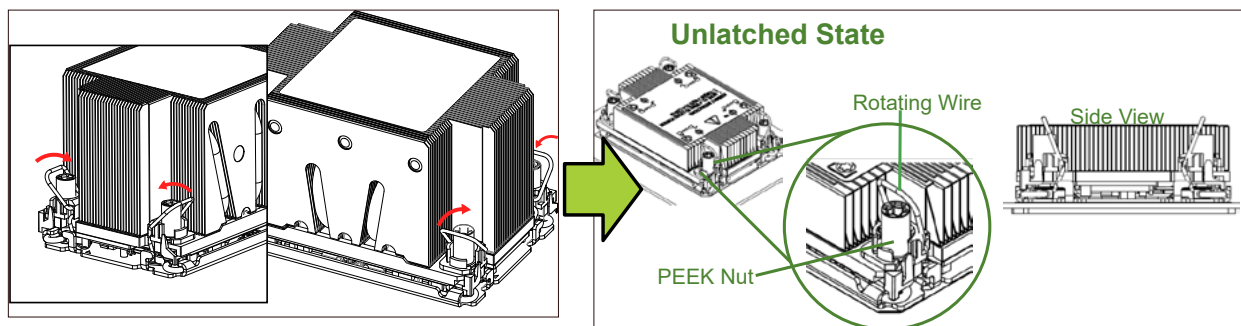

3. Gently lift the PHM upward to remove it from the CPU socket.

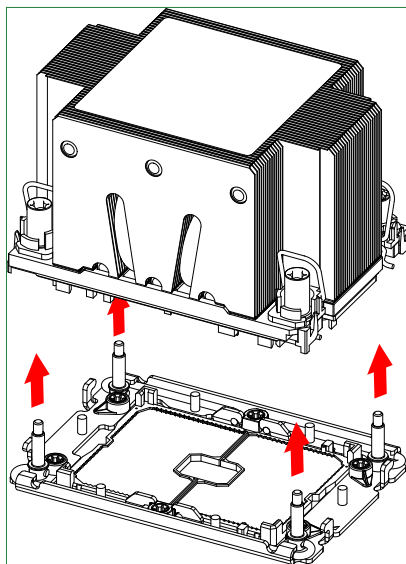

Removing the Processor Carrier Assembly from the PHM

To remove the processor carrier assembly from the PHM, please follow the steps below:

1. Detach the four plastic clips (marked a, b, c, d) on the processor carrier assembly from the four corners of the heatsink (marked A, B, C, D) as shown below.

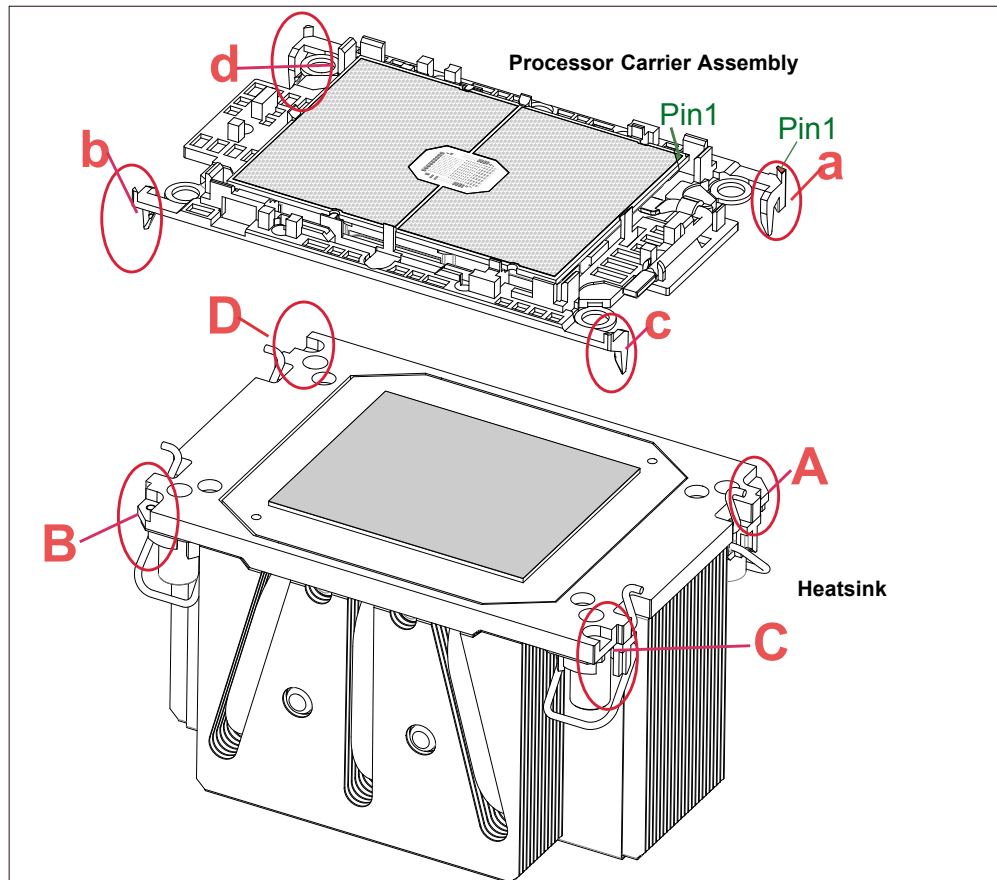

2. When all plastic clips have been detached from the heatsink, remove the processor carrier assembly from the heatsink

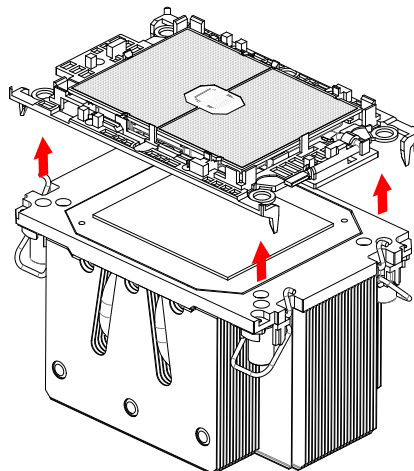

Removing the Processor from the Processor Carrier Assembly

Once you have removed the processor carrier assembly from the PHM, you are ready to remove the processor from the processor carrier by following the steps below.

1. Unlock the lever from its locked position and push it upwards to disengage the processor from the processor carrier as shown below right.

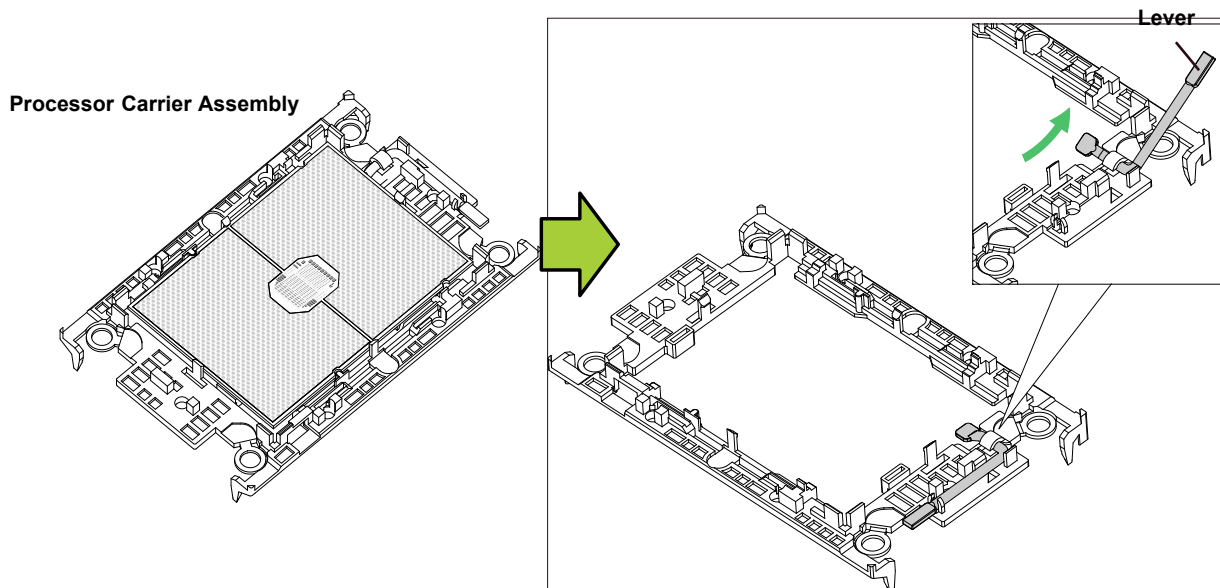

2. Once the processor has been loosened from the carrier, carefully remove the processor from the carrier.

Note: Please handle the processor with care to avoid damaging it or its pins.

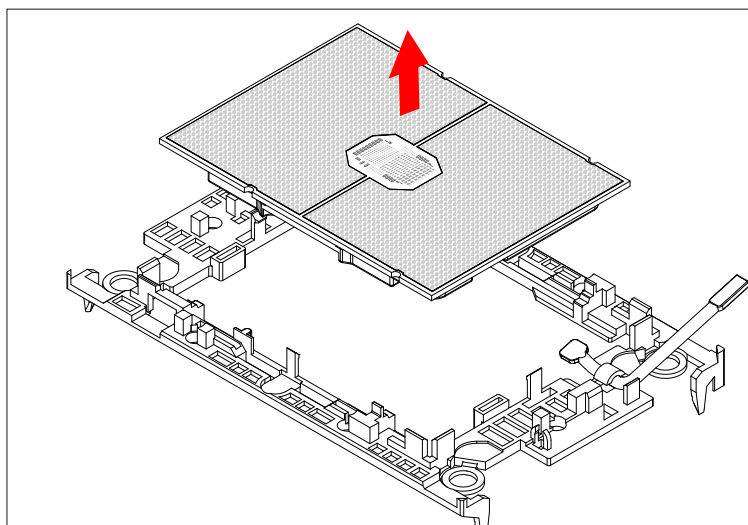

3.5 Memory

Memory Support

The X12QCH+-P has 48 DIMM slots to support up to 12TB 3DS ECC DDR4-3200:RDIMM/LRDIMM or 18TB Intel® Optane™ DDR4-2666:DCPMM, RDIMM/LRDIMM//DCPMM. For validated memory, use our [Product Resources page](#). Check the Supermicro website for possible updates to memory support.

Memory Installation Sequence

Memory for this motherboard is populated using the "Fill First" method. The DIMM slots with blue release tabs are considered the first DIMM of their channel and those with white release tabs are the second of the channel. When installing memory modules, be sure to populate the memory slots with the blue release tabs first and then populate the those with the white release tabs.

General Memory Population Requirements

1. Be sure to use the memory modules of the same type and speed on the motherboard. Mixing of memory modules of different types and speeds is not allowed.
2. Using unbalanced memory topology such as populating two DIMMs in one channel while populating one DIMM in another channel will result in reduced memory performance.
3. Populating memory slots with a pair of DIMM modules of the same type and size will result in interleaved memory, which will improve memory performance.

DDR4 Memory Support					
Type	Ranks Per DIMM & Data Width	DIMM Capacity (GB)		Speed (MT/s); Voltage (V); Slots Per Channel (SPC) and DIMMs Per Channel (DPC)	
				1DPC (1-DIMM Per Channel)	2DPC (2-DIMM Per Channel)
		8Gb	16Gb	1.2 V	1.2 V
RDIMM	SRx8	8GB	16GB	3200	3200
	SRx4	16GB	32GB		
	DRx8	16GB	32GB		
	DRx4	32GB	64GB		
RDIMM-3Ds	(4R/8R) x4	2H-64GB 4H-128GB	2H-128GB 4H-256GB		
LRDIMM	QRx4	64GB	128GB	3200	3200
LRDIMM-3Ds	(4R/8R) x4	4H-128GB	2H-128GB 4H-256GB	3200	3200

DDR4 Memory Population Table

Note: Unbalanced memory configurations decrease memory performance and is not recommended on Supermicro motherboards.

Memory Population Sequence for Half Memory Configuration

Memory Population Sequence: Half Memory Configuration (4 CPUs & 24 DIMMs Installed)	
4 CPUs & 24 DIMMs (6 DIMMs per CPU)	Memory Population Sequence
CPU1 + 6 DIMMs	CPU1: P1-DIMMC1/P1-DIMMB1/P1-DIMMA1/P1-DIMMD1/P1-DIMME1/P1-DIMMF1
CPU2 + 6 DIMMs	CPU2: P2-DIMMC1/P2-DIMMB1/P2-DIMMA1/P2-DIMMD1/P2-DIMME1/P2-DIMMF1
CPU3 + 6 DIMMs	CPU3: P3-DIMMC1/P3-DIMMB1/P3-DIMMA1/P3-DIMMD1/P3-DIMME1/P3-DIMMF1
CPU4 + 6 DIMMs	CPU4: P4-DIMMC1/P4-DIMMB1/P4-DIMMA1/P4-DIMMD1/P4-DIMME1/P4-DIMMF1

Memory Population Table with Full Memory Configuration

Memory Population Sequence: Full Memory Configuration (4 CPUs & 48 DIMMs Installed)	
4 CPUs & 48 DIMMs (12 DIMMs per CPU)	Memory Population Sequence
CPU1 + 12 DIMMs	CPU1: P1-DIMMC1/P1-DIMMC2/P1-DIMMB1/P1-DIMMB2/P1-DIMMA1/P1-DIMMA2/ P1-DIMMD2/P1-DIMMD1/P1-DIMME2/P1-DIMME1/P1-DIMMF2/P1-DIMMF1
CPU2 + 12 DIMMs	CPU2: P2-DIMMC1/P2-DIMMC2/P2-DIMMB1/P2-DIMMB2/P2-DIMMA1/P2-DIMMA2/ P2-DIMMD2/P2-DIMMD1/P2-DIMME2/P2-DIMME1/P2-DIMMF2/P2-DIMMF1
CPU3 + 12 DIMMs	CPU3: P3-DIMMC1/P3-DIMMC2/P3-DIMMB1/P3-DIMMB2/P3-DIMMA1/P3-DIMMA2/ P3-DIMMD2/P3-DIMMD1/P3-DIMME2/P3-DIMME1/P3-DIMMF2/P3-DIMMF1
CPU4 + 12 DIMMs	CPU4: P4-DIMMC1/P4-DIMMC2/P4-DIMMB1/P4-DIMMB2/P4-DIMMA1/P4-DIMMA2/ P4-DIMMD2/P4-DIMMD1/P4-DIMME2/P4-DIMME1/P4-DIMMF2/P4-DIMMF1

Intel® Optane™ PMem 200 Series Memory Population (Full Configuration)

Note: Optane memory is supported by 3rd Generation Intel® Xeon® Scalable processors (83xxH/63xxH/53xxH Series) only.

Symmetric Population												
2-2-2	(For Channel Configuration: 2-2-2)											
Modes												
CPU1	P1-DIMMF1	P1-DIMMF2	P1-DIMME1	P1-DIMME2	P1-DIMMD1	P1-DIMMD2	P1-DIMMA2	P1-DIMMA1	P1-DIMMB2	P1-DIMMB1	P1-DIMMC2	P1-DIMMC1
AD	DRAM1	<i>PMem</i>	DRAM1	<i>PMem</i>	DRAM1	<i>PMem</i>	<i>PMem</i>	DRAM1	<i>PMem</i>	DRAM1	<i>PMem</i>	DRAM1
CPU2	P2-DIMMF1	P2-DIMMF2	P2-DIMME1	P2-DIMME2	P2-DIMMD1	P2-DIMMD2	P2-DIMMA2	P2-DIMMA1	P2-DIMMB2	P2-DIMMB1	P2-DIMMC2	P2-DIMMC1
AD	DRAM1	<i>PMem</i>	DRAM1	<i>PMem</i>	DRAM1	<i>PMem</i>	<i>PMem</i>	DRAM1	<i>PMem</i>	DRAM1	<i>PMem</i>	DRAM1
CPU3	P3-DIMMF1	P3-DIMMF2	P3-DIMME1	P3-DIMME2	P3-DIMMD1	P3-DIMMD2	P3-DIMMA2	P3-DIMMA1	P3-DIMMB2	P3-DIMMB1	P3-DIMMC2	P3-DIMMC1
AD	DRAM1	<i>PMem</i>	DRAM1	<i>PMem</i>	DRAM1	<i>PMem</i>	<i>PMem</i>	DRAM1	<i>PMem</i>	DRAM1	<i>PMem</i>	DRAM1
CPU4	P4-DIMMF1	P4-DIMMF2	P4-DIMME1	P4-DIMME2	P4-DIMMD1	P4-DIMMD2	P4-DIMMA2	P4-DIMMA1	P4-DIMMB2	P4-DIMMB1	P4-DIMMC2	P4-DIMMC1
AD	DRAM1	<i>PMem</i>	DRAM1	<i>PMem</i>	DRAM1	<i>PMem</i>	<i>PMem</i>	DRAM1	<i>PMem</i>	DRAM1	<i>PMem</i>	DRAM1

Memory Population Sequence: Half Memory Configuration (4 CPUs & 16 DIMMs Installed)	
4 CPUs & 16 DIMMs (4 DIMMs per CPU)	Memory Population Sequence
CPU1 + 4 DIMMs	CPU1: P1-DIMMB1/P1-DIMMA1/P1-DIMMD1/P1-DIMME1
CPU2 + 4 DIMMs	CPU2: P2-DIMMB1/P2-DIMMA1/P2-DIMMD1/P2-DIMME1
CPU3 + 4 DIMMs	CPU3: P3-DIMMB1/P3-DIMMA1/P3-DIMMD1/P3-DIMME1
CPU4 + 4 DIMMs	CPU4: P4-DIMMB1/P4-DIMMA1/P4-DIMMD1/P4-DIMME1

DIMM Population Order per CPU												
CPU1	C1	C2	B1	B2	A1	A2	D2	D1	E2	E1	F2	F1
1 DIMM					X							
2 DIMMs*					X			X				
3 DIMMs*	X		X		X							
4 DIMMs			X		X			X		X		
5 DIMMs*	X		X		X			X		X		
6 DIMMs	X		X		X			X		X		X
7 DIMMs*			X	X	X	X		X		X		X
8 DIMMs*			X	X	X	X	X	X	X	X		
9 DIMMs*	X	X	X	X	X	X		X		X		X
10 DIMMs*	X		X	X	X	X	X	X	X	X		X
11 DIMMs*	X	X	X	X	X	X	X	X	X	X		X
12 DIMMs	X	X	X	X	X	X	X	X	X	X	X	X

*Unbalanced configuration (reduces performance and is not recommended).

“Incorrect Memory DIMM Population” message will appear during POST.

- BIOS/OS will only show the total of the workable memory size, which may not total up to the amount that is physically in the system.

DIMM Installation

1. Insert the desired number of DIMMs into the slots based on the recommended DIMM population tables shown above.
2. Push the release tabs on both ends of the DIMM slot outwards to unlock it.

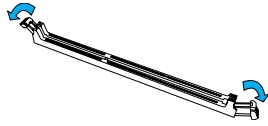

3. Align the key of the DIMM module with the receptive point on the memory slot.

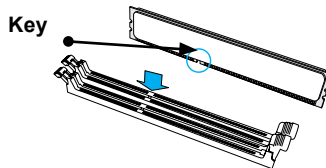

4. Align the notches on both ends of the module with the receptive points on the ends of the slot.

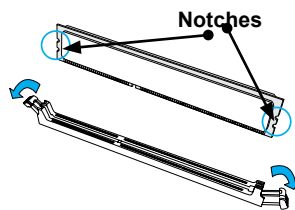

5. Push both ends of the module straight down into the slot until the module snaps into place.

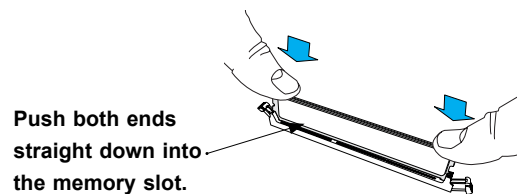

6. Press the release tabs to the lock positions to secure the DIMM module into the slot.

DIMM Removal

Press both release tabs on the ends of the DIMM module to unlock it. Once the DIMM module is loose, remove it from the memory slot.

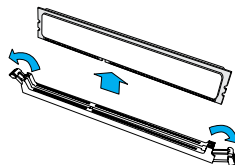

Warning! To avoid causing any damage to the DIMM module or the DIMM socket, do not use excessive force when pressing the release tabs on the ends of the DIMM socket. Handle DIMMs with care. Be aware and follow the ESD instructions given at the beginning of this chapter.

3.6 Motherboard Battery

The motherboard uses non-volatile memory to retain system information when system power is removed. This memory is powered by a lithium battery residing on the motherboard.

Replacing the Battery

Begin by [removing power](#) from the system.

1. Push aside the small clamp that covers the edge of the battery. When the battery is released, lift it out of the holder.
2. To insert a new battery, slide one edge under the lip of the holder with the positive (+) side facing up. Then push the other side down until the clamp snaps over it.

Note: Handle used batteries carefully. Do not damage the battery in any way; a damaged battery may release hazardous materials into the environment. Do not discard a used battery in the garbage or a public landfill. Please comply with the regulations set up by your local hazardous waste management agency to dispose of your used battery properly.

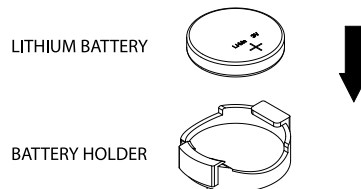

Figure 3-2. Installing the Onboard Battery

Warning: There is a danger of explosion if the onboard battery is installed upside down (which reverses its polarities). This battery must be replaced only with the same or an equivalent type recommended by the manufacturer (CR2032).

3.7 Storage Drives

The system supports 24 hot-swap 2.5" NVMe/SAS3/SATA3 drive bays. Four optional rear 2.5" SAS/SATA drive bays and two M.2 SATA3 slots are also supported. For compatible storage drives, see the [motherboard page](#).

The drives are mounted in toolless drive carriers that simplify their removal from the chassis. These carriers also help promote proper airflow.

Note: Enterprise level hard disk drives are recommended for use in Supermicro chassis and servers. For information on recommended HDDs, visit the Supermicro website product pages at <https://www.supermicro.com/products/nfo/Ultra.cfm>.

Checking the Temperature of an NVMe Drive

There are two ways to check using BMC.

Checking a Drive

- **BMC > Server Health > NVMe SSD** – Shows the temperatures of all NVMe drives.
- **BMC > Server Health > Sensor Reading > NVME_SSD** – Shows the single highest temperature among all the NVMe drives.

Installing Drives

The front of the system has 24 hard drive bays that support NVMe, SAS3 and SATA3 hard drives.



Figure 3-3. Logical Drive Numbers

Removing a Hot-Swap Drive Carrier from the Chassis

1. Press the release button on the drive carrier, which will extend the drive carrier handle.
2. Use the drive carrier handle to pull the drive out of the chassis.

Installing a Hard Drive into a Drive Carrier

1. Insert a drive into the carrier with the PCB side facing down and the connector end toward the rear of the carrier.
2. Align the drive in the carrier so that the screw holes of both line up. Note that there are holes in the carrier marked “SATA” to aid in correct installation.
3. Secure the drive to the carrier with four screws.
4. Insert the drive carrier into its bay, keeping the carrier oriented so that the hard drive is on the top of the carrier and the release button is on the right side. When the carrier reaches the rear of the bay, the release handle will retract.
5. Push the handle in until it clicks into its locked position.

Note: Your operating system must have RAID support to enable the hot-plug capability of the hard drives.

Note: Enterprise level hard disk drives are recommended for use in Supermicro chassis and servers.

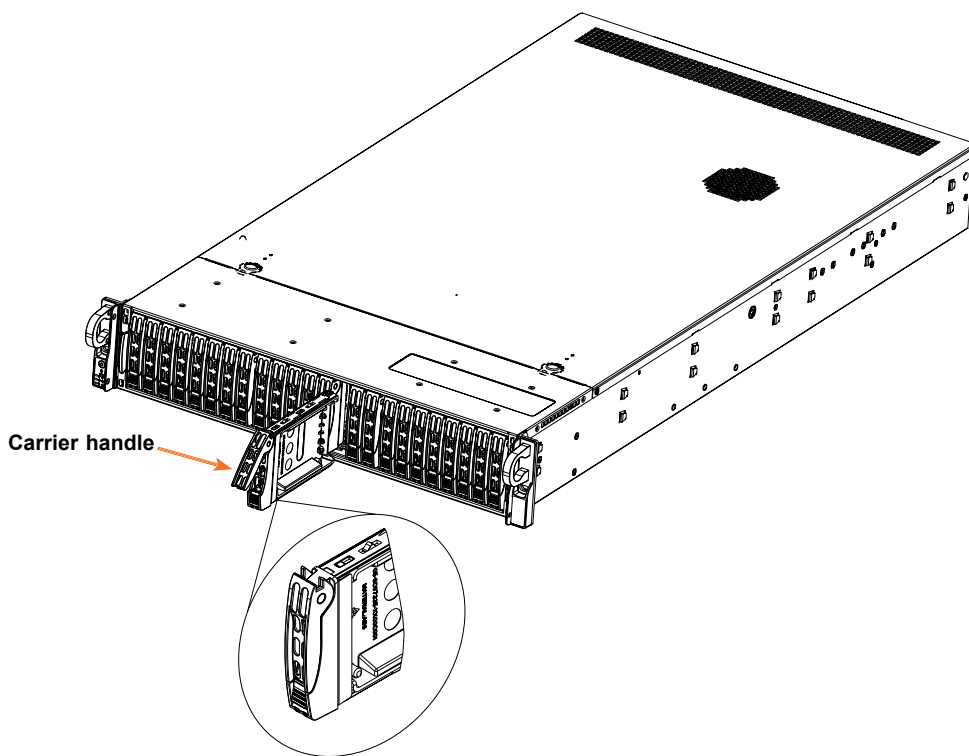

Figure 3-4. Removing a Drive Carrier

Hot-Swap for NVMe Drives

Supermicro servers support NVMe surprise hot-swap. For even better data security, NVMe *orderly* hot-swap is recommended. NVMe drives can be ejected and replaced remotely using BMC.

Note: If you are using VROC, see the VROC appendix in this manual instead.

Ejecting a Drive

1. **BMC > Server Health > NVMe SSD**
2. Select Device, Group and Slot, and click **Eject**. After ejecting, the drive Status LED indicator turns green.
3. Remove the drive.

Note that *Device* and *Group* are categorized by the CPLD design architecture. The SYS-240P-TNRT server has one Device and one Group.

Slot is the slot number on which the NVMe drives are mounted.

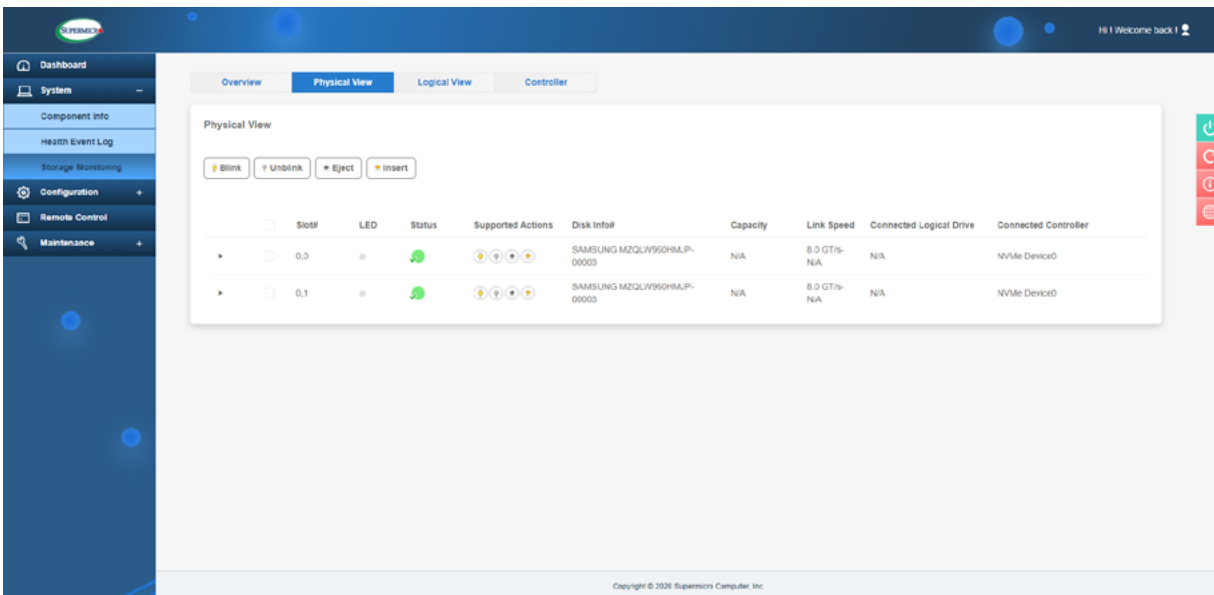

Figure 3-5. BMC Screenshot

Replacing the Drive

1. Insert the replacement drive.
2. **BMC > System > Storage Monitor > Physical View**
3. Select Device, Group and slot and click **Insert**. The drive Status LED indicator flashes red, then turns off. The Activity LED turns blue.

Installing M.2 Solid State Drives

The X12QCH+-P supports M.2 SSDs with a PCIe 3.0 M.2 slot (PCIE M.2) and two M.2-HC S-SATA slots (JMD1/JMD2), which support PCIe 3.0 x4 NVMe/SATA SSDs. These M.2 slots support 2280 and 22110 form factors via SlimSAS x8 cables.

Caution: DO NOT perform this service with the system mounted inside the rack.

Caution: The handles used for pulling the system from the rack are not intended to be used to pick up or lift the system.

Installing M.2 Drives

1. Power down the system as described in Section 3.1.
2. Remove the system from the rack and place it on a bench, then remove the cover as described [previously](#).
3. Begin by removing the riser brackets from the chassis.
4. Insert the M.2 sideways into the connector so that it lays flat, then secure it to the bracket with the plastic clip.
5. Repeat as necessary for more M.2 drives.
6. With the drives installed and secured to the bracket, replace the bracket back into the chassis as before.
7. Finish by replacing the cover and restoring power to the system.

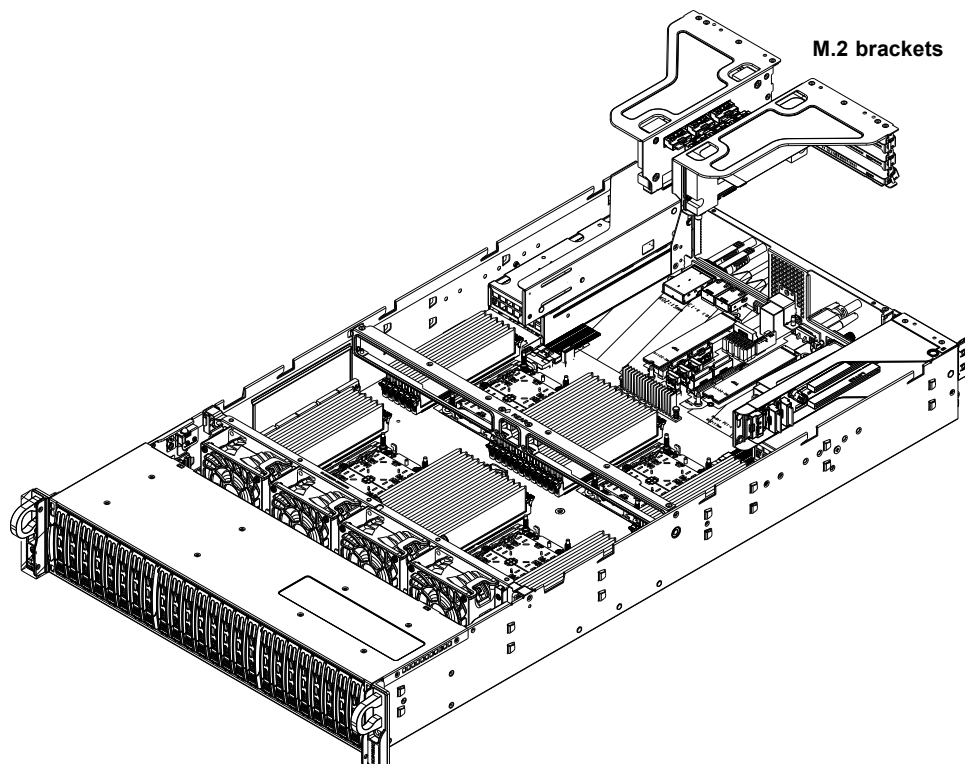

Figure 3-6. Installing an M.2 SSD

3.8 System Cooling

Fans

Four 8-cm heavy duty fans provide the cooling for the system. Fans are hot-swap and can be replaced without powering down the system. The electrical connections are automatically made when a fan is inserted into its slot.

Ensure the chassis cover is only off for a short time and makes a good seal when replaced for the cooling air to circulate properly. Fan speed is controlled by system temperature via BMC. If a fan fails, the remaining fans will ramp up to full speed. Replace any failed fan at your earliest convenience with the same type and model (the system can continue to run with a failed fan).

Changing a System Fan

1. Determine which fan has failed using BMC if possible. If not, remove the chassis cover while the power is on and examine the fans to determine which one has failed.
2. Pull the system partially out from the rack.
3. With the top cover partially pushed back, depress the release buttons on the front section of the top cover to swing it open on its hinges.
4. Squeeze the fan tabs of the failed fan and lift the fan housing up and out of the chassis.
5. To install a fan, push it into the proper location until it clicks.
6. Finish by fully closing the cover and pushing the system back into the rack.

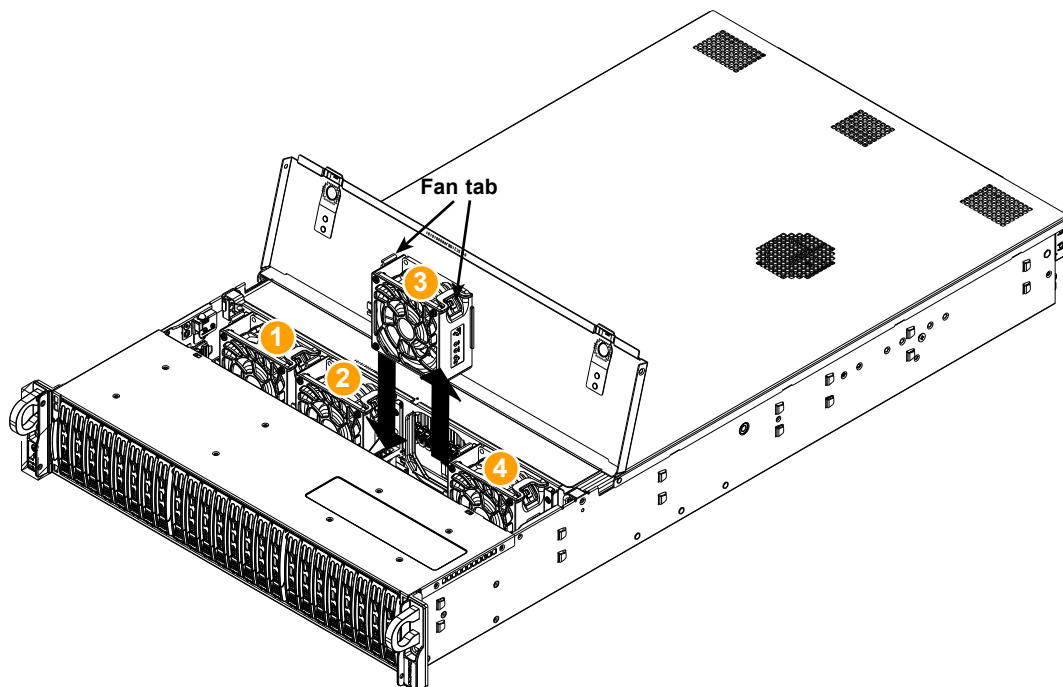

Figure 3-7. Installing a Fan (positions indicated)

Air Shrouds

Air shrouds concentrate airflow to maximize fan efficiency. The SYS-240P-TNRT includes three different sets of air shrouds.

Caution: DO NOT perform this service with the system mounted inside the rack.

Air Shroud for Memory (CPU1/2)

Four 2U air shrouds cool the DIMM slots controlled by CPUs 1 and 2 (see figure below).

1. Power down the system as described in Section 3.1.
2. Remove the system from the rack and place it on a bench, then remove the cover as described [previously](#).
3. Place each air shroud over six DIMM slots at a time for both CPU1 and CPU2-controlled DIMM slots, as illustrated below.
4. Close the cover and push the system back into the rack.

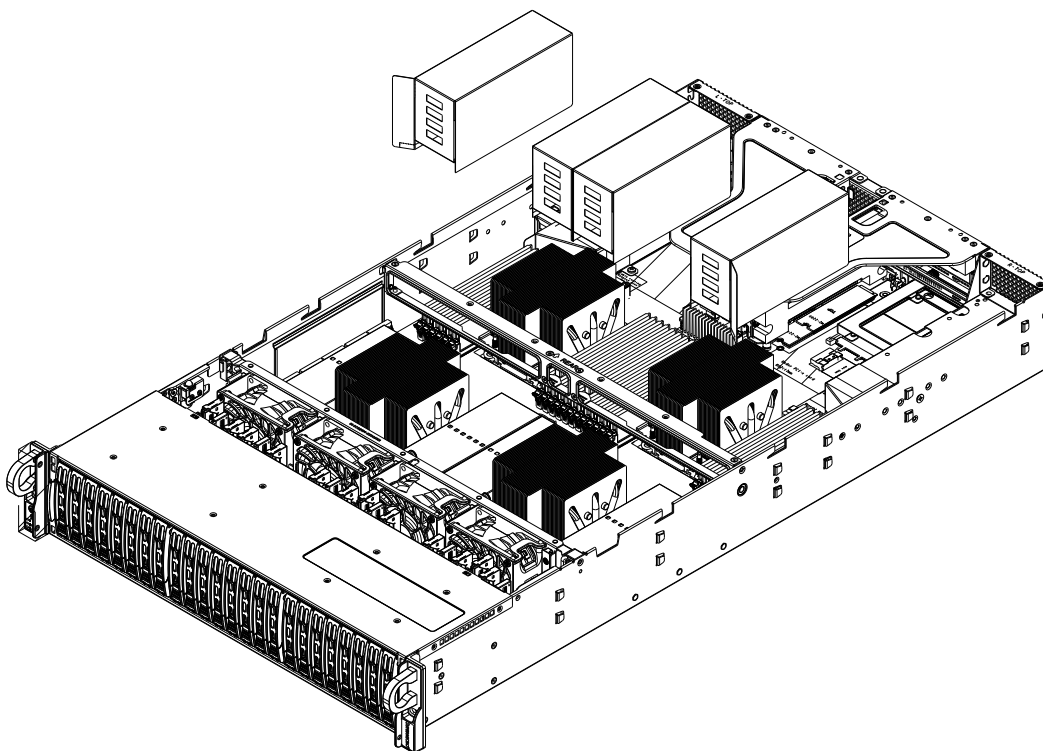

Figure 3-8. Installing Air Shrouds for CPU1/2 DIMMs

Caution: The handles used for pulling the system from the rack are not intended to be used to pick up or lift the system.

Air Shroud for Memory (CPU3/4)

Four 1U air shrouds cool the DIMM slots controlled by CPUs 3 and 4 (see figure below).

Caution: DO NOT perform this service with the system mounted inside the rack.

1. Power down the system as described in Section 3.1.
2. Remove the system from the rack and place it on a bench, then remove the cover as described [previously](#).
3. Place each air shroud over six DIMM slots at a time for both CPU3 and CPU4-controlled DIMM slots, as illustrated below. Close the cover and push the system back into the rack.

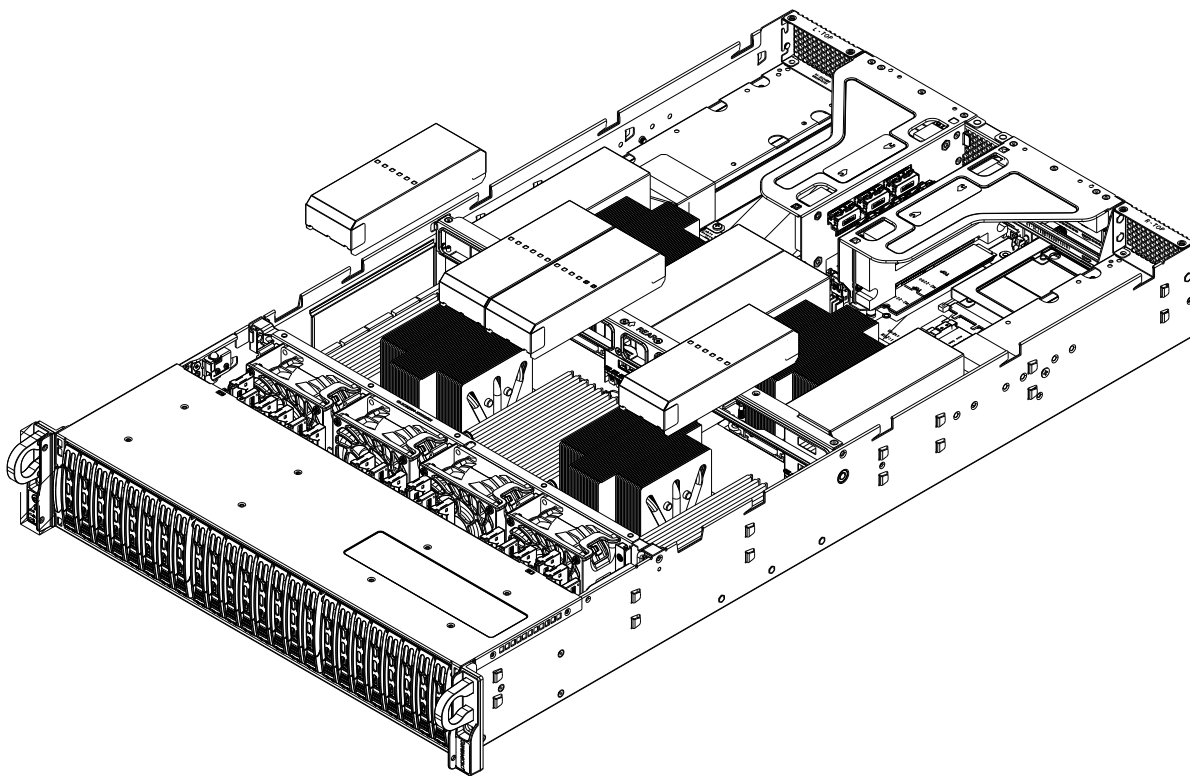

Figure 3-9. Installing Air Shrouds for CPU3/4 DIMMs

Caution: The handles used for pulling the system from the rack are not intended to be used to pick up or lift the system.

Air Shroud for Power

One additional air shroud is used to cool the power supply connection area in the system (see figure below).

Caution: DO NOT perform this service with the system mounted inside the rack.

1. Power down the system as described in Section 3.1.
2. Remove the system from the rack and place it on a bench, then remove the cover as described [previously](#).
3. Place the air shroud over the power supply connectors and secure with the screws and double-sided tape included with the air shroud, as illustrated below.
4. Close the cover and push the system back into the rack.

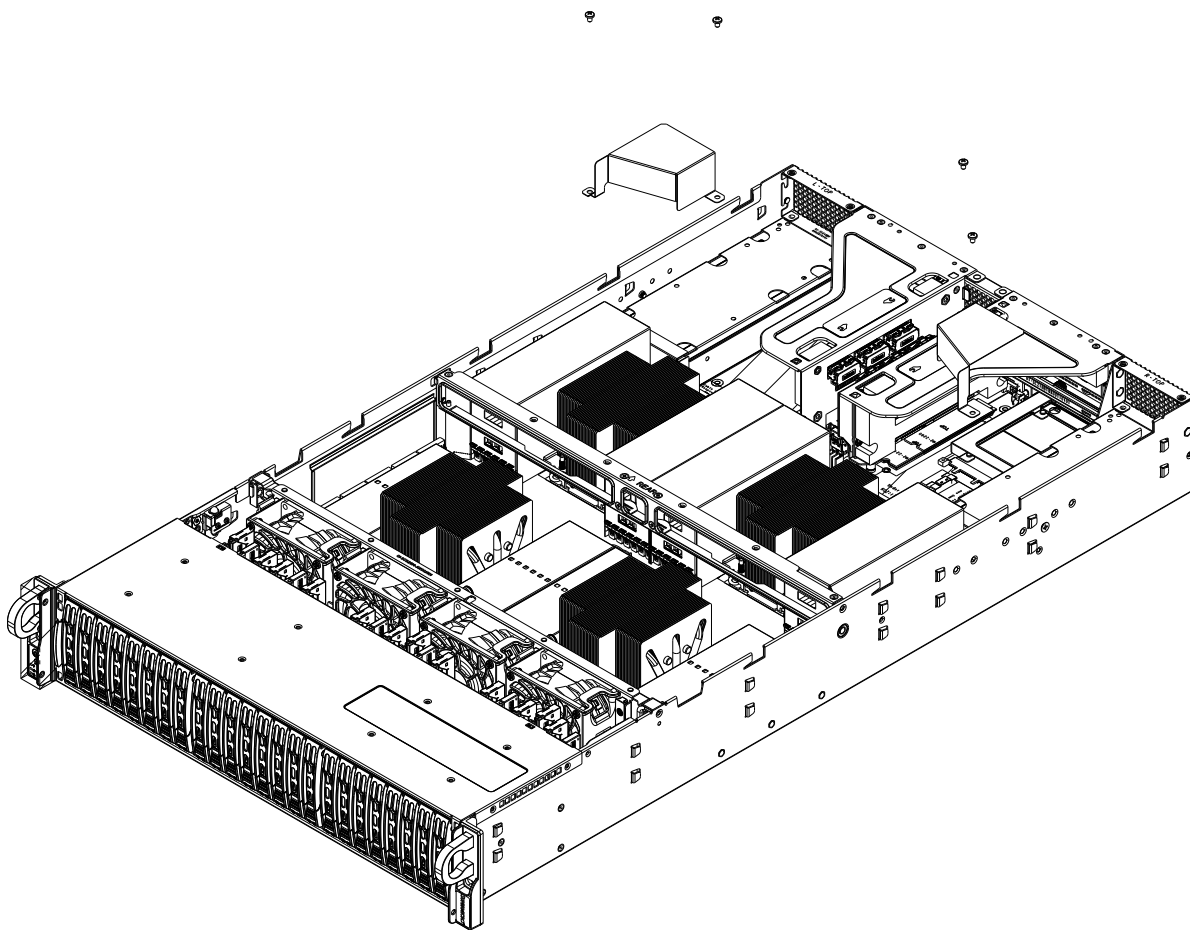

Figure 3-10. Installing Air Shrouds for the Power Connections

Caution: The handles used for pulling the system from the rack are not intended to be used to pick up or lift the system.

3.9 Expansion Cards

The SYS-240P-TNRT includes two riser cards to support the use of expansion (add-on) cards.

Caution: DO NOT perform this service with the system mounted inside the rack.

Installing Expansion Cards

1. Power down the system as described in Section 3.1.
2. Remove the system from the rack and place it on a bench, then remove the cover as described [previously](#).
3. Remove the slimline SAS cable and pull up the riser card brackets.
 - For the right side (looking from the node rear), open the clip of each slot on the right.
 - For the left side, open the clip of each slot.
4. Remove the blank PCI shield from the chassis.
5. Slide the expansion card shield into the open shield slot while plugging the expansion card into the riser card.

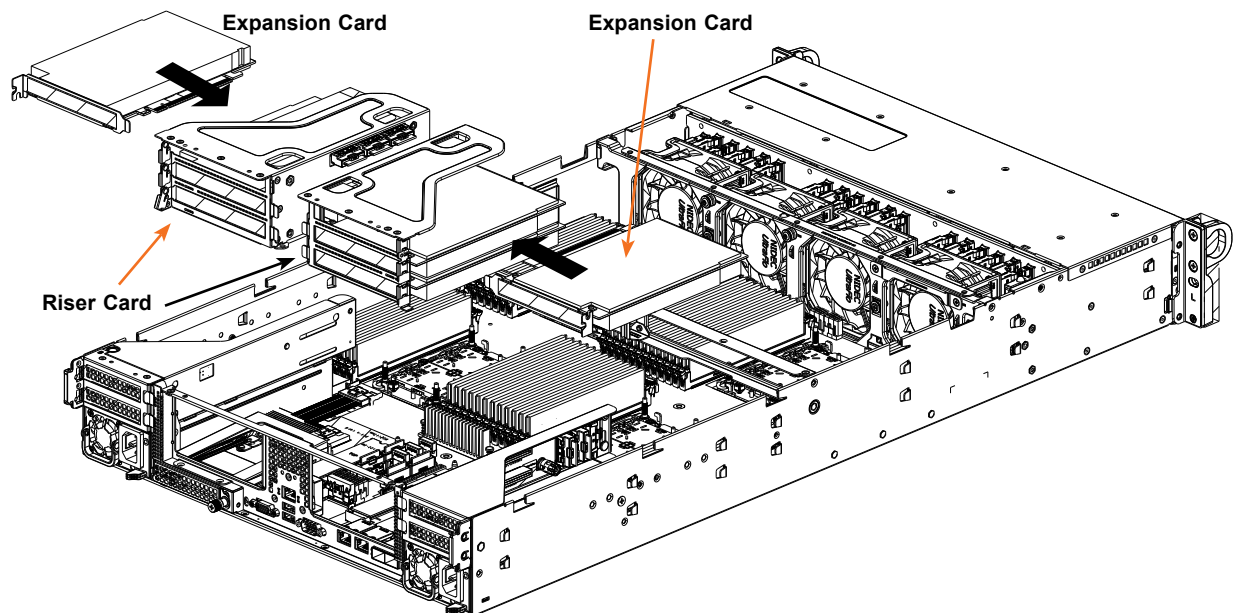

Figure 3-11. Installing Riser Cards

Caution: The handles used for pulling the system from the rack are not intended to be used to pick up or lift the system.

3.10 Power Supply

The system includes two hot-plug, 2000W power supply modules. These modules will automatically sense and operate at an input voltage between 100v to 240v. Note that different input voltages will result in different maximum power output levels.

In the event of a power module failure, the other power module will continue to power the system on its own. Failed power supply modules can be replaced without powering-down the system. Replacement modules can be ordered directly from Supermicro.

An amber light on the power supply is illuminated when the power is switched off. A green light indicates that the power supply is operating.

Replacing the Power Supply

1. Unplug the AC power cord from the failed power supply module.
2. Push and hold the release tab on the back of the power supply.
3. Grasp the handle of the power supply and pull it out of its bay.
4. Push the new power supply module into the power bay until it clicks into the locked position.
5. Plug the AC power cord back into the power supply module.

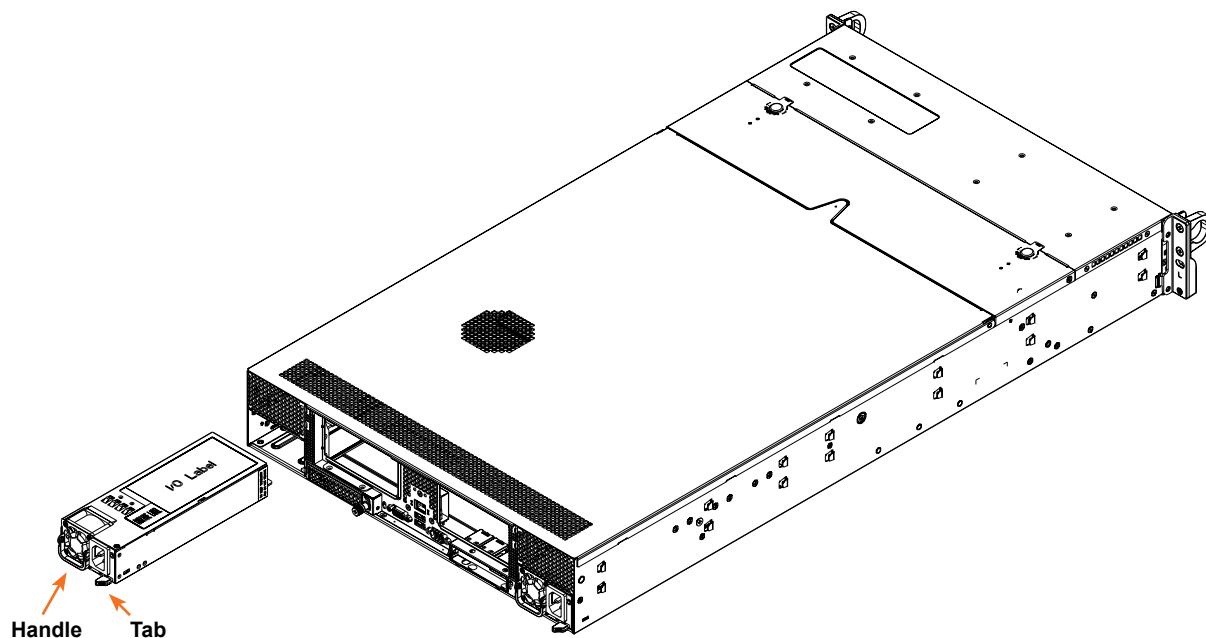

Figure 3-12. Installing a Power Supply Module

3.11 Cable Routing Diagram

Refer to the diagram below for a representation of how the main cables are routed throughout the system. When disconnecting cables to add or replace components, refer to this diagram when adding or replacing components so you can reroute them in the same manner. Proper cable routing is important in maintaining proper airflow through the system.

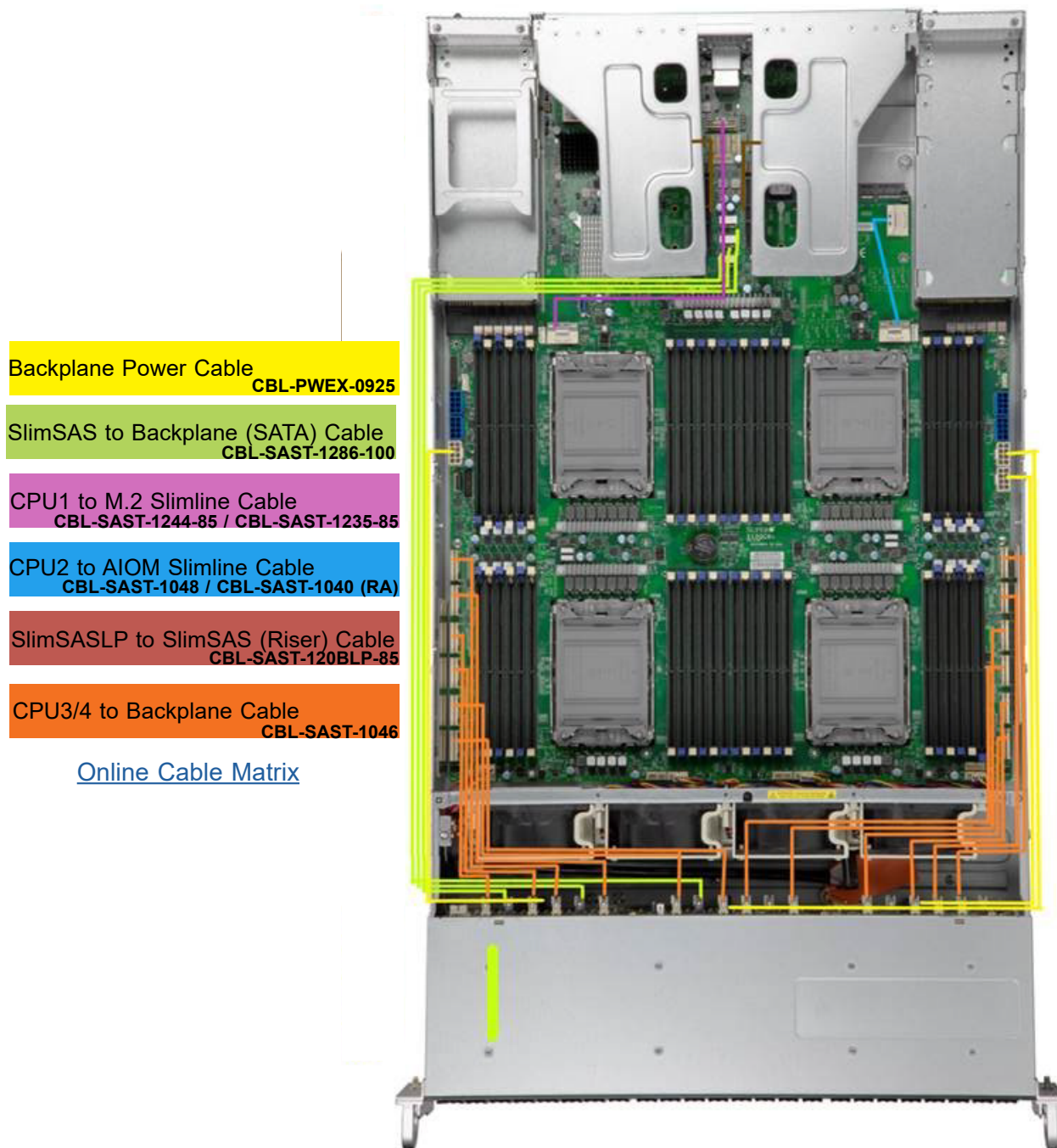

Figure 3-13. Cable Routing Diagram

3.12 BMC

The BMC can be reset using the button on the front control panel or on the chassis rear.

- **Reset**—Press and hold the button. After six seconds, the LED blinks at 2 Hz. The BMC resets and the reset duration is ~250 ms. Then the BMC starts to boot.
- **Restore factory default configuration**—Hold the button for twelve seconds. The LED blinks at 4 Hz while defaults are configured.
- **Firmware update**—the UID LED blinks at 10Hz during a firmware update.

BMC Reset Options	
Event	LED (Green)
Reset	Blinks at 2 Hz
Restore Defaults	Blinks at 4 Hz
Update	Blinks at 10 Hz

Chapter 4

Motherboard Connections

This section describes the connections on the motherboard and provides pinout definitions. Note that depending on how the system is configured, not all connections are required. The LEDs on the motherboard are also described here. A motherboard layout indicating component locations may be found in [Chapter 1](#). More detail can be found in the [Motherboard Manual](#). Please review the Safety Precautions in [Appendix A](#) before installing or removing components.

4.1 Power Connections

Two power connections supply the motherboard and several more supply for onboard devices.

Main Power Connections

Two Power Delivery I²C1/2 Boards (PDB), located at PSU1 and PSU2, are used to provide main power to your system.

Important: To provide adequate power to your system, be sure to connect the Power Delivery Boards (PSU1/2) and all 8-pin PWR connectors (BP_PWR1/2/3 & GPU_PWR1/2/3/4) to the power supply. Failure to do so may void the manufacturer warranty on your power supply and motherboard.

Backplane Power Connectors & GPU Power Connectors

In addition to the main power headers, three 8-pin power connectors (BP_PWR1/2/3) are used for backplane devices. Another four 8-pin power connectors (GPU_PWR1/2/3/4) are for GPU device use. These 8-pin power connectors meet the ATX SSI EPS 12V specification and must be connected to your power supply to provide adequate power to your system.

12V 8-pin Power Pin Definitions	
Pin#	Definition
1 - 4	Ground
5 - 8	+12V

PDB Cable Connectors for CPU3/CPU4

Two PDB (Power Delivery Board) cable connectors for CPU3 and CPU4 are located at J26 and J47. J47 is used for CPU3, and J26 is for CPU4. See the layout below for the locations for J47 and J26.

Power Connectors for PCIe 3.0 x16 HIO Slots (J5/J6)

Two 6-pin power connectors used for PCIe 3.0 x16 High_Speed (HIO) slots are located at J5/J6. J5 is used for the left side PCIe 3.0 x16 slot (P1_HIO_L1PCIE), while J6 is for the right side PCIe 3.0 x16 slot (P2_HIO_R1PCIE). See the layout below for the locations for J5 and J6.

4.2 Headers and Connectors

Fan Headers

There are twelve 6-pin fan headers (FAN1 - FAN12) on the motherboard. The fan speed control for these fans are supported by Thermal Management via BMC.

TPM/Port 80 Header

The JTPM1 header is used to connect a Trusted Platform Module (TPM)/Port 80, which is available from Supermicro (optional). A TPM/Port 80 connector is a security device that supports encryption and authentication in hard drives. It allows the motherboard to deny access if the TPM associated with the hard drive is not installed in the system. For more information on TPM go to <http://www.supermicro.com/manuals/other/TPM.pdf>.

Trusted Platform Module Header Pin Definitions			
Pin#	Definition	Pin#	Definition
1	+3.3V	2	SPI_CS#
3	RESET#	4	SPI_MISO
5	SPI_CLK	6	GND
7	SPI_MOSI	8	NC
9	+3.3V Stdbby	10	SPI_IRQ#

VROC RAID Key Header

A VROC RAID Key header is located at JRK1 on the motherboard. For NVMe RAID support, install a VROC RAID Key on JRK1 as shown in the illustration below.

Intel VROC Key Pin Definitions	
Pin#	Definition
1	Ground
2	3.3V Standby
3	Ground
4	PCH RAID Key

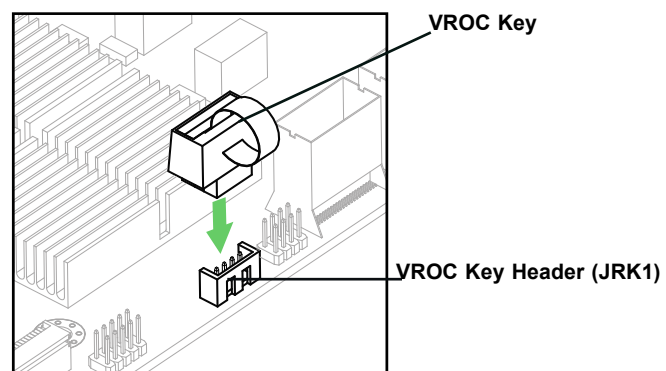

Note: The graphics contained in this user's manual are for illustration purposes only. The components installed in your system may or may not look exactly the same as the graphics shown in the manual.

Standby Power

The Standby Power header is located at JSTBY1 on the motherboard. You must have a card with a Standby Power connector and a cable to use this feature. Refer to the table below for pin definitions.

Standby Power Pin Definitions	
Pin#	Definition
1	+5V Standby
2	Ground
3	No Connection

4-pin BMC External I²C Header

A System Management Bus header for BMC is located at JIPMB1. Connect the appropriate cable here to use the IPMB I²C connection on your system. Refer to the table below for pin definitions.

External I ² C Header Pin Definitions	
Pin#	Definition
1	Data
2	Ground
3	Clock
4	No Connection

Chassis Intrusion

A Chassis Intrusion header is located at JL1 on the motherboard. Attach the appropriate cable from the chassis to inform you when the chassis is opened. Refer to the table below for pin definitions.

Chassis Intrusion Pin Definitions	
Pin#	Definition
1	Intrusion Input
2	Ground

Control Panel

JF1 contains header pins for various control panel connections. See the figure below for the pin locations and definitions of the control panel buttons and LED indicators.

All JF1 wires have been bundled into a single cable to simplify this connection. Make sure the red wire plugs into pin 1 as marked on the motherboard. The other end connects to the control panel PCB board.

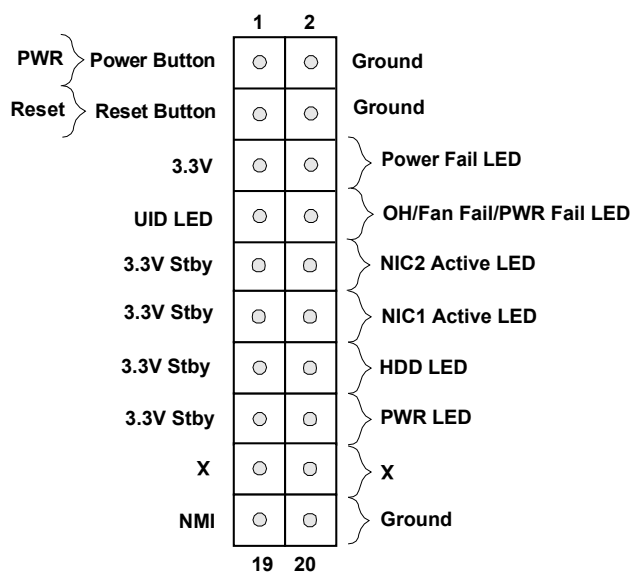

Figure 4-1. JF1 Control Panel Pins

Power Button

The Power Button connection is located on pins 1 and 2 of JF1. Momentarily contacting both pins will power on/off the system. Refer to the table below for pin definitions.

Power Button Pin Definitions (JF1)	
Pin#	Definition
1	Signal
2	Ground

Reset Button

The Reset Button connection is located on pins 3 and 4 of JF1. Momentarily contacting both pins will reset the system. Refer to the table below for pin definitions.

Reset Button Pin Definitions (JF1)	
Pin#	Definition
3	Reset
4	Ground

Power Fail LED

The Power Fail LED connection is located on pins 5 and 6 of JF1. Refer to the table below for pin definitions.

Power Fail LED Pin Definitions (JF1)	
Pin#	Definition
5	3.3V
6	PWR Supply Fail

Information LED (OH/Fan Fail/PWR Fail/UID LED)

The Information LED (OH/Fan Fail/PWR Fail/UID LED) connection is located on pins 7 and 8 of JF1. The LED on pin 7 is active when the UID switch on the rear I/O panel is pressed. The LED on pin 8 provides warnings of overheating, power failure, or fan failure. Refer to the tables below for more information.

Information LED-UID/OH/PWR Fail/Fan Fail LED Pin Definitions (JF1)	
Status	Description
Solid red	An overheating condition has occurred. (This may be caused by cable congestion).
Blinking red (1Hz)	Fan failure: check for an inoperative fan.
Blinking red (0.25Hz)	Power failure: check for a non-operational power supply
Solid blue	Local UID is activated. Use this function to locate a unit in a rack mount environment that might be in need of service.
Blinking blue (300 msec)	Remote UID is on. Use this function to identify a unit from a remote location that might be in need of service.

NIC1/NIC2 (LAN1/LAN2)

The NIC (Network Interface Controller) LED connection for LAN port 1 is located on pins 11 and 12 of JF1, and LAN port 2 is on pins 9 and 10. These LAN ports support 10G LAN Ethernet connections. Attach the NIC LED cables here to display network activity. Refer to the table below for pin definitions.

LAN1/LAN2 LED Pin Definitions (JF1)	
Pins	Definition
9	NIC 2 Activity LED
11	NIC 1 Activity LED

HDD LED

The HDD LED connection is located on pins 13 and 14 of JF1. Attach a cable to pins 13 and 14 to show hard drive activity status. Refer to the table below for pin definitions.

HDD LED Pin Definitions (JF1)	
Pins	Definition
13	3.3V Stdby
14	HDD Active

Power LED

The Power LED connection is located on pins 15 and 16 of JF1. Refer to the table below for pin definitions.

Power LED Pin Definitions (JF1)	
Pins	Definition
15	3.3V
16	PWR LED

NMI Button

The non-maskable interrupt (NMI) button header is located on pins 19 and 20 of JF1. Refer to the table below for pin definitions.

NMI Button Pin Definitions (JF1)	
Pins	Definition
19	Control
20	Ground

4.3 Input/Output Ports

Rear I/O Ports

See the figure below for the locations and descriptions of the I/O ports on the rear of the motherboard.

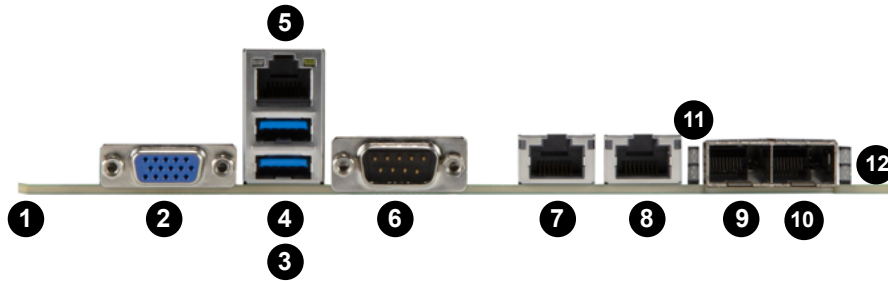

Rear I/O Ports					
#	Description	#	Description	#	Description
1	UID Switch/LED (on the motherboard)	5	BMC_LAN	9	(10G) LAN3
2	VGA	6	COM1	10	(10G) LAN4
3	USB 0 (3.0)	7	(10G) LAN1	11	LEDT2 (LAN3 LED)
4	USB 1 (3.0)	8	(10G) LAN2	12	LEDT1 (LAN4 LED)

VGA Connections

There are two VGA connections on the X12QCH+-P. The rear VGA port is located at JVGA1 on the rear I/O panel, and the front VGA header is located at FP2 on the motherboard. These VGA connections provide analog interface support between the computer and the video displays.

COM Port

A COM port that supports a serial link interface is included on the rear I/O panel.

10G LAN Ports (LAN1/LAN2/LAN3/LAN4) & BMC LAN

Four 10G LAN ports (LAN1/LAN2/LAN3/LAN4) and a dedicated BMC LAN port (BMC LAN) are located on the rear I/O panel. LAN1/LAN2 ports are supported by the RJ45 ethernet connections and require RJ45 cables. LAN3/LAN4 ports support SFP28. The dedicated BMC LAN, located above the USB0/1 ports on the rear I/O panel, provides LAN support for the BMC (Baseboard Management Controller). The LEDs for LAN1/LAN2 are on the LAN connectors. The LED indicator for LAN3 is located on LEDT2, and LED for LAN4 is on LEDT1. Please also refer to the LED Indicator section for LAN LED information.

Universal Serial Bus (USB) Ports and Headers

Two USB 3.0 ports (USB0/1) are located on the rear I/O panel, and an internal Type A USB 3.0 header (USB2) is located on the motherboard to provide front access.

Rear I/O Panel USB 0/1 (3.0) Pin Definitions			
Pin#	Definition	Pin#	Definition
A1	VBUS	B1	Power
A2	D-	B2	USB_N
A3	D+	B3	USB_P
A4	GND	B4	GND
A5	Stda_SSRX-	B5	USB3_RN
A6	Stda_SSRX+	B6	USB3_RP
A7	GND	B7	GND
A8	Stda_SSTX-	B8	USB3_TN
A9	Stda_SSTX+	B9	USB3_TP

Type A USB 2 (3.0) Pin Definitions			
Pin#	Definition	Pin#	Definition
1	VBUS	5	SSRX-
2	USB_N	6	SSRX+
3	USB_P	7	GND
4	Ground	8	SSTX-
		9	SSTX+

Unit Identifier Switch and UID LED Indicator

A Unit Identifier (UID) switch and a rear UID LED (LED1) are located on the rear I/O panel. The front UID LED is located on pins 7 & 8 of the front panel control header (JF1). When you press the rear UID switch, both front and rear UID LEDs will be turned on. Press the UID switch again to turn off the LED indicators. The UID indicators provide easy identification of a system in a rack environment.

Note: UID can also be triggered via BMC on the motherboard.

UID LED Pin Definitions	
Color	Status
Blue: On	Unit Identified

4.4 Jumpers

Explanation of Jumpers

To modify the operation of the motherboard, jumpers are used to choose between optional settings. Jumpers create shorts between two pins to change the function associated with it. Pin 1 is identified with a square solder pad on the printed circuit board. See the motherboard layout page for jumper locations.

Note: On a two-pin jumper, "Closed" means the jumper is on both pins and "Open" indicates the jumper is either on only one pin or has been completely removed.

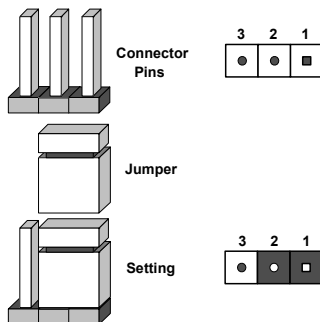

CMOS Clear

JBT1 is used to clear CMOS, which will also clear any passwords. Instead of pins, this jumper consists of contact pads to prevent accidentally clearing the contents of CMOS.

To Clear CMOS

1. First power down the system and unplug the power cord(s).
2. Remove the cover of the chassis to access the motherboard and remove the battery from the motherboard.
3. Short the CMOS pads with a metal object such as a small screwdriver for at least four seconds.
4. Remove the screwdriver (or shorting device).
5. Replace the cover, reconnect the power cord(s), and power on the system.

Notes: Clearing CMOS will also clear all passwords. Do not use the PW_ON connector to clear CMOS.

Manufacturing Mode (ME Mode Select)

Close pins 2-3 of jumper JPME2 to bypass SPI flash security and force the system to operate in manufacturing mode, which will allow the user to flash the system firmware from a host server for system setting modifications. The default setting is Normal.

ME Select Jumper Settings	
Jumper Setting	Definition
Pins 1-2	Normal (Default)
Pins 2-3	Manufacturer Mode

Watch Dog

JWD1 controls the Watch Dog function. Watch Dog is a monitor that can reboot the system when a software application hangs. Jumping pins 1-2 will cause Watch Dog to reset the system if an application hangs. Jumping pins 2-3 will generate a non-maskable interrupt signal for the application that hangs. Watch Dog must also be enabled in BIOS. The default setting is Reset.

Note: When Watch Dog is enabled, the user needs to write their own application software to disable it.

Watch Dog Jumper Settings	
Jumper Setting	Definition
Pins 1-2	Reset (Default)
Pins 2-3	NMI
Open	Disabled

10G LAN Ports Enable/Disable

Jumper JPTG1 allows the user to enable the onboard 10G LAN ports. The default setting is pins 1-2 to enable the connection.

10G LAN Enable/Disable Jumper Settings	
Jumper Setting	Definition
Pins 1-2	Enabled (Default)
Pins 2-3	Disabled

Power-Failure Throttling Enable

J34 is a power-failure throttling jumper which will allow the user to enable the CPU throttling mode when a power failure occurs. The default setting is on pins 1 and 2 for normal operation.

Power-Failure Throttling Jumper Settings	
Jumper Setting	Definition
Pins 1-2	Normal (Default)
Pins 2-3	Power-Failure Throttling Enable

Select Switch for FP1_Reset Button or UID Button

Jumper J58 is used to select between the FP1_Reset button and the UID button. The default setting is to close J58 to use the UID button.

Select Switch for FP1_Reset Button & UID Button Jumper Settings	
Jumper Setting	Definition
Closed	UID Button (Default)
Open	FP1_Reset Button

4.5 LED Indicators

10G LAN1/LAN2 LEDs

Two RJ45 Ethernet 10G LAN ports (LAN 1 and LAN 2) are located on the rear I/O panel of the motherboard. Each Ethernet LAN port has two LEDs. The green LED indicates activity, while the other Link LED may be green, amber, or off to indicate the speed of the connection. Refer to the tables below for more information.

10G LAN1/2 Activity LED (Right) LED State		
Color	Status	Definition
Green	Flashing	Active

LAN1/2 Link LED (Left) LED State	
LED Color	Definition
Green	10Gbps

BMC LAN LEDs

In addition to LAN1 and LAN2, an BMC LAN is also located on the rear I/O panel. The amber LED on the right indicates activity, while the green LED on the left indicates the speed of the connection. Refer to the table below for more information.

BMC LAN LEDs		
	Color/State	Definition
Link (left)	Green: Solid Amber: Solid	100 Mbps 1 Gbps
Activity (Right)	Amber: Blinking	Active

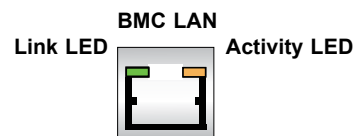

10G LAN3/4 LEDs

Two 10G LAN ports (LAN3/LAN4) that support SFP28 are also located on the rear I/O panel. The activity LED for LAN3 is located on LEDT2, while the activity LED for LAN4 is on LEDT1. Refer to the tables below for more information.

10G LAN3/4 Activity LED Indicators LED State	
LED#	LAN#
LEDT1	LAN4
LEDT2	LAN3

10G LAN3/4 Activity LEDs LED State		
Color	Status	Definition
Green	Flashing	Active

Unit ID LED

A rear UID LED indicator (LED1) is located next to the UID switch. This UID indicator provides easy identification of a system unit that may need service.

UID LED LED Indicator	
LED Color	Definition
Blue: On	Unit Identified

Onboard Power LED

The Onboard Power LED is located at LED2. When this LED is on, the system power is on. Be sure to turn off the system power and unplug the power cord before removing or installing components.

Onboard Power LED Indicator	
LED Color	Definition
Off	System Power Off
Green	System Power On

BMC Heartbeat LED

A BMC Heartbeat LED is located at BMC_HB_LED1 on the motherboard. When this LED is blinking, the BMC is functioning normally.

BMC Heartbeat LED Indicator	
LED Color	Definition
Green: Blinking	BMC Normal

4.6 Storage Ports

I-SATA 3.0 and S-SATA 3.0 Connectors

The X12QCH+ has eight I-SATA 3.0 ports (I-SATA0-3, I-SATA4-7) and four S-SATA (S-SATA0-3) in addition to the M.2 HC-S-SATA 4/5 slots. These SATA ports are supported by the Intel® C621A chipset

PCIe M.2 Slot & M.2-HC S-SATA4/5 Slots

A PCIe 3.0 M.2 slot (PCIe M.2) is located next to the TPM/Port80. In addition, two M.2-HC S-SATA slots (JMD1/JMD2) also support PCIe 3.0 x4 for NVMe/SATA Solid State Devices (SSDs). These M.2 slots support 2280 and 22110 form factors via SlimSAS x8 cables (required). The M.2 slots allow for a variety of card sizes with increased functionality and spatial efficiency.

Chapter 5

Software

After the hardware has been installed, you can install the Operating System (OS), configure RAID settings and install the drivers.

5.1 Microsoft Windows OS Installation

If you will be using RAID, you must configure RAID settings before installing the Windows OS and the RAID driver. Refer to the RAID Configuration User Guides posted on our website at www.supernmicro.com/support/manuals.

Installing the OS

1. Create a method to access the MS Windows installation ISO file. That might be a USB flash or media drive, or the BMC KVM console.
2. Retrieve the proper RST/RSTe driver. Go to the Supermicro web page for your motherboard and click on "Download the Latest Drivers and Utilities", select the proper driver, and copy it to a USB flash drive.
3. Boot from a bootable device with Windows OS installation. You can see a bootable device list by pressing **F11** during the system startup.

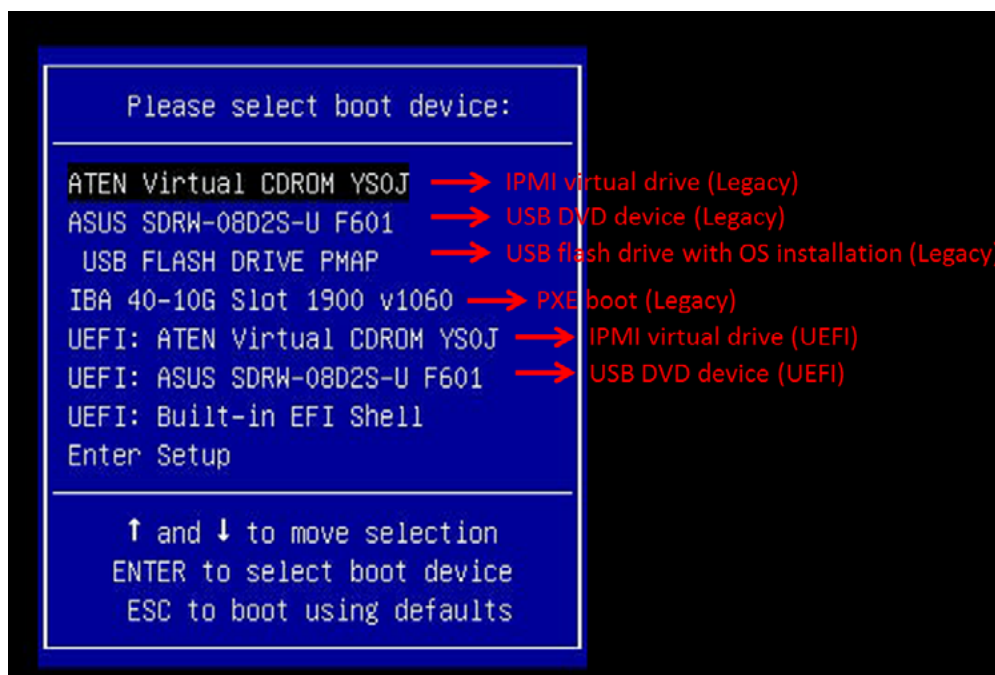

Figure 5-1. Select Boot Device

4. During Windows Setup, continue to the dialog where you select the drives on which to install Windows. If the disk you want to use is not listed, click on “Load driver” link at the bottom left corner.

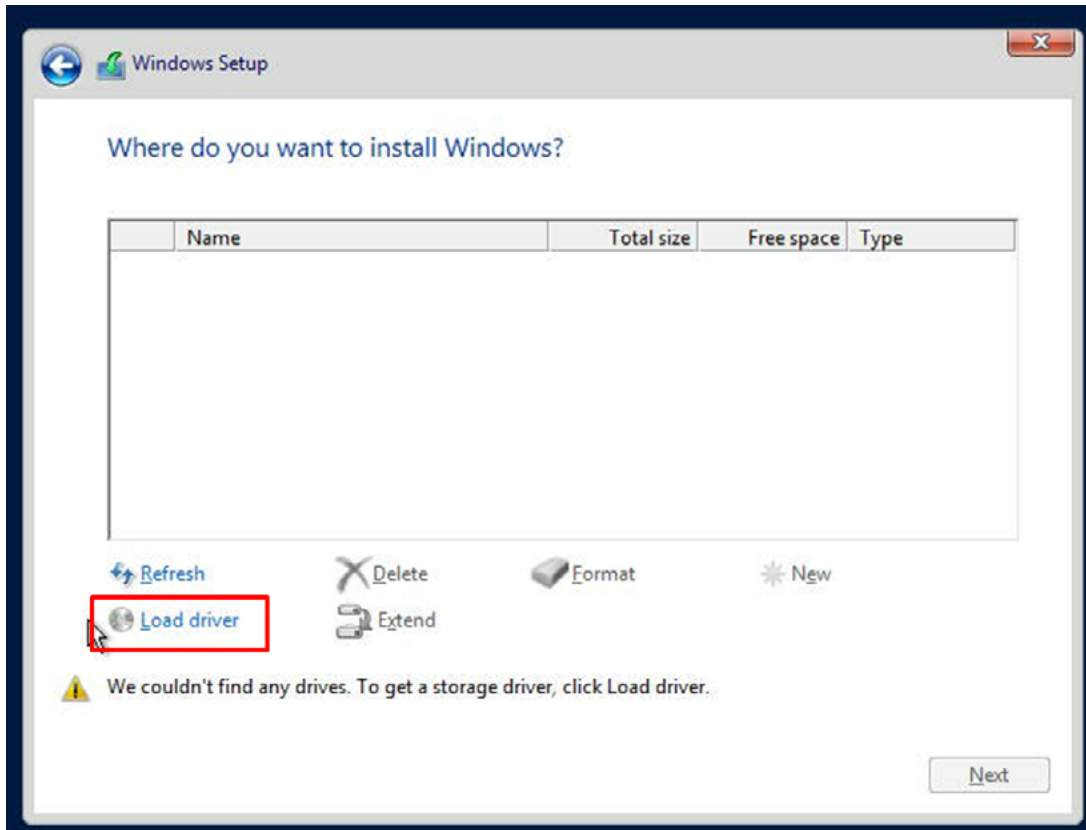

Figure 5-2. Load Driver Link

To load the driver, browse the USB flash drive for the proper driver files.

- For RAID, choose the SATA/sSATA RAID driver indicated then choose the storage drive on which you want to install it.
 - For non-RAID, choose the SATA/sSATA AHCI driver indicated then choose the storage drive on which you want to install it.
5. Once all devices are specified, continue with the installation.
 6. After the Windows OS installation has completed, the system will automatically reboot multiple times.

5.2 Driver Installation

The Supermicro website contains drivers and utilities for your system at <https://www.supermicro.com/wdl/driver>. Some of these must be installed, such as the chipset driver.

After accessing the website, go into the CDR_Images (in the parent directory of the above link) and locate the ISO file for your motherboard. Download this file to a USB flash or media drive. (You may also use a utility to extract the ISO file if preferred.)

Another option is to go to the Supermicro website at <http://www.supermicro.com/products/>. Find the product page for your motherboard, and "Download the Latest Drivers and Utilities".

Insert the flash drive or disk and the screenshot shown below should appear.

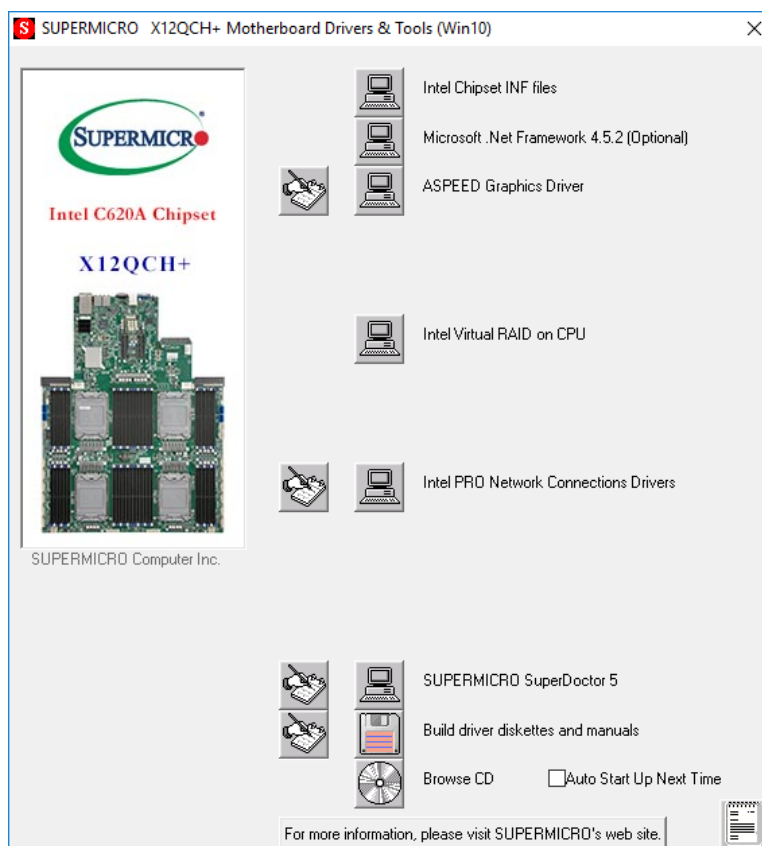

Figure 5-3. Driver & Tool Installation Screen

Note: Click the icons showing a hand writing on paper to view the readme files for each item. Click the computer icons to the right of these items to install each item (from top to the bottom) one at a time. **After installing each item, you must re-boot the system before moving on to the next item on the list.** The bottom icon with a CD on it allows you to view the entire contents.

5.3 SuperDoctor® 5

The Supermicro SuperDoctor 5 is a program that functions in a command-line or web-based interface for Windows and Linux operating systems. The program monitors such system health information as CPU temperature, system voltages, system power consumption, fan speed, and provides alerts via email or Simple Network Management Protocol (SNMP).

SuperDoctor 5 comes in local and remote management versions and can be used with Nagios to maximize your system monitoring needs. With SuperDoctor 5 Management Server (SSM Server), you can remotely control power on/off and reset chassis intrusion for multiple systems with SuperDoctor 5 or BMC. SuperDoctor 5 Management Server monitors HTTP, FTP, and SMTP services to optimize the efficiency of your operation.

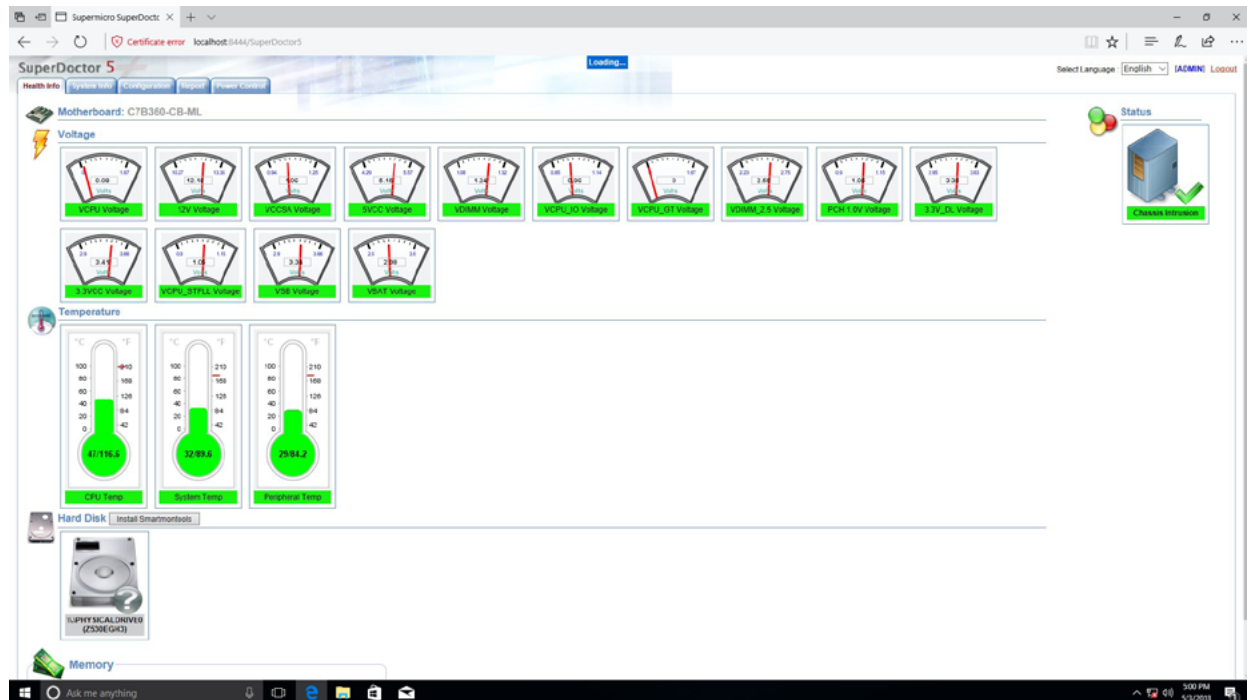

Figure 5-4. SuperDoctor 5 Interface Display Screen (Health Information)

5.4 BMC

The X12QCH+-P provides remote access, monitoring and management through the baseboard management controller (BMC) and other management controllers distributed among different system modules. There are several BIOS settings that are related to BMC. For general documentation and information on BMC, visit our website at:

www.supermicro.com/en/solutions/management-software/bmc-resources

BMC ADMIN User Password

For security, each system is assigned a unique default BMC password for the ADMIN user. This can be found on a sticker on the chassis and a sticker on the motherboard. The sticker also displays the BMC MAC address.



Figure 5-5. BMC Password Label

See [Chapter 1](#) for label location.

Chapter 6

Optional Components

This chapter describes optional system components and installation procedures.

6.1 Optional Parts List

Optional Parts List		
Description	Part Number	Quantity
Tool-less black hot-swap 2.5" NVMe drive tray	MCP-220-00167-0B	1-24
Black hot-swap 2.5" NVMe drive tray (orange tab, w/ key lock)	MCP-220-00127-0B	1-24
Black Gen3 hot-swap 2.5" tool-less SAS/SATA HDD tray	MCP-220-00147-0B	1-16
Add-on Cards	AOC-VROCPREMOD	
	AOC-VROCSTNMOD	
CacheVaults	BTR-TFM8G-LSICVM02 & BKT-BBU-BRACKET-05	
	BTR-TFM8G-LSICVM02 & MCP-240-00127-0N	
Network Cards	AOC-S40G-i2Q	
	AOC-SGP-i2	
	AOC-SGP-i4	
	AOC-STG-b4S	
	AOC-STGN-i2S	
	AOC-STGN-i1S	
AIOM Cards	AOC-STG-i2T	
	AOC-AG-i4SM	
	AOC-AG-i4M	
	AOC-AG-i2M	
Software	AOC-ATG-i2SM	
	SFT-OOB-LIC	1
PCIe Riser Card	SFT-DCMS-Single	1
	RSC-H2-68G4	1

6.2 Storage Control Cards

Storage Control Card Options		
Part Number	Cable	HDD Configuration
AOC-S3008L-L8i x1 or AOC-S3108L-H8iR x1 or AOC-S3108L-H8iR-16DD x1	CBL-SAST-1295-100 (x2)	8 SAS3 HDDs
AOC-S3008L-L8i x2 or AOC-S3108L-H8iR x2 or AOC-S3108L-H8iR-16DD x2	CBL-SAST-1295-100 (x4)	16 SAS3 HDDs
AOC-S3008L-L8i x3 or AOC-S3108L-H8iR x3 or AOC-S3108L-H8iR-16DD x3	CBL-SAST-1295-100 x6	24 SAS3 HDDs
AOM-TPM-9670V or AOM-TPM-9671V	n/a	TPM security module

6.3 Network Cards

Network Card Options	
Part Number	Description
AOC-S40G-i2Q	Standard LP 2-port 40GbE controller, based on Intel Fortville XL710
AOC-SGP-i2	Standard LP, 2x GbE RJ45, PCIe x4, Intel i350AM2
AOC-SGP-i4	Standard LP, 4x GbE RJ45, PCIe x4, Intel i350
AOC-STG-b4S	Standard LP, 4x 10GbE SFP+, PCIe x8, Broadcom BCM57840S
AOC-STGN-i2S	Standard LP, 2x 10GbE SFP+, PCIe x8, Intel 82599ES
AOC-STGN-i1S	Standard LP, 1x 10GbE SFP+, PCIe x8, Intel 82599EN
AOC-STG-i2T	Standard LP, 2x 10GbE RJ45, PCIe x8, Intel X540

See [Chapter 3](#) for the riser card installation procedure.

6.4 Intel Virtual RAID on CPU (VROC)

Intel® Virtual RAID on CPU (Intel VROC) is an enterprise RAID solution for NVMe SSDs directly attached to Intel Xeon Scalable processors. Intel Volume Management Device (VMD) is an integrated controller inside the CPU PCIe root complex.

- A single processor supports up to 12 NVMe SSDs and up to 6 RAID arrays.
- A dual processor system supports up to 24 NVMe SSDs and 12 RAID arrays.

Strip sizes are 4K, 8K, 16K, 32K, 64K, 128K.

Requirements and Restrictions

- **Intel VROC is only available when the system is configured for UEFI boot mode.**
- To enable the **mdadm** command and support for RSTe, install the patch from
 - Linux: <https://downloadcenter.intel.com/download/28158/Intel-Virtual-RAID-on-CPU-Intel-VROC-and-Intel-Rapid-Storage-Technology-enterprise-Intel-RSTe-Driver-for-Linux>
 - Windows: <https://downloadcenter.intel.com/download/28108/Intel-Virtual-RAID-on-CPU-Intel-VROC-and-Intel-Rapid-Storage-Technology-enterprise-Intel-RSTe-Driver-for-Windows>
- To enable Intel VROC, a hardware key must be inserted on the motherboard, and the appropriate processor's Virtual Management Devices must be enabled in the BIOS setup.
- It is possible to enable Intel VROC without a hardware key installed, but only RAID0 will be enabled.
- Intel VROC is not compatible with secure boot. This feature must be disabled.
- When creating bootable OS RAID1 devices, you must have both devices on the same CPU, and a VMD on that CPU.
- Spanning drives when creating RAID devices is not recommended to due to performance issues, even though it is supported.

Supported SSDs and Operating Systems

To see the latest support information: <https://www.intel.com/content/www/us/en/support/articles/000030310/memory-and-storage/ssd-software.html>

Additional Information

Additional information is available on the product page for the Supermicro add-on card and the linked manuals.

www.supermicro.com/products/accessories/addon/AOC-VROCxxxMOD.cfm

Hardware Key

The Intel VROC hardware key is a license key that detects the Intel VROC SKU and activates the function accordingly. The key must be plugged into the Supermicro motherboard (connector JRK1). The key options are:

Intel® VROC Keys			
VROC Package	Description	Part Number	Intel MM Number
Standard	RAID 0, 1, 10 Supports 3rd party SSDs	AOC-VROCSTNMOD	951605
Premium	RAID 0, 1, 5, 10 Supports 3rd party SSDs	AOC-VROCPREMOD	951606
Intel SSD only	RAID 0, 1, 5, 10 Supports Intel SSDs only	AOC-VROCINTMOD	956822

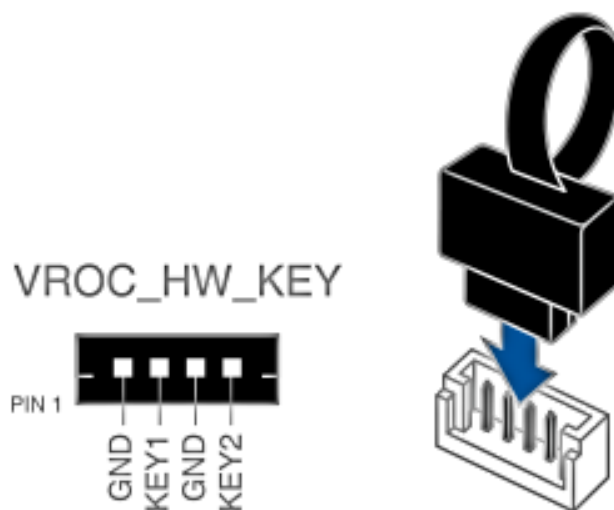

Figure 6-1. Intel® VROC RAID Key and Motherboard Connector JRK1

Enabling NVMe RAID

RAID for NVMe SSDs must be enabled through the UEFI BIOS.

1. Install the patch as described in the Restrictions and Requirements section on a previous page.
2. Reboot the server.
3. Press [DEL] key to enter BIOS.
4. Switch to **Advanced > Chipset Configuration > North Bridge > IIO Configuration > Intel® VMD Technology > CPU3 & CPU4**.
5. **Enable** the VMD according to the following rules.
 - For U.2 NVMe, enable all the sub-items under each PStack, based on the your model server:
 - For M.2 NVMe or NVMe AIC, enable the VMD according to which AOC card/slot it used.

Examples for some U.2 configurations follow.

6. Press [F4] to save the configuration and reboot the system.
7. Press [DEL] to enter BIOS.
8. Switch to **Advanced > Intel(R) Virtual RAID on CPU > All Intel VMD Controllers > Create RAID Volume**.
9. Set **Name**.
10. Set **RAID Level**.
11. If cross-controller RAID is required, select **Enable RAID spanned over VMD Controller** as shown in Figure 6-??.
12. Select specific disks for RAID with an [X].
 - RAID0: Select at least two [2 - 24] disks
 - RAID1: Select only two disks
 - RAID5: Select at least three [3 - 24] disks
 - RAID10: Select only four disks

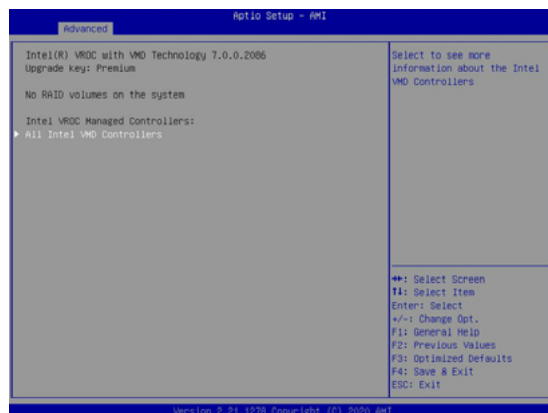
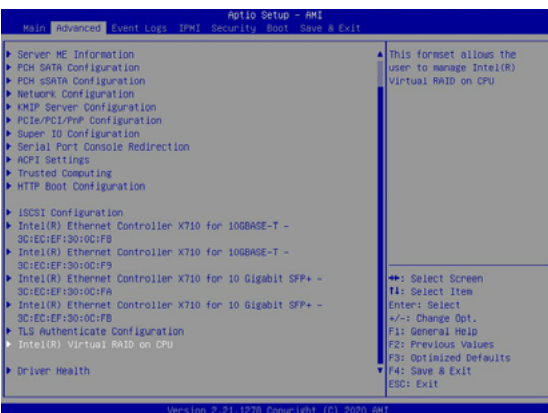
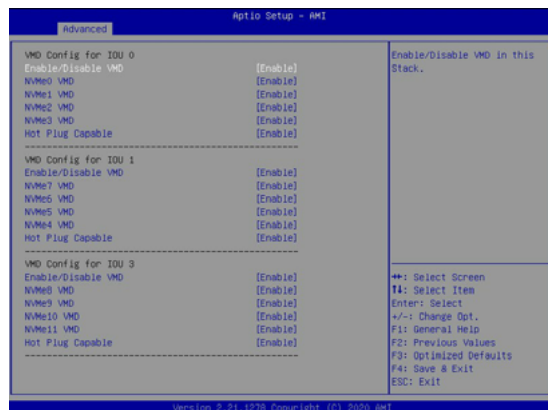
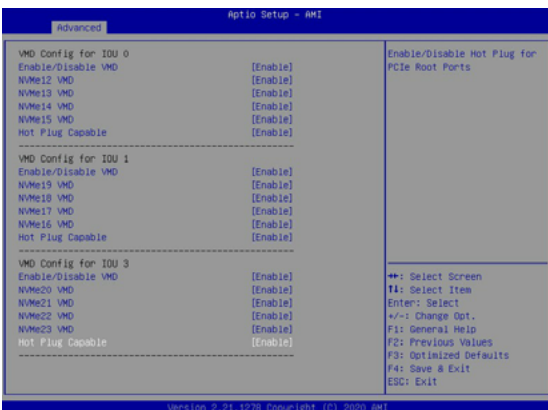
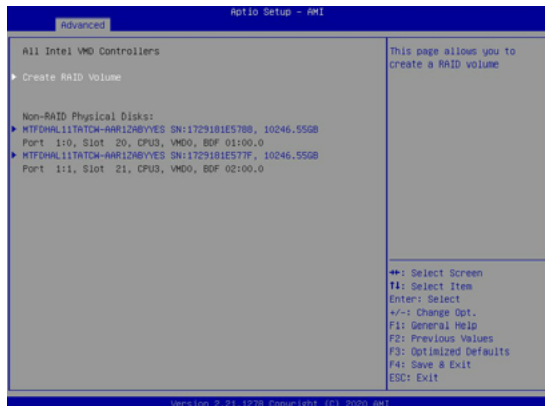

Figure 6-2. BIOS VMD Setting Examples



13. Select **Strip Size** (Default 64KB).
14. Select **Create Volume**.
15. If another RAID is needed, start again at step 6.
16. Press [F4] to save and reboot.

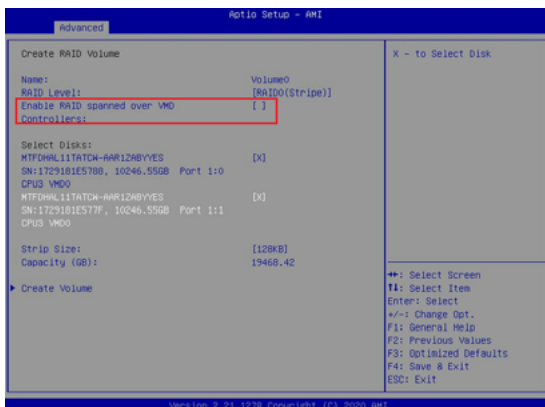

Figure 6-3. Created Volume *without* enabling RAID spanned over VMD Controller

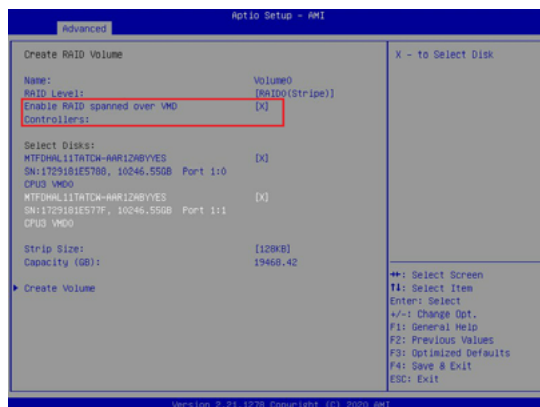

Figure 6-4. Created Volume *with* enabling RAID spanned over VMD Controller

Status Indications

An LED indicator on the drive carrier shows the RAID status of the drive.

Drive Carrier Status LED Indicator	
Status	State (red)
Normal function	Off
Locating	4 Hz blink
Fault	Solid on
Rebuilding	1 Hz Blink

IBPI SFF 8489 Defined Status LED States

Hot Swap Drives

Intel VMD enables hot-plug and hot-unplug for NVMe SSDs, whether from Intel or other manufacturers. Under vSphere ESXi, several steps are necessary to avoid potential stability issues. See the information at link [1] below.

Hot-unplug

1. Prevent devices from being re-detected during rescan:

```
esxcli storage core claiming autoclaim --enabled=false
```

2. Unmount the VMFS volumes on the device. Check [2] for details.
3. Detach the device. Check [3] for details.
4. Physically remove the device.

Hot-plug

- Physically install the device.

ESXi will automatically discover NVMe SSDs, but a manual scan may be required in some cases.

Related Information Links

[1] <https://kb.vmware.com/s/article/2151404>

[2] <https://docs.vmware.com/en/VMware-vSphere/6.5/com.vmware.vsphere.storage.doc/GUID-1B56EF97-F60E-4F21-82A7-8F2A7294604D.html>

[3] <https://docs.vmware.com/en/VMware-vSphere/6.5/com.vmware.vsphere.storage.doc/GUID-F2E75F67-740B-4406-9F0C-A2D99A698F2A.html>

Chapter 7

Troubleshooting and Support

7.1 Information Resources

Website

A great deal of information is available on the Supermicro website, supermicro.com.



Figure 7-1. Supermicro Website

- Specifications for servers and other hardware are available by clicking the menu icon, then selecting the **Products** option.
- The **Support** option offers downloads (manuals, BIOS/BMC, drivers, etc.), FAQs, RMA, warranty, and other service extensions.

Direct Links for the SYS-240P-TNRT System

[SYS-SYS-240P-TNRT](#) specifications page

[X12QCH+-P motherboard page](#) for links to the Quick Reference Guide, User Manual, validated storage drives, etc.

Direct Links for General Support and Information

[Frequently Asked Questions](#)

[Add-on card descriptions](#)

[TPM User Guide](#)

General Memory Configuration Guide: [X12](#)

[SuperDoctor5 Large Deployment Guide](#)

Direct Links (continued)

For validated memory, see our [Product Resources](#) page

[Product Matrices](#) page for links to tables summarizing specs for systems, motherboards, power supplies, riser cards, add-on cards, etc.

[Security Center](#) for recent security notices

[Supermicro Phone and Addresses](#)

7.2 Baseboard Management Controller Interface

The system supports the Baseboard Management interface. BMC is used to provide remote access, monitoring and management. There are several BIOS settings that are related to BMC.

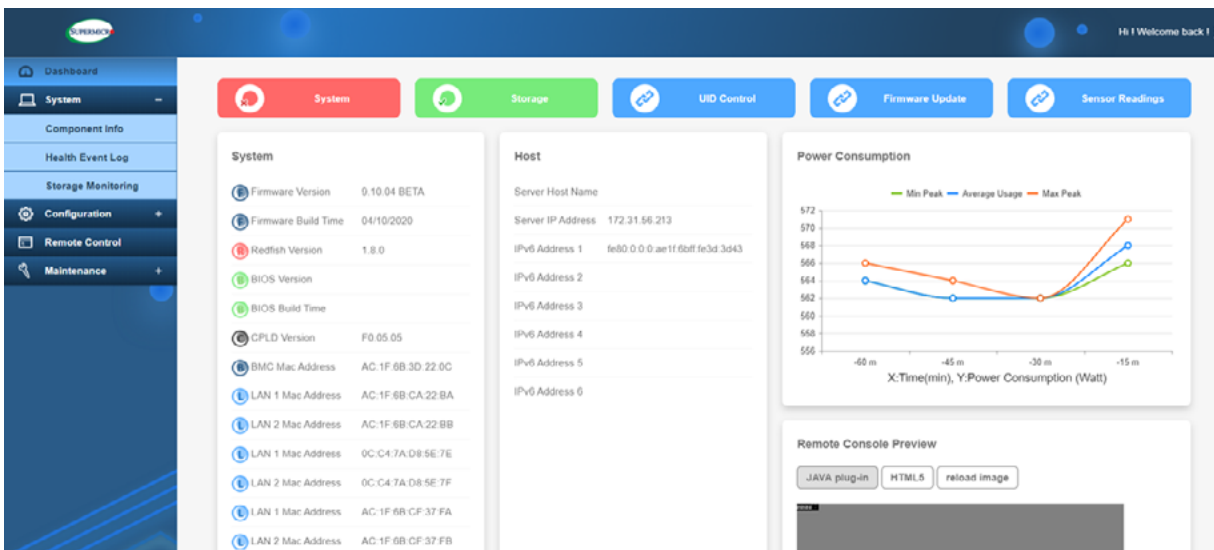

Figure 7-2. BMC Sample

7.3 Troubleshooting Procedures

Use the following procedures to troubleshoot your system. If you have followed all of the procedures below and still need assistance, refer to the [Technical Support Procedures](#) or [Returning Merchandise for Service](#) section(s) in this chapter. [Power down](#) the system before changing any non hot-swap hardware components.

No Power

1. As you try to power up the system, note any beep codes. Refer to the next section for details on [beep codes](#).
2. Check that the power LED on the motherboard is on.

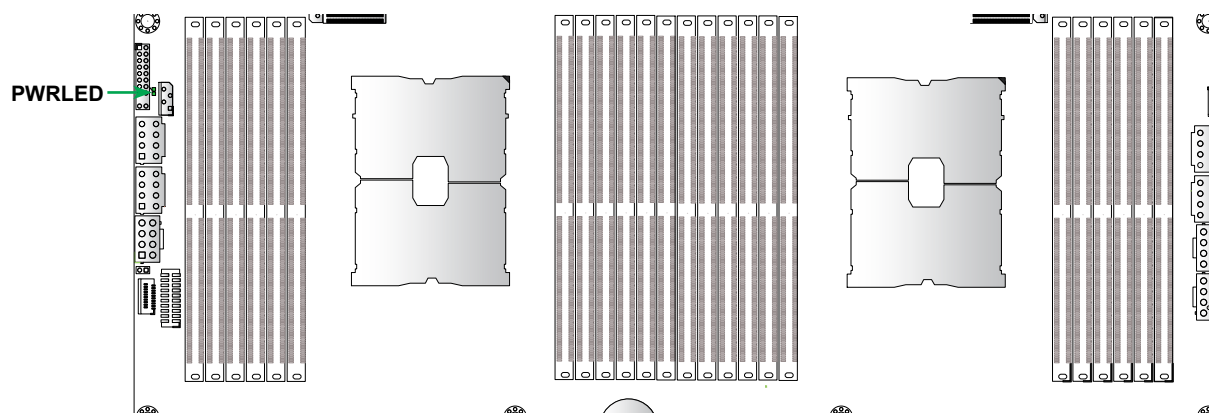

Figure 7-3. Location of the MB Power LED

3. Make sure that the power connector is connected to your power supply.
4. Make sure that no short circuits exist between the motherboard and chassis.
5. Disconnect all cables from the motherboard, including those for the keyboard and mouse.
6. Remove all add-on cards.
7. Install a CPU, a heatsink, connect the internal speaker (if applicable), and the power LED to the motherboard. Make sure that the heatsink is fully seated.
8. Verify that all jumpers are set to their default positions.
9. Check that the power supplies' input voltage operate at 100-120VAC or 180-240VAC.
10. Turn the power switch on and off to test the system

No Video

1. If the power is on but you have no video, remove all the add-on cards and cables.
2. As you try to power up the system, note any beep codes. Refer to the next section for details on [beep codes](#).

System Boot Failure

If the system does not display POST (Power-On-Self-Test) or does not respond after the power is turned on, check the following:

Turn on the system with only one DIMM module installed. If the system boots, check for bad DIMM modules or slots by following the Memory Errors Troubleshooting procedure below.

Memory Errors

1. Make sure that the DIMM modules are properly and fully installed.
2. Confirm that you are using the correct memory. Also, it is recommended that you use the same memory type and speed for all DIMMs in the system. See [Section 3.3](#) for memory details.
3. Check for bad DIMM modules or slots by swapping modules between slots and noting the results.
4. Check the power supply voltage 115V/230V switch.

Losing the System's Setup Configuration

1. Always replace power supplies with the exact same model that came with the system. A poor quality power supply may cause the system to lose the CMOS setup configuration.
2. The battery on your motherboard may be old. Check to verify that it still supplies approximately 3VDC. If it does not, replace it with a new one.
3. If the above steps do not fix the setup configuration problem, contact your vendor for repairs.

When the System Becomes Unstable

If the system becomes unstable during or after OS installation, check the following:

1. CPU/BIOS support: Make sure that your CPU is supported and that you have the latest BIOS installed in your system.

2. Memory support: Make sure that the memory modules are supported by testing the modules using memtest86 or a similar utility.

Note: Refer to the product page on our website at <http://www.supermicro.com> for memory and CPU support and updates.

3. HDD support: Make sure that all hard disk drives (HDDs) work properly. Replace the bad HDDs with good ones.
4. System cooling: Check the system cooling to make sure that all heatsink fans and CPU/system fans, etc., work properly. Check the hardware monitoring settings in the BMC to make sure that the CPU and system temperatures are within the normal range. Also check the front panel Overheat LED and make sure that it is not on.
5. Adequate power supply: Make sure that the power supply provides adequate power to the system. Make sure that all power connectors are connected. Please refer to our website for more information on the minimum power requirements.
6. Proper software support: Make sure that the correct drivers are used.

If the system becomes unstable before or during OS installation, check the following:

1. Source of installation: Make sure that the devices used for installation are working properly, including boot devices such as CD.
2. Cable connection: Check to make sure that all cables are connected and working properly.
3. Using the minimum configuration for troubleshooting: Remove all unnecessary components (starting with add-on cards first), and use the minimum configuration (but with a CPU and a memory module installed) to identify the trouble areas. Refer to the steps listed in Section A above for proper troubleshooting procedures.
4. Identifying bad components by isolating them: If necessary, remove a component in question from the chassis, and test it in isolation to make sure that it works properly. Replace a bad component with a good one.
5. Check and change one component at a time instead of changing several items at the same time. This will help isolate and identify the problem.
6. To find out if a component is good, swap this component with a new one to see if the system will work properly. If so, then the old component is bad. You can also install the component in question in another system. If the new system works, the component is good and the old system has problems.

7.4 BIOS Error Beep (POST) Codes

During the POST (Power-On Self-Test) routines, which are performed each time the system is powered on, errors may occur.

Non-fatal errors are those which, in most cases, allow the system to continue the boot-up process. The error messages normally appear on the screen.

Fatal errors are those which will not allow the system to continue the boot-up procedure. If a fatal error occurs, you should consult with your system manufacturer for possible repairs.

These fatal errors are usually communicated through a series of audible beeps. The table below lists some common errors and their corresponding beep codes encountered by users.

BIOS Error Beep (POST) Codes		
Beep Code	Error Message	Description
1 short	Refresh	Circuits have been reset (Ready to power up)
5 short, 1 long	Memory error	No memory detected in system
5 long, 2 short	Display memory read/write error	Video adapter missing or with faulty memory
1 long continuous	System OH	System overheat condition

Additional BIOS POST Codes

The AMI BIOS supplies additional checkpoint codes, which are documented online at <http://www.supermicro.com/support/manuals/> ("AMI BIOS POST Codes User's Guide").

When BIOS performs the Power On Self Test, it writes checkpoint codes to I/O port 0080h. If the computer cannot complete the boot process, a diagnostic card can be attached to the computer to read I/O port 0080h (Supermicro p/n AOC-LPC80-20).

For information on AMI updates, please refer to <http://www.ami.com/products/>.

7.5 Crash Dump Using BMC

In the event of a processor internal error (IERR) that crashes your system, you may want to provide information to support staff. You can download a crash dump of status information using BMC.

Check BMC Error Log

1. Access the BMC web interface.
2. Click the **Server Health** tab, then **Event Log** to verify an IERR error.

The screenshot shows the BMC web interface. At the top right, there is a 'Host Identification' box containing 'Server: 172.031.040.125' and 'User: ADMIN (Administrator)'. Below this is a navigation bar with tabs: System, Server Health, Configuration, Remote Control, Virtual Media, Maintenance, Miscellaneous, and Help. The 'Server Health' tab is active, and the 'Event Log' sub-tab is selected. On the left, there is a sidebar with 'Server Health', 'Sensor Readings', and 'Event Log' (selected). The main content area shows a message: 'For more special event log settings, please click: [here](#)'. Below this is a text box: 'This page displays events from the system's event log. You can choose a category from the pull-down box to filter the events and also sort them by clicking on a column header.' There are 'Clear Event Log' and 'Save' buttons. A dropdown menu is set to 'All Events'. Below the dropdown is a table with the following data:

Event ID	Time Stamp	Sensor Name	Sensor Type	Description
1	2017/10/19 15:38:37		Processor	IERR - Assertion
2	2017/10/19 15:59:20		Processor	IERR - Assertion

Figure 7-4. BMC Event Log

In the event of an IERR, the BMC executes a crash dump. You must download the crash dump and save it.

7.6 UEFI BIOS Recovery

Warning: Do not upgrade the BIOS unless your system has a BIOS-related issue. Flashing the wrong BIOS can cause irreparable damage to the system. In no event shall Supermicro be liable for direct, indirect, special, incidental, or consequential damages arising from a BIOS update. If you do update the BIOS, do not shut down or reset the system while the BIOS is updating to avoid possible boot failure.

Overview

The Unified Extensible Firmware Interface (UEFI) provides a software-based interface between the operating system and the platform firmware in the pre-boot environment. The UEFI specification supports an architecture-independent mechanism that will allow the UEFI OS loader stored in an add-on card to boot the system. The UEFI offers clean, hands-off management to a computer during system boot.

Recovering the UEFI BIOS Image

A UEFI BIOS flash chip consists of a recovery BIOS block and a main BIOS block (a main BIOS image). The recovery block contains critical BIOS codes, including memory detection and recovery codes for the user to flash a healthy BIOS image if the original main BIOS image is corrupted. When the system power is turned on, the recovery block codes execute first. Once this process is complete, the main BIOS code will continue with system initialization and the remaining POST (Power-On Self-Test) routines.

Note 1: Follow the BIOS recovery instructions below for BIOS recovery when the main BIOS block crashes.

Note 2: When the BIOS recovery block crashes, you will need to follow the procedures to make a Returned Merchandise Authorization (RMA) request. Also, you may use the Supermicro Update Manager (SUM) Out-of-Band (https://www.supermicro.com.tw/products/nfo/SMS_SUM.cfm) to reflash the BIOS.

Recovering the Main BIOS Block with a USB Device

This feature allows the user to recover the main BIOS image using a USB-attached device without additional utilities used. A USB flash device such as a USB Flash Drive, or a USB CD/DVD ROM/RW device can be used for this purpose. However, a USB Hard Disk drive cannot be used for BIOS recovery at this time.

The file system supported by the recovery block is FAT (including FAT12, FAT16, and FAT32) which is installed on a bootable or non-bootable USB-attached device. However, the BIOS might need several minutes to locate the SUPER.ROM file if the media size becomes too large due to the huge volumes of folders and files stored in the device.

To perform UEFI BIOS recovery using a USB-attached device, follow the instructions below.

1. Using a different machine, copy the "Super.ROM" binary image file into the Root "\\" directory of a USB device or a writable CD/DVD.

Note 1: If you cannot locate the "Super.ROM" file in your drive disk, visit our website at www.supermicro.com to download the BIOS package. Extract the BIOS binary image into a USB flash device and rename it "Super.ROM" for the BIOS recovery use.

Note 2: Before recovering the main BIOS image, confirm that the "Super.ROM" binary image file you download is the same version or a close version meant for your motherboard.

2. Insert the USB device that contains the new BIOS image ("Super.ROM") into your USB drive and reset the system when the following screen appears.
3. After locating the healthy BIOS binary image, the system will enter the BIOS Recovery menu as shown below.



Note: At this point, you may decide if you want to start the BIOS recovery. If you decide to proceed with BIOS recovery, follow the procedures below.

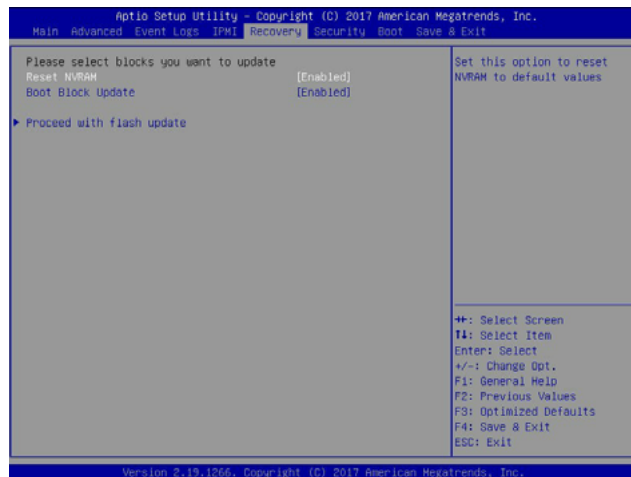

4. When the screen as shown above displays, use the arrow keys to select the item "Proceed with flash update" and press the <Enter> key. You will see the BIOS recovery progress as shown in the screen below.

Note: Do not interrupt the BIOS flashing process until it has completed.

5. After the BIOS recovery process is complete, press any key to reboot the system.
6. Using a different system, extract the BIOS package into a USB flash drive.

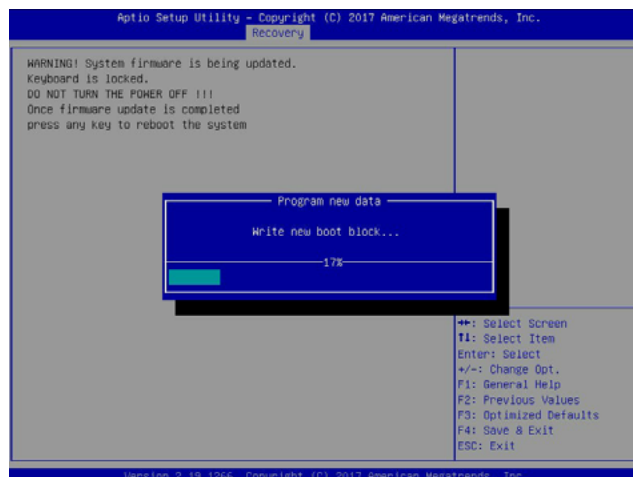

7. Press continuously during system boot to enter the BIOS Setup utility. From the top of the tool bar, select Boot to enter the submenu. From the submenu list, select Boot

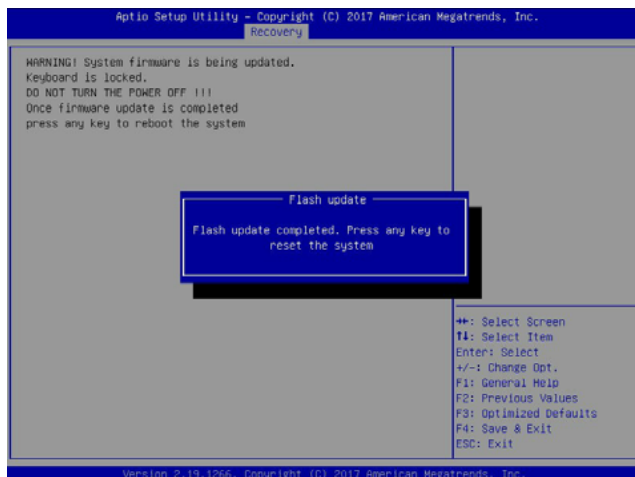

Option #1 as shown below. Then, set Boot Option #1 to [UEFI AP:UEFI: Built-in EFI Shell]. Press <F4> to save the settings and exit the BIOS Setup utility.

8. When the UEFI Shell prompt appears, type fs# to change the device directory path. Go to the directory that contains the BIOS package you extracted earlier from Step 6. Enter flash.nsh BIOSname.### at the prompt to start the BIOS update process.

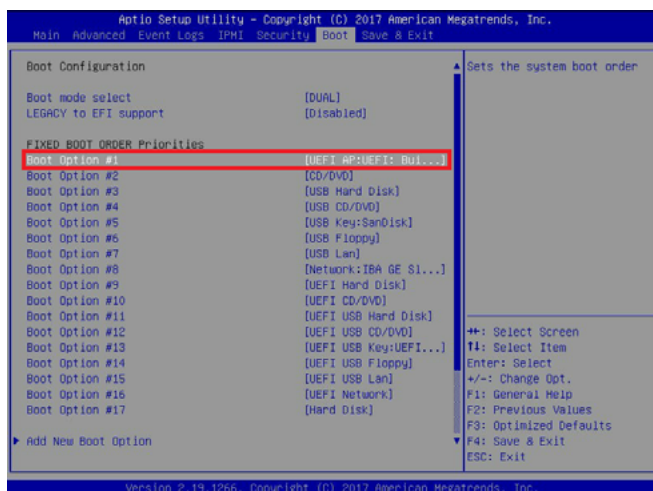

Note: *Do not interrupt this process* until the BIOS flashing is complete.

```
UEFI Interactive Shell v2.1
EDK II
UEFI v2.50 (American Megatrends, 0x0005000C)
Reading table
FS0: Alias(s):HD0:0B;BLK1:
  PciRoot(0x0)/Pci(0x14,0x0)/USB(0x11,0x0)/HD(1,MBR,0x7701D72,0x000,0x1
CR5920)
  BLK0: Alias(s):
    PciRoot(0x0)/Pci(0x14,0x0)/USB(0x11,0x0)
Press F8C in 1 seconds to skip startup.nsh or any other key to continue.
Shell: f8c
FS0:\> cd \AFUD05
FS0:\AFUD05> cd SKJPM2_03162017
FS0:\AFUD05\SKJPM2_03162017> flash.nsh X110P07_314
```

9. The screen above indicates that the BIOS update process is complete. When you see the screen above, unplug the AC power cable from the power supply, clear CMOS, and plug

```
Done.
[ Access Cmos Port Ex ]
<Read>
Index 0x51: 0x1B

Done.
*****
* Program BIOS and ME (including FDT) regions...
*****
|
|  ME Firmware Update Utility v4.09-04-1217
|  Copyright (C)2017 American Megatrends Inc. All Rights Reserved.
|
CPUID = 50652
Reading flash ..... done
- ME Data Size checking - ok
- FFS checksums ..... ok
- Check RomLayout ..... ok
Erasing Boot Block ..... done
Updating Boot Block ..... done
Verifying Boot Block ..... done
Erasing Main Block ..... 0x00132000 (0X)
```

the AC power cable in the power supply again to power on the system.

10. Press continuously to enter the BIOS Setup utility.

```
Verifying NDB Block ..... done
- Update success for FDR
- Update success for IC
- Successful update Recovery Loader to DPRx11
- Successful update MFSB11
- Successful update FTR11
- Successful update MFS, SBI and IUB211
- Successful update FLOG and UTDx11
- ME Entire Image update success !!
WARNING : System must power-off to have the changes take effect!
Moving FS0:\AFUD05\SKJPM2_03162017\fdt\64.efi -> FS0:\AFUD05\SKJPM2_03162017\F
01.sec
- [ok]
Moving FS0:\AFUD05\SKJPM2_03162017\afuef\64.efi -> FS0:\AFUD05\SKJPM2_0316201
7\afuef1.sec
- [ok]
*****
* Please ignore this "Shell: Cannot read from file - Device Error"
* warning message due to it does not inspect flashing process.
*****
Deleting "afuef1.sec"
Delete successful.
FS0:\>
```

11. Press <F3> to load the default settings.
12. After loading the default settings, press <F4> to save the settings and exit the BIOS Setup utility.

7.7 CMOS Clear

JBT1 is used to clear CMOS, which will also clear any passwords. Instead of pins, this jumper consists of contact pads to prevent accidentally clearing the contents of CMOS.

To Clear CMOS

1. First [power down](#) the system completely.
2. [Remove the cover](#) of the chassis to access the motherboard.
3. [Remove the onboard battery](#) from the motherboard.
4. Short the CMOS pads with a metal object such as a small screwdriver for at least four seconds.
5. Remove the screwdriver or shorting device.
6. Replace the cover, reconnect the power cords and power on the system.

Notes: Clearing CMOS will also clear all passwords.

Do not use the PW_ON connector to clear CMOS.



7.8 Where to Get Replacement Components

If you need replacement parts for your system, to ensure the highest level of professional service and technical support, purchase exclusively from our Supermicro Authorized Distributors/System Integrators/Resellers. A list can be found at: <http://www.supermicro.com>. Click the "Where to Buy" tab.

7.9 Reporting an Issue

Technical Support Procedures

Before contacting Technical Support, please take the following steps. If your system was purchased through a distributor or reseller, please contact them for troubleshooting services. They have the best knowledge of your specific system configuration.

1. Please review the [Troubleshooting Procedures](#) in this manual and [Frequently Asked Questions](#) on our website before contacting Technical Support.
2. BIOS upgrades can be downloaded from our website. **Note:** Not all BIOS can be flashed depending on the modifications to the boot block code.
3. If you still cannot resolve the problem, include the following information when contacting us for technical support:
 - System, motherboard, and chassis model numbers and PCB revision number
 - BIOS release date/version (this can be seen on the initial display when your system first boots up)
 - System configuration

An example of a Technical Support form is posted on our [website](#). Distributors: For immediate assistance, please have your account number ready when contacting our technical support department by email.

Returning Merchandise for Service

A receipt or copy of your invoice marked with the date of purchase is required before any warranty service will be rendered. You can obtain service by calling your vendor for a Returned Merchandise Authorization (RMA) number. When returning to the manufacturer, the RMA number should be prominently displayed on the outside of the shipping carton, and mailed prepaid or hand-carried. Shipping and handling charges will be applied for all orders that must be mailed when service is complete.

For faster service, RMA authorizations may be requested online (<http://www.supermicro.com/support/rma/>).

Whenever possible, repack the chassis in the original Supermicro carton, using the original packaging material. If these are no longer available, be sure to pack the chassis securely, using packaging material to surround the chassis so that it does not shift within the carton and become damaged during shipping.

This warranty only covers normal consumer use and does not cover damages incurred in shipping or from failure due to the alteration, misuse, abuse or improper maintenance of products.

During the warranty period, contact your distributor first for any product problems.

Vendor Support Filing System

For issues related to Intel, use the Intel IPS filing system:

<https://www.intel.com/content/www/us/en/design/support/ips/training/welcome.html>

For issues related to Red Hat Enterprise Linux, since it is a subscription based OS, contact your account representative.

7.10 Feedback

Supermicro values your feedback as we strive to improve our customer experience in all facets of our business. Please email us at techwriterteam@supermicro.com to provide feedback on our manuals.

7.11 Contacting Supermicro

Headquarters

Address: Super Micro Computer, Inc.
980 Rock Ave.
San Jose, CA 95131 U.S.A.

Tel: +1 (408) 503-8000

Fax: +1 (408) 503-8008

Email: marketing@supermicro.com (General Information)
Sales-USA@supermicro.com (Sales Inquiries)
Government_Sales-USA@supermicro.com (Gov. Sales Inquiries)
support@supermicro.com (Technical Support)
RMA@supermicro.com (RMA Support)
Webmaster@supermicro.com (Webmaster)

Website: www.supermicro.com

Europe

Address: Super Micro Computer B.V.
Het Sterrenbeeld 28, 5215 ML
's-Hertogenbosch, The Netherlands

Tel: +31 (0) 73-6400390

Fax: +31 (0) 73-6416525

Email: Sales_Europe@supermicro.com (Sales Inquiries)
Support_Europe@supermicro.com (Technical Support)
RMA_Europe@supermicro.com (RMA Support)

Website: www.supermicro.nl

Asia-Pacific

Address: Super Micro Computer, Inc.
3F, No. 150, Jian 1st Rd.
Zhonghe Dist., New Taipei City 235
Taiwan (R.O.C)

Tel: +886-(2) 8226-3990

Fax: +886-(2) 8226-3992

Email: Sales-Asia@supermicro.com.tw (Sales Inquiries)
Support@supermicro.com.tw (Technical Support)
RMA@supermicro.com.tw (RMA Support)

Website: www.supermicro.com.tw

Appendix A

Standardized Warning Statements for AC Systems

About Standardized Warning Statements

The following statements are industry standard warnings, provided to warn the user of situations which have the potential for bodily injury. Should you have questions or experience difficulty, contact Supermicro's Technical Support department for assistance. Only certified technicians should attempt to install or configure components.

Read this appendix in its entirety before installing or configuring components in the Supermicro chassis.

These warnings may also be found on our website at http://www.supermicro.com/about/policies/safety_information.cfm.

Warning Definition



Warning! This warning symbol means danger. You are in a situation that could cause bodily injury. Before you work on any equipment, be aware of the hazards involved with electrical circuitry and be familiar with standard practices for preventing accidents.

警告の定義

この警告サインは危険を意味します。

人身事故につながる可能性がありますので、いずれの機器でも動作させる前に、電気回路に含まれる危険性に注意して、標準的な事故防止策に精通して下さい。

此警告符号代表危險。

您正处于可能受到严重伤害的工作环境中。在您使用设备开始工作之前，必须充分意识到触电的危险，并熟练掌握防止事故发生的标准工作程序。请根据每项警告结尾的声明号码找到此设备的安全性警告说明的翻译文本。

此警告符號代表危險。

您正處於可能身體可能會受損傷的工作環境中。在您使用任何設備之前，請注意觸電的危險，並且要熟悉預防事故發生的標準工作程序。請依照每一注意事項後的號碼找到相關的翻譯說明內容。

Warnung

WICHTIGE SICHERHEITSHINWEISE

Dieses Warnsymbol bedeutet Gefahr. Sie befinden sich in einer Situation, die zu Verletzungen führen kann. Machen Sie sich vor der Arbeit mit Geräten mit den Gefahren elektrischer Schaltungen und den üblichen Verfahren zur Vorbeugung vor Unfällen vertraut. Suchen Sie mit der am Ende jeder Warnung angegebenen Anweisungsnummer nach der jeweiligen Übersetzung in den übersetzten Sicherheitshinweisen, die zusammen mit diesem Gerät ausgeliefert wurden.

BEWAHREN SIE DIESE HINWEISE GUT AUF.

INSTRUCCIONES IMPORTANTES DE SEGURIDAD

Este símbolo de aviso indica peligro. Existe riesgo para su integridad física. Antes de manipular cualquier equipo, considere los riesgos de la corriente eléctrica y familiarícese con los procedimientos estándar de prevención de accidentes. Al final de cada advertencia encontrará el número que le ayudará a encontrar el texto traducido en el apartado de traducciones que acompaña a este dispositivo.

GUARDE ESTAS INSTRUCCIONES.

IMPORTANTES INFORMATIONS DE SÉCURITÉ

Ce symbole d'avertissement indique un danger. Vous vous trouvez dans une situation pouvant entraîner des blessures ou des dommages corporels. Avant de travailler sur un équipement, soyez conscient des dangers liés aux circuits électriques et familiarisez-vous avec les procédures couramment utilisées pour éviter les accidents. Pour prendre connaissance des traductions des avertissements figurant dans les consignes de sécurité traduites qui accompagnent cet appareil, référez-vous au numéro de l'instruction situé à la fin de chaque avertissement.

CONSERVEZ CES INFORMATIONS.

תקנון הזהרות אזהרה

הזהרות הבאות הן אזהרות על פי תקני התעשייה, על מנת להזהיר את המשתמש מפני חבלה פיזית אפשרית. במידה ויש שאלות או היתקלות בבעיה כלשהי, יש ליצור קשר עם מחלקת תמיכה טכנית של סופרמיקרו. טכנאים מוסמכים בלבד רשאים להתקין או להגדיר את הרכיבים. יש לקרוא את הנספח במלואו לפני התקנת או הגדרת הרכיבים במארזי סופרמיקרו.

اَكْ ف حالة وُكِي اَي تتسبب ف اصابة جسدهُ هذا الزهز عُ خطر! تحذُرُ .
 قبل اَي تعول على اَي هعدات، كي على علن بالوخاطز ال اُجوة عي الذوائر
 الكهزبائِة
 وكي على دراةُ بالووارسات النقااِة لو عُ وقع اَي حادث
 استخدم رقن الب اِى الو صُص ف هاةُ كل تحذُرُ للعشر تزجوتها

안전을 위한 주의사항

경고!

이 경고 기호는 위험이 있음을 알려 줍니다. 작업자의 신체에 부상을 야기 할 수 있는 상태에 있게 됩니다. 모든 장비에 대한 작업을 수행하기 전에 전기회로와 관련된 위험요소들을 확인하시고 사전에 사고를 방지할 수 있도록 표준 작업절차를 준수해 주시기 바랍니다.

해당 번역문을 찾기 위해 각 경고의 마지막 부분에 제공된 경고문 번호를 참조하십시오

BELANGRIJKE VEILIGHEIDSINSTRUCTIES

Dit waarschuwings symbool betekent gevaar. U verkeert in een situatie die lichamelijk letsel kan veroorzaken. Voordat u aan enige apparatuur gaat werken, dient u zich bewust te zijn van de bij een elektrische installatie betrokken risico's en dient u op de hoogte te zijn van de standaard procedures om ongelukken te voorkomen. Gebruik de nummers aan het eind van elke waarschuwing om deze te herleiden naar de desbetreffende locatie.

BEWAAR DEZE INSTRUCTIES

Installation Instructions



Warning! Read the installation instructions before connecting the system to the power source.

設置手順書

システムを電源に接続する前に、設置手順書をお読み下さい。

警告

将此系统连接电源前,请先阅读安装说明。

警告

將系統與電源連接前，請先閱讀安裝說明。

Warnung

Vor dem Anschließen des Systems an die Stromquelle die Installationsanweisungen lesen.

¡Advertencia!

Lea las instrucciones de instalación antes de conectar el sistema a la red de alimentación.

Attention

Avant de brancher le système sur la source d'alimentation, consulter les directives d'installation.

יש לקרוא את הוראות התקנה לפני חיבור המערכת למקור מתח.

اقرأ إرشادات التركيب قبل توصيل النظام إلى مصدر للطاقة

시스템을 전원에 연결하기 전에 설치 안내를 읽어주십시오.

Waarschuwing

Raadpleeg de installatie-instructies voordat u het systeem op de voedingsbron aansluit.

Circuit Breaker

Warning! This product relies on the building's installation for short-circuit (overcurrent) protection. Ensure that the protective device is rated not greater than: 250 V, 20 A.

サーキット・ブレーカー

この製品は、短絡(過電流)保護装置がある建物での設置を前提としています。

保護装置の定格が250 V、20 Aを超えないことを確認下さい。

警告

此产品的短路(过载电流)保护由建筑物的供电系统提供,确保短路保护设备的额定电流不大于250V,20A。

警告

此產品的短路(過載電流)保護由建築物的供電系統提供,確保短路保護設備的額定電流不大於250V,20A。

Warnung

Dieses Produkt ist darauf angewiesen, dass im Gebäude ein Kurzschluss- bzw. Überstromschutz installiert ist. Stellen Sie sicher, dass der Nennwert der Schutzvorrichtung nicht mehr als: 250 V, 20 A beträgt.

¡Advertencia!

Este equipo utiliza el sistema de protección contra cortocircuitos (o sobrecorrientes) del edificio. Asegúrese de que el dispositivo de protección no sea superior a: 250 V, 20 A.

Attention

Pour ce qui est de la protection contre les courts-circuits (surtension), ce produit dépend de l'installation électrique du local. Vérifiez que le courant nominal du dispositif de protection n'est pas supérieur à :250 V, 20 A.

מוצר זה מסתמך על הגנה המותקנת במבנים למניעת קצר חשמלי. יש לוודא כי המכשיר המגן מפני הקצר החשמלי הוא לא יותר מ-250VDC, 20A

هذا المنتج يعتمد على معدات الحماية مه الدوائر القصيرة التي تم تثبيتها في المبنى
تأكد من أن تقييم الجهاز الوقائي ليس أكثر من : 20A, 250V

경고!

이 제품은 전원의 단락(과전류)방지에 대해서 전적으로 건물의 관련 설비에 의존합니다. 보호장치의 정격이 반드시 250V(볼트), 20A(암페어)를 초과하지 않도록 해야 합니다.

Waarschuwing

Dit product is afhankelijk van de kortsluitbeveiliging (overspanning) van uw elektrische installatie. Controleer of het beveiligde apparaat niet groter gedimensioneerd is dan 250V, 20A.

Power Disconnection Warning



Warning! The system must be disconnected from all sources of power and the power cord removed from the power supply module(s) before accessing the chassis interior to install or remove system components.



電源切断の警告

システムコンポーネントの取り付けまたは取り外しのために、シャーシ内部にアクセスするには、システムの電源はすべてのソースから切断され、電源コードは電源モジュールから取り外す必要があります。

警告

在你打开机箱并安装或移除内部器件前,必须将系统完全断电,并移除电源线。

警告

在您打開機殼安裝或移除內部元件前，必須將系統完全斷電，並移除電源線。

Warnung

Das System muss von allen Quellen der Energie und vom Netzanschlusskabel getrennt sein, das von den Spg.Versorgungsteilmodulen entfernt wird, bevor es auf den Chassisinnenraum zurückgreift, um Systemsbestandteile anzubringen oder zu entfernen.

¡Advertencia!

El sistema debe ser disconnected de todas las fuentes de energía y del cable eléctrico quitado de los módulos de fuente de alimentación antes de tener acceso el interior del chasis para instalar o para quitar componentes de sistema.

Attention

Le système doit être débranché de toutes les sources de puissance ainsi que de son cordon d'alimentation secteur avant d'accéder à l'intérieur du chassis pour installer ou enlever des composants de système.

אזהרה מפני ניתוק חשמלי

אזהרה!

יש לנתק את המערכת מכל מקורות החשמל ויש להסיר את כבל החשמלי מהספק לפני גישה לחלק הפנימי של המארז לצורך התקנת או הסרת רכיבים.

يجب فصل انظاؤ من جميع مصادر انطاقت وإزانت سهك انكهرباء من وحدة امداد انطاقت قېم

انصل إلى امناطق انداخييت نههيكم نثبيج أو إزانت مكناث الجهاز

경고!

시스템에 부품들을 장착하거나 제거하기 위해서는 새시 내부에 접근하기 전에 반드시 전원 공급장치로부터 연결되어있는 모든 전원과 전기코드를 분리해주어야 합니다.

Waarschuwing

Voordat u toegang neemt tot het binnenwerk van de behuizing voor het installeren of verwijderen van systeem onderdelen, dient u alle spanningsbronnen en alle stroomkabels aangesloten op de voeding(en) van de behuizing te verwijderen

Equipment Installation



Warning! Only trained and qualified personnel should be allowed to install, replace, or service this equipment.

機器の設置

トレーニングを受け認定された人だけがこの装置の設置、交換、またはサービスを許可されていません。

警告

只有经过培训且具有资格的人员才能进行此设备的安装、更换和维修。

警告

只有經過受訓且具資格人員才可安裝、更換與維修此設備。

Warnung

Das Installieren, Ersetzen oder Bedienen dieser Ausrüstung sollte nur geschultem, qualifiziertem Personal gestattet werden.

¡Advertencia!

Solamente el personal calificado debe instalar, reemplazar o utilizar este equipo.

Attention

Il est vivement recommandé de confier l'installation, le remplacement et la maintenance de ces équipements à des personnels qualifiés et expérimentés.

אזהרה!

צוות מוסמך בלבד רשאי להתקין, להחליף את הציוד או לתת שירות עבור הציוד.

والمدربيه لتزكيب واستبدال أو خدمة هذا الجهاز يجب أن يسمح فقط للمظفيه المؤهليه

경고!

훈련을 받고 공인된 기술자만이 이 장비의 설치, 교체 또는 서비스를 수행할 수 있습니다.

Waarschuwing

Deze apparatuur mag alleen worden geïnstalleerd, vervangen of hersteld door geschoold en gekwalificeerd personeel.

Restricted Area

Warning! This unit is intended for installation in restricted access areas. A restricted access area can be accessed only through the use of a special tool, lock and key, or other means of security. (This warning does not apply to workstations).

アクセス制限区域

このユニットは、アクセス制限区域に設置されることを想定しています。

アクセス制限区域は、特別なツール、鍵と錠前、その他のセキュリティの手段を用いてのみ出入りが可能です。

警告

此部件应安装在限制进出的场所，限制进出的场所指只能通过使用特殊工具、锁和钥匙或其它安全手段进出的场所。

警告

此装置仅限安装於進出管制區域，進出管制區域係指僅能以特殊工具、鎖頭及鑰匙或其他安全方式才能進入的區域。

Warnung

Diese Einheit ist zur Installation in Bereichen mit beschränktem Zutritt vorgesehen. Der Zutritt zu derartigen Bereichen ist nur mit einem Spezialwerkzeug, Schloss und Schlüssel oder einer sonstigen Sicherheitsvorkehrung möglich.

¡Advertencia!

Esta unidad ha sido diseñada para instalación en áreas de acceso restringido. Sólo puede obtenerse acceso a una de estas áreas mediante la utilización de una herramienta especial, cerradura con llave u otro medio de seguridad.

Attention

Cet appareil doit être installé dans des zones d'accès réservés. L'accès à une zone d'accès réservé n'est possible qu'en utilisant un outil spécial, un mécanisme de verrouillage et une clé, ou tout autre moyen de sécurité.

אזור עם גישה מוגבלת

אזהרה!

יש להתקין את היחידה באזורים שיש בהם הגבלת גישה. הגישה ניתנת בעזרת 'כלי אבטחה בלבד' (מפתח, מנעול וכד.).

تخصيص هذه انحدة نترك بُها ف مناطق محظورة تم .

،ممكن اننصل إن منطقت محظورة فقط من خلال استخذاو أداة خاصت أو أ وس هُت أخري نلالأمما ققم ومفتاح

경고!

이 장치는 접근이 제한된 구역에 설치하도록 되어있습니다. 특수도구, 잠금 장치 및 키, 또는 기타 보안 수단을 통해서만 접근 제한 구역에 들어갈 수 있습니다.

Waarschuwing

Dit apparaat is bedoeld voor installatie in gebieden met een beperkte toegang. Toegang tot dergelijke gebieden kunnen alleen verkregen worden door gebruik te maken van speciaal gereedschap, slot en sleutel of andere veiligheidsmaatregelen.

Battery Handling



Warning! There is the danger of explosion if the battery is replaced incorrectly. Replace the battery only with the same or equivalent type recommended by the manufacturer. Dispose of used batteries according to the manufacturer's instructions

電池の取り扱い

電池交換が正しく行われなかった場合、破裂の危険性があります。交換する電池はメーカーが推奨する型、または同等のものを使用下さい。使用済電池は製造元の指示に従って処分して下さい。

警告

電池更換不當會有爆炸危險。請只使用同類電池或制造商推荐的功能相当的電池更換原有電池。請按制造商的說明處理廢舊電池。

警告

電池更換不當會有爆炸危險。請使用製造商建議之相同或功能相當的電池更換原有電池。請按照製造商的說明指示處理廢棄舊電池。

Warnung

Bei Einsetzen einer falschen Batterie besteht Explosionsgefahr. Ersetzen Sie die Batterie nur durch den gleichen oder vom Hersteller empfohlenen Batterietyp. Entsorgen Sie die benutzten Batterien nach den Anweisungen des Herstellers.

Attention

Danger d'explosion si la pile n'est pas remplacée correctement. Ne la remplacer que par une pile de type semblable ou équivalent, recommandée par le fabricant. Jeter les piles usagées conformément aux instructions du fabricant.

¡Advertencia!

Existe peligro de explosión si la batería se reemplaza de manera incorrecta. Reemplazar la batería exclusivamente con el mismo tipo o el equivalente recomendado por el fabricante. Desechar las baterías gastadas según las instrucciones del fabricante.

אזהרה!

קיימת סכנת פיצוץ של הסוללה במידה והוחלפה בדרך לא תקינה. יש להחליף את הסוללה בסוג התואם מחברת יצרן מומלצת. סילוק הסוללות המשומשות יש לבצע לפי הוראות היצרן.

هناك خطر من انفجار في حالة اسبدال البطارية بطريقة غير صحيحة فعلى
اسبدال البطارية
فقط بنفس النوع أو ما يعادلها مما أوصت به الشركة المصنعة
جخلص من البطاريات المسحومة وفقا لعمليات الشركة الصانعة

경고!

배터리가 올바르게 교체되지 않으면 폭발의 위험이 있습니다. 기존 배터리와 동일하거나 제조사에서 권장하는 동등한 종류의 배터리로만 교체해야 합니다. 제조사의 안내에 따라 사용된 배터리를 처리하여 주십시오.

Waarschuwing

Er is ontplofingsgevaar indien de batterij verkeerd vervangen wordt. Vervang de batterij slechts met hetzelfde of een equivalent type die door de fabrikant aanbevolen wordt. Gebruikte batterijen dienen overeenkomstig fabrieksvoorschriften afgevoerd te worden.

Redundant Power Supplies



Warning! This unit might have more than one power supply connection. All connections must be removed to de-energize the unit.

冗長電源装置

このユニットは複数の電源装置が接続されている場合があります。

ユニットの電源を切るためには、すべての接続を取り外さなければなりません。

警告

此部件连接的电源可能不止一个，必须将所有电源断开才能停止给该部件供电。

警告

此装置连接的电源可能不只一个，必须切断所有电源才能停止对该装置的供电。

Warnung

Dieses Gerät kann mehr als eine Stromzufuhr haben. Um sicherzustellen, dass der Einheit kein Strom zugeführt wird, müssen alle Verbindungen entfernt werden.

¡Advertencia!

Puede que esta unidad tenga más de una conexión para fuentes de alimentación. Para cortar por completo el suministro de energía, deben desconectarse todas las conexiones.

Attention

Cette unité peut avoir plus d'une connexion d'alimentation. Pour supprimer toute tension et tout courant électrique de l'unité, toutes les connexions d'alimentation doivent être débranchées.

אם קיים יותר מספק אחד

אזהרה!

ליחידה יש יותר מחיבור אחד של ספק. יש להסיר את כל החיבורים על מנת לרוקן את היחידה.

قد يكون لهذا الجهاز عدة اتصالات بوحدات امداد الطاقة .

يجب إزالة كافة الاتصالات لعسل الوحدة عن الكهرباء

경고!

이 장치에는 한 개 이상의 전원 공급 단자가 연결되어 있을 수 있습니다. 이 장치에 전원을 차단하기 위해서는 모든 연결 단자를 제거해야만 합니다.

Waarschuwing

Deze eenheid kan meer dan één stroomtoevoeraansluiting bevatten. Alle aansluitingen dienen verwijderd te worden om het apparaat stroomloos te maken.

Backplane Voltage



Warning! Hazardous voltage or energy is present on the backplane when the system is operating. Use caution when servicing.

バックプレーンの電圧

システムの稼働中は危険な電圧または電力が、バックプレーン上にかかっています。

修理する際には注意ください。

警告

当系统正在进行时，背板上有很危险的电压或能量，进行维修时务必小心。

警告

當系統正在進行時，背板上危險的電壓或能量，進行維修時務必小心。

Warnung

Wenn das System in Betrieb ist, treten auf der Rückwandplatine gefährliche Spannungen oder Energien auf. Vorsicht bei der Wartung.

¡Advertencia!

Cuando el sistema está en funcionamiento, el voltaje del plano trasero es peligroso. Tenga cuidado cuando lo revise.

Attention

Lorsque le système est en fonctionnement, des tensions électriques circulent sur le fond de panier. Prendre des précautions lors de la maintenance.

מתח בפנל האחורי

אזהרה!

קיימת סכנת מתח בפנל האחורי בזמן תפעול המערכת. יש להיזהר במהלך העבודה.

هناك خطر من التيار الكهربائي أو الطاقة المتجددة على اللوحة
عندما يكون النظام يعمل كه حذرا عند خدمة هذا الجهاز

경고!

시스템이 동작 중일 때 후면판 (Backplane)에는 위험한 전압이나 에너지가 발생 합니다.
서비스 작업 시 주의하십시오.

Waarschuwing

Een gevaarlijke spanning of energie is aanwezig op de backplane wanneer het systeem in gebruik is. Voorzichtigheid is geboden tijdens het onderhoud.

Comply with Local and National Electrical Codes



Warning! Installation of the equipment must comply with local and national electrical codes.

地方および国の電気規格に準拠

機器の取り付けはその地方および国の電気規格に準拠する必要があります。

警告

设备安装必须符合本地与本国电气法规。

警告

設備安裝必須符合本地與本國電氣法規。

Warnung

Die Installation der Geräte muss den Sicherheitsstandards entsprechen.

¡Advertencia!

La instalación del equipo debe cumplir con las normas de electricidad locales y nacionales.

Attention

L'équipement doit être installé conformément aux normes électriques nationales et locales.

תיאום חוקי החשמל הארצי
אזהרה!
התקנת הציוד חייבת להיות תואמת לחוקי החשמל המקומיים והארציים.

تركيب المعدات الكهربائية يجب أن يمتثل للقوايه المحلية والبطية المتعلقة
بالكهرباء

경고!

현 지역 및 국가의 전기 규정에 따라 장비를 설치해야 합니다.

Waarschuwing

Bij installatie van de apparatuur moet worden voldaan aan de lokale en nationale elektriciteitsvoorschriften.

Product Disposal



Warning! Ultimate disposal of this product should be handled according to all national laws and regulations.

製品の廃棄

この製品を廃棄処分する場合、国の関係する全ての法律・条例に従い処理する必要があります。

警告

本产品的废弃处理应根据所有国家的法律和规章进行。

警告

本產品的廢棄處理應根據所有國家的法律和規章進行。

Warnung

Die Entsorgung dieses Produkts sollte gemäß allen Bestimmungen und Gesetzen des Landes erfolgen.

¡Advertencia!

Al deshacerse por completo de este producto debe seguir todas las leyes y reglamentos nacionales.

Attention

La mise au rebut ou le recyclage de ce produit sont généralement soumis à des lois et/ou directives de respect de l'environnement. Renseignez-vous auprès de l'organisme compétent.

סילוק המוצר

אזהרה!

סילוק סופי של מוצר זה חייב להיות בהתאם להנחיות וחוקי המדינה.

التخلص النهائي من هذا المنتج ينبغي التعامل معه وفقا لجميع القوانين واللوائح الوطنية عند

경고!

이 제품은 해당 국가의 관련 법규 및 규정에 따라 폐기되어야 합니다.

Waarschuwing

De uiteindelijke verwijdering van dit product dient te geschieden in overeenstemming met alle nationale wetten en reglementen.

Hot Swap Fan Warning



Warning! Hazardous moving parts. Keep away from moving fan blades. The fans might still be turning when you remove the fan assembly from the chassis. Keep fingers, screwdrivers, and other objects away from the openings in the fan assembly's housing.

ファン・ホットスワップの警告

警告!回転部品に注意。運転中は回転部(羽根)に触れないでください。シャーシから冷却ファン装置を取り外した際、ファンがまだ回転している可能性があります。ファンの開口部に、指、ドライバー、およびその他のものを近づけないで下さい。

警告!

警告! 危險的可移動性零件。請務必與轉動的风扇叶片保持距離。當您從機架移除風扇裝置，風扇可能仍在轉動。小心不要將手指、螺絲起子和其他物品太靠近風扇

警告

危險的可移動性零件。請務必與轉動的风扇叶片保持距離。當您從機架移除風扇裝置，風扇可能仍在轉動。小心不要將手指、螺絲起子和其他物品太靠近風扇。

Warnung

Gefährlich Bewegende Teile. Von den bewegenden Lüfterblätter fern halten. Die Lüfter drehen sich u. U. noch, wenn die Lüfterbaugruppe aus dem Chassis genommen wird. Halten Sie Finger, Schraubendreher und andere Gegenstände von den Öffnungen des Lüftergehäuses entfernt.

¡Advertencia!

Riesgo de piezas móviles. Mantener alejado de las aspas del ventilador. Los ventiladores podran dar vuelta cuando usted quite el montaje del ventilador del chasis. Mantenga los dedos, los destornilladores y todos los objetos lejos de las aberturas del ventilador

Attention

Pieces mobiles dangereuses. Se tenir a l'écart des lames du ventilateur Il est possible que les ventilateurs soient toujours en rotation lorsque vous retirerez le bloc ventilateur du châssis. Prenez garde à ce que doigts, tournevis et autres objets soient éloignés du logement du bloc ventilateur.

אזהרה!

חלקים נעים מסוכנים. התרחק מלהבי המאוורר בפעולה כאשר מסירים את חלקי המאוורר מהמארז, יתכן והמאווררים עדיין עובדים. יש להרחיק למרחק בטוח את האצבעות וכלי עבודה שונים מהפתחים בתוך המאוורר

تحذير! أجزاء متحركة خطيرة. ابتعد عن شفرات المروحة المتحركة. من الممكن أن المراوح لا تزال تدور عند إزالة كتلة المروحة من الهيكل يجب إبقاء الأصابع ومفكات البراغي وغيرها من الأشياء بعيدا عن الفتحات في كتلة المروحة

경고!

움직이는 위험한 부품. 회전하는 송풍 날개에 접근하지 마세요. 새시로부터 팬 조립품을 제거할 때 팬은 여전히 회전하고 있을 수 있습니다. 팬 조립품 외관의 열려있는 부분들로부터 손가락 및 스크류드라이버, 다른 물체들이 가까이 하지 않도록 배치해 주십시오.

Waarschuwing

Gevaarlijk bewegende onderdelen. Houd voldoende afstand tot de bewegende ventilatorbladen. Het is mogelijk dat de ventilator nog draait tijdens het verwijderen van het ventilatorsamenstel uit het chassis. Houd uw vingers, schroevendraaiers en eventuele andere voorwerpen uit de buurt van de openingen in de ventilatorbehuizing.

Power Cable and AC Adapter



Warning! When installing the product, use the provided or designated connection cables, power cables and AC adapters. Using any other cables and adapters could cause a malfunction or a fire. Electrical Appliance and Material Safety Law prohibits the use of UL or CSA -certified cables (that have UL/CSA shown on the cord) for any other electrical devices than products designated by Supermicro only.

電源コードとACアダプター

製品を設置する場合、提供または指定および購入された接続ケーブル、電源コードとACアダプターを該当する地域の条例や安全基準に適合するコードサイズやプラグと共に使用下さい。他のケーブルやアダプタを使用すると故障や火災の原因になることがあります。

電気用品安全法は、ULまたはCSA認定のケーブル(UL/CSAマークがコードに表記)を Supermicro が指定する製品以外に使用することを禁止しています。

警告

安装此产品时,请使用本身提供的或指定的或采购的连接线,电源线和电源适配器。包含遵照当地法规和安全要求的合规的电源线尺寸和插头。使用其它线材或适配器可能会引起故障或火灾。除了Supermicro所指定的产品,电气用品和材料安全法律规定禁止使用未经UL或CSA认证的线材。(线材上会显示UL/CSA符号)。

警告

安裝此產品時,請使用本身提供的或指定的或採購的連接線,電源線和電源適配器。包含遵照當地法規和安全要求的合規的電源線尺寸和插頭。使用其它線材或適配器可能會引起故障或火災。除了Supermicro所指定的產品,電氣用品和材料安全法律規定禁止使用未經UL或CSA認證的線材。(線材上會顯示UL/CSA符號)。

Warnung

Nutzen Sie beim Installieren des Produkts ausschließlich die von uns zur Verfügung gestellten Verbindungskabeln, Stromkabeln und/oder Adapter, die Ihre örtlichen Sicherheitsstandards einhalten. Der Gebrauch von anderen Kabeln und Adapter können Fehlfunktionen oder Feuer verursachen. Die Richtlinien untersagen das Nutzen von UL oder CAS zertifizierten Kabeln (mit UL/CSA gekennzeichnet), an Geräten oder Produkten die nicht mit Supermicro gekennzeichnet sind.

¡Advertencia!

Cuando instale el producto, utilice la conexión provista o designada o procure cables, Cables de alimentación y adaptadores de CA que cumplan con los códigos locales y los requisitos de seguridad, incluyendo el tamaño adecuado del cable y el enchufe. El uso de otros cables y adaptadores podría causar un mal funcionamiento o un incendio. La Ley de Seguridad de Aparatos Eléctricos y de Materiales prohíbe El uso de cables certificados por UL o CSA (que tienen el certificado UL / CSA en el código) para cualquier otros dispositivos eléctricos que los productos designados únicamente por Supermicro.

Attention

Lors de l'installation du produit, utilisez les cables de connection fournis ou désigné ou achetez des cables, cables de puissance et adaptateurs respectant les normes locales et les conditions de securite y compris les tailles de cables et les prises electriques appropries. L'utilisation d'autres cables et adaptateurs peut provoquer un dysfonctionnement ou un incendie. Appareils électroménagers et la Loi sur la Sécurité Matériel interdit l'utilisation de câbles certifiés- UL ou CSA (qui ont UL ou CSA indiqué sur le code) pour tous les autres appareils électriques sauf les produits désignés par Supermicro seulement.

AC ימאתמו מיי למשח מילבכ

!הרהזא

ךרוצל ומאתוה וא ושכרנ רשא AC מיימאתמו מיקפס, מילבכב שמתשהל שי, רצומה תא מיניקתמ רשאכ לכב שומיש . עקתהו לבכה לש הנוכח הדימ ללוכ, תוימוקמה תוחיטבה תושירדל ומאתוה רשאו, הנקתהה למשחה ירישכמב שומישה יקוחל מאתהב. ילמשח רצק וא הלקתל מורגל לולע, רחא גוסמ מאתמ וא לבכ לש דוק מהילע עיפומ רשאכ) UL-ב או CSA-ב -ב מיכמומה מילבכב שמתשהל רוסיא מייק, תוחיטבה יקוחו דבלב Supermicro י"ע מאתוה רשא רצומב קר אלא, רחא ילמשח רצומ לכ רובע (UL/CSA)

תאלבאלא אארשב מץ וא אדדחמלא וא ארפוטמלא תאליטוטלא מאדחטסאב מץ, אגתנמלא בייקרת דנע לכלז יפ אמב אילחמלא אלאסלא תאבלטתמו נינאווקב מאזתלאלא אמ דדרתמלא ראיטלא תאלוחמו אילברמלא קיירח וא לטע יפ בבסטטי דץ ירשא תאלוחמו תאלבאלא יא מאדחטסא. מילסלא סבאלאו לטומוא מץ ח CSA וא UL לביק נמ אדמאמלא תאלבאלא מאדחטסא תאדמלא אילברמלא אזהאלל אלאסלא נונאק רזחי Supermicro לביק נמ אדדחמלא אילברמלא תאגתנמלא רייג ירשא תאדמא יא אמ (UL/CSA) אלאמלא לטחתיטלאו

전원 케이블 및 AC 어댑터

경고! 제품을 설치할 때 현지 코드 및 적절한 굵기의 코드와 플러그를 포함한 안전 요구 사항을 준수하여 제공되거나 지정된 연결 혹은 구매 케이블, 전원 케이블 및 AC 어댑터를 사용하십시오.

다른 케이블이나 어댑터를 사용하면 오작동이나 화재가 발생할 수 있습니다. 전기 용품 안전법은 UL 또는 CSA 인증 케이블 (코드에 UL / CSA가 표시된 케이블)을 Supermicro 가 지정한 제품 이외의 전기 장치에 사용하는 것을 금지합니다.

Stroomkabel en AC-Adapter

Waarschuwing! Bij het aansluiten van het Product uitsluitend gebruik maken van de geleverde Kabels of een andere geschikte aan te schaffen Aansluitmethode, deze moet altijd voldoen aan de lokale voorschriften en veiligheidsnormen, inclusief de juiste kabeldikte en stekker. Het gebruik van niet geschikte Kabels en/of Adapters kan een storing of brand veroorzaken. Wetgeving voor Elektrische apparatuur en Materiaalveiligheid verbied het gebruik van UL of CSA -gecertificeerde Kabels (met UL/CSA in de code) voor elke andere toepassing dan de door Supermicro hiervoor beoogde Producten.

Appendix B

System Specifications

Processors

3rd Generation Intel® Xeon® Scalable processors in an LGA4189 socket; UPI up to 10.4GT/s; supports CPU TDP up to 250W

Note: Refer to the motherboard specifications pages on our website for updates to supported processors.

Chipset

Intel® C621

BIOS

AMI 128Mb SPI Flash EEPROM

Memory

48 DIMM slots for up to 12TB 3DS ECC DDR4-3200:RDIMM/LRDIMM or 18TB Intel® Optane™ DDR4-2666:DCPMM, RDIMM/LRDIMM/DCPMM

Storage Drives

24 hot-swap 2.5" NVMe/SAS3/SATA3 drive bays

Four optional rear 2.5" bays SAS/SATA

Two M.2 NVMe/SATA3

PCI Expansion Slots

Up to 6 single-wide PCIe 3.0 (4 x16 + 2 x8) slots

-or-

Up to 2 double-wide PCIe 3.0 x16 slots for GPUs

Input/Output

Network: Two 10G BaseT with Intel X710-TM4; 2x 10G SFP+ with Intel X710-TM4, and (optional) AIOM up to 100G QSFP 28

BMC: Dedicated LAN port

USB: Two rear USB 3.0 ports, one USB 3.0 Type A header

Video: One VGA port

COM: One serial port header

Motherboard

X12QCH+-P; Length 17.0", width 16.8" (431.8 mm x 426.7 mm)

Chassis

CSE-218HTS-R2K08P; 2U Rackmount, 3.5 x 17.3 x 31.6in. / 89 x 439.5 x 803mm (HxWxD)

System Cooling

Four 8-cm heavy duty fans

Power Supply

Model: PWS-2K08A-1R, Titanium Level Power Supply (80 Plus)

AC Input Voltages: 100-240 VAC auto-range

Rated Input Current: 100-127Vac / 12-9A / 50-60Hz

200-220Vac / 10-9.8A / 50-60Hz

220-230Vac / 10-9.8A / 50-60Hz

230-240Vac / 10-9.8A / 50-60Hz

220-240Vac / 11-10A / 50-60Hz (UL only)

Rated Input Frequency: 50-60 Hz

Rated Output Power: 1000W: 100 – 127Vac

1800W: 200 – 220Vac

1980W: 220 – 230Vac

2000W: 230 – 240Vac

2000W: 220 – 240Vac (UL only)

Rated Output Voltages: 12V+

Max: 83A / Min: 0A (at 1000W)

Max: 150A / Min: 0A (at 1500W)

Max: 165A / Min: 0A (at 1980W)

Max: 166A / Min: 0A (at 2000W)

Max: 166A / Min: 0A (at 2000W, China only)

12Vsb: Max: 3.5A / Min: 0A

Operating Environment

Operating Temperature: 10° to 35° C (50° to 95° F)

Non-operating Temperature: -40° to 60° C (-40° to 140° F)

Operating Relative Humidity: 8% to 90% (non-condensing)

Non-operating Relative Humidity: 5% to 95% (non-condensing)

Regulatory Compliance

FCC, ICES, CE, VCCI, RCM, UKCA, NRTL, CB

Applied Directives, Standards

EMC/EMI: 2014/30/EU (EMC Directive)

FCC Part 15 Subpart B

ICES-003

VCCI-CISPR 32

AS/NZS CISPR 32

EN/BS EN55032

EN/BS EN55035

CISPR 32

CISPR 35

EN/BS 61000-3-2

EN/BS 61000-3-3

EN/BS 61000-4-2

EN/BS 61000-4-3

EN/BS 61000-4-4

EN/BS 61000-4-5

EN/BS 61000-4-6

EN/BS 61000-4-8

EN/BS 61000-4-11

Green Environment:

2011/65/EU (RoHS Directive)

EC 1907/2006 (REACH)

2012/19/EU (WEEE Directive)

California Proposition 65

Product Safety: 2014/35/EU (LVD Directive)

UL/CSA 60950-1 2nd Edition

UL/CSA 62368-1 (USA and Canada)

IEC/EN 62368-1

IEC 60950-1 2nd Edition

Perchlorate Warning

California Best Management Practices Regulations for Perchlorate Materials: This Perchlorate warning applies only to products containing CR (Manganese Dioxide) Lithium coin cells. "Perchlorate Material-special handling may apply. See www.dtsc.ca.gov/hazardouswaste/perchlorate"

この装置は、クラスA機器です。この装置を住宅環境で使用すると電波妨害を引き起こすことがあります。この場合には使用者が適切な対策を講ずるよう要求されることがあります。

VCCI – A

Appendix C

BSMI Chinese Safety Warnings

限用物質含有情況標示聲明書

Declaration of the Presence Condition of the Restricted Substances Marking

設備名稱: 伺服器/ Server Equipment name 型號 (型式): 218H-R20X12 Type designation (Type) (系列型號:): SYS-240P-TNRT, 218H-20, 218H-MP4						
單元 Unit	Restricted substances and its chemical symbols 限用物質及其化學符號					
	鉛 Lead (Pb)	汞 Mercury (Hg)	鎘 Cadmium (Cd)	六價鉻 Hexavalent chromium (Cr ⁺⁶)	多溴聯苯 Polybrominated biphenyls (PBB)	多溴二苯醚 Polybrominated diphenyl ethers (PBDE)
機殼 (Chassis)	○	○	○	○	○	○
機殼風扇 (Chassis Fan)	-	○	○	○	○	○
線材 (Cable)	○	○	○	○	○	○
主機板 (Motherboard)	-	○	○	○	○	○
電源供應器 (Power Supply)	-	○	○	○	○	○
硬碟 (HDD, M.2)	-	○	○	○	○	○
電源背板 (PDB)	-	○	○	○	○	○
附加卡 (Add-on Card)	-	○	○	○	○	○
<p>備考1. “超出0.1 wt %”及“超出0.01 wt %”係指限用物質之百分比含量超出百分比含量基準值。</p> <p>Note 1 : “Exceeding 0.1 wt %” and “exceeding 0.01 wt %” indicate that the percentage content of the restricted substance exceeds the reference percentage value of presence condition.</p> <p>備考2. “○”係指該項限用物質之百分比含量未超出百分比含量基準值。備考3. “-”係指該項限用物質為排除項目。</p> <p>Note 2 : “○” indicates that the percentage content of the restricted substance does not exceed the percentage of reference value of presence.</p> <p>Note 3 : The “-” indicates that the restricted substance corresponds to the exemption.</p>						

輸入額定:

100-127V~, 60-50Hz, 12-9A

200-240V~, 60-50Hz, 10-9.8A

***使用者不能任意拆除或替換內部配備**

***報驗義務人之姓名或名稱: 美超微電腦股份有限公司**

警告使用者：

此為甲類資訊技術設備，於居住環境中使用時，可能會造成射頻擾動，在此種情況下，使用者會被要求採取某些適當的對策。