



OPEN

Industry Standard, Flexible Architecture

GREEN

Less Heat, Less Power Consumption

STABLE

Robust Design, Quality Parts

Stable and
Reliable Solution

Server/Workstation

Motherboard

GNRD8-2L2T

User Manual

English



Version 1.70

Published Mar. 2026

Copyright©2026 ASRock Rack Inc. All rights reserved.

Copyright Notice:

No part of this documentation may be reproduced, transcribed, transmitted, or translated in any language, in any form or by any means, except duplication of documentation by the purchaser for backup purpose, without written consent of ASRock Rack Inc.

Products and corporate names appearing in this documentation may or may not be registered trademarks or copyrights of their respective companies, and are used only for identification or explanation and to the owners' benefit, without intent to infringe.

Disclaimer:

Specifications and information contained in this documentation are furnished for informational use only and subject to change without notice, and should not be constructed as a commitment by ASRock Rack. ASRock Rack assumes no responsibility for any errors or omissions that may appear in this documentation.

With respect to the contents of this documentation, ASRock Rack does not provide warranty of any kind, either expressed or implied, including but not limited to the implied warranties or conditions of merchantability or fitness for a particular purpose.

In no event shall ASRock Rack, its directors, officers, employees, or agents be liable for any indirect, special, incidental, or consequential damages (including damages for loss of profits, loss of business, loss of data, interruption of business and the like), even if ASRock Rack has been advised of the possibility of such damages arising from any defect or error in the documentation or product.



WARNING

THIS PRODUCT CONTAINS A BUTTON BATTERY

If swallowed, a button battery can cause serious injury or death.

Please keep batteries out of sight or reach of children

ASRock Rack's Website: www.ASRockRack.com

INTEL END USER SOFTWARE LICENSE AGREEMENT
IMPORTANT - READ BEFORE COPYING, INSTALLING OR USING.

LICENSE. Licensee has a license under Intel's copyrights to reproduce Intel's Software only in its unmodified and binary form, (with the accompanying documentation, the "Software") for Licensee's personal use only, and not commercial use, in connection with Intel-based products for which the Software has been provided, subject to the following conditions:

- (a) Licensee may not disclose, distribute or transfer any part of the Software, and You agree to prevent unauthorized copying of the Software.
- (b) Licensee may not reverse engineer, decompile, or disassemble the Software.
- (c) Licensee may not sublicense the Software.
- (d) The Software may contain the software and other intellectual property of third party suppliers, some of which may be identified in, and licensed in accordance with, an enclosed license.txt file or other text or file.
- (e) Intel has no obligation to provide any support, technical assistance or updates for the Software.

OWNERSHIP OF SOFTWARE AND COPYRIGHTS. Title to all copies of the Software remains with Intel or its licensors or suppliers. The Software is copyrighted and protected by the laws of the United States and other countries, and international treaty provisions. Licensee may not remove any copyright notices from the Software. Except as otherwise expressly provided above, Intel grants no express or implied right under Intel patents, copyrights, trademarks, or other intellectual property rights. Transfer of the license terminates Licensee's right to use the Software.

DISCLAIMER OF WARRANTY. The Software is provided "AS IS" without warranty of any kind, EITHER EXPRESS OR IMPLIED, INCLUDING WITHOUT LIMITATION, WARRANTIES OF MERCHANTABILITY OR FITNESS FOR ANY PARTICULAR PURPOSE.

LIMITATION OF LIABILITY. NEITHER INTEL NOR ITS LICENSORS OR SUPPLIERS WILL BE LIABLE FOR ANY LOSS OF PROFITS, LOSS OF USE, INTERRUPTION OF BUSINESS, OR INDIRECT, SPECIAL, INCIDENTAL, OR CONSEQUENTIAL DAMAGES OF ANY KIND WHETHER UNDER THIS AGREEMENT OR OTHERWISE, EVEN IF INTEL HAS BEEN ADVISED OF THE POSSIBILITY OF SUCH DAMAGES.

LICENSE TO USE COMMENTS AND SUGGESTIONS. This Agreement does NOT obligate Licensee to provide Intel with comments or suggestions regarding the Software. However, if Licensee provides Intel with comments or suggestions for the modification, correction, improvement or enhancement of (a) the Software or (b) Intel products or processes that work with the Software, Licensee grants to Intel a non-exclusive, worldwide, perpetual, irrevocable, transferable, royalty-free license, with the right to sublicense, under Licensee's intellectual property rights, to incorporate or otherwise utilize those comments and suggestions.

TERMINATION OF THIS LICENSE. Intel or the sublicensor may terminate this license at any time if Licensee is in breach of any of its terms or conditions. Upon termination, Licensee will immediately destroy or return to Intel all copies of the Software.

THIRD PARTY BENEFICIARY. Intel is an intended beneficiary of the End User License Agreement and has the right to enforce all of its terms.

U.S. GOVERNMENT RESTRICTED RIGHTS. The Software is a commercial item (as defined in 48 C.F.R. 2.101) consisting of commercial computer software and commercial computer software documentation (as those terms are used in 48 C.F.R. 12.212), consistent with 48 C.F.R. 12.212 and 48 C.F.R. 227.7202-1 through 227.7202-4. You will not provide the Software to the U.S. Government. Contractor or Manufacturer is Intel Corporation, 2200 Mission College Blvd., Santa Clara, CA 95054.

EXPORT LAWS. Licensee agrees that neither Licensee nor Licensee's subsidiaries will export/re-export the Software, directly or indirectly, to any country for which the U.S. Department of Commerce or any other agency or department of the U.S. Government or the foreign government from where it is shipping requires an export license, or other governmental approval, without first obtaining any such required license or approval. In the event the Software is exported from the U.S.A. or re-exported from a foreign destination by Licensee, Licensee will ensure that the distribution and export/re-export or import of the Software complies with all laws, regulations, orders, or other restrictions of the U.S. Export Administration Regulations and the appropriate foreign government.

APPLICABLE LAWS. This Agreement and any dispute arising out of or relating to it will be governed by the laws of the U.S.A. and Delaware, without regard to conflict of laws principles. The Parties to this Agreement exclude the application of the United Nations Convention on Contracts for the International Sale of Goods (1980). The state and federal courts sitting in Delaware, U.S.A. will have exclusive jurisdiction over any dispute arising out of or relating to this Agreement. The Parties consent to personal jurisdiction and venue in those courts. A Party that obtains a judgment against the other Party in the courts identified in this section may enforce that judgment in any court that has jurisdiction over the Parties.

CALIFORNIA, USA ONLY

The Lithium battery adopted on this motherboard contains Perchlorate, a toxic substance controlled in Perchlorate Best Management Practices (BMP) regulations passed by the California Legislature. When you discard the Lithium battery in California, USA, please follow the related regulations in advance.

"Perchlorate Material-special handling may apply, see www.dtsc.ca.gov/hazardouswaste/perchlorate"

AUSTRALIA ONLY

Our goods come with guarantees that cannot be excluded under the Australian Consumer Law. You are entitled to a replacement or refund for a major failure and compensation for any other reasonably foreseeable loss or damage caused by our goods. You are also entitled to have the goods repaired or replaced if the goods fail to be of acceptable quality and the failure does not amount to a major failure. If you require assistance please call ASRock Rack Tel : +886-2-55599600 ext.123 (Standard International call charges apply)

Licensee's specific rights may vary from country to country.



This device complies with Part 15 of the FCC Rules. Operation is subject to the following two conditions:

- (1) this device may not cause harmful interference, and
- (2) this device must accept any interference received, including interference that may cause undesired operation.

This equipment has been tested and found to comply with the limits for a Class B digital device, pursuant to part 15 of the FCC Rules. These limits are designed to provide reasonable protection against harmful interference in a residential installation. This equipment generates, uses and can radiate radio frequency energy and, if not installed and used in accordance with the instructions, may cause harmful interference to radio communications. However, there is no guarantee that interference will not occur in a particular installation. If this equipment does cause harmful interference to radio or television reception, which can be determined by turning the equipment off and on, the user is encouraged to try to correct the interference by one or more of the following measures:

- Reorient or relocate the receiving antenna.
- Increase the separation between the equipment and receiver.
- Connect the equipment into an outlet on a circuit different from that to which the receiver is connected.
- Consult the dealer or an experienced radio/TV technician for help.



ASRock Rack INC. hereby declares that this device is in compliance with the essential requirements and other relevant provisions of related Directives. Full text of EU declaration of conformity is available at: <http://www.asrockrack.com>

ASRock Rack follows the green design concept to design and manufacture our products, and makes sure that each stage of the product life cycle of ASRock Rack product is in line with global environmental regulations. In addition, ASRock Rack disclose the relevant information based on regulation requirements.

Please refer to <https://www.asrockrack.com/general/about.asp?cat=Responsibility> for information disclosure based on regulation requirements ASRock Rack is complied with.



ASRock Rack INC. hereby declares that this device is in compliance with the essential requirements and other relevant provisions of related UKCA Directives. Full text of UKCA declaration of conformity is available at: <http://www.asrockrack.com>



DO NOT throw the motherboard in municipal waste. This product has been designed to enable proper reuse of parts and recycling. This symbol of the crossed out wheeled bin indicates that the product (electrical and electronic equipment) should not be placed in municipal waste. Check local regulations for disposal of electronic products.

Contents

Chapter 1 Introduction	1
1.1 Package Contents	1
1.2 Specifications	2
1.3 Unique Features	5
1.4 Motherboard Layout	6
1.5 Onboard LED Indicators	9
1.6 I/O Panel	11
1.7 Block Diagram	13
Chapter 2 Installation	14
2.1 Screw Holes	14
2.2 Pre-installation Precautions	15
2.3 Installing the CPU and Heatsink	16
2.4 Installing the Memory Modules (DIMM)	22
2.5 Expansion Slots (PCI Express Slots)	24
2.6 Onboard Headers and Connectors	25
2.7 Unit Identification purpose LED/Switch	32
2.8 Dr. Debug	33
2.9 Dual LAN and Teaming Operation Guide	39
2.10 M.2_SSD Module Installation Guide	40
Chapter 3 UEFI Setup Utility	42
3.1 Introduction	42
3.1.1 UEFI Menu Bar	42
3.1.2 Navigation Keys	43

3.2	Main Screen	44
3.2.1	Mother Board Information	45
3.2.2	Processor Information	45
3.2.3	Memory Information	46
3.3	Advanced Screen	47
3.3.1	CPU Configuration	48
3.3.2	Platform Power Configuration	50
3.3.3	DRAM Configuration	52
3.3.4	Chipset Configuration	54
3.3.5	NVMe Configuration	56
3.3.6	ACPI Configuration	57
3.3.7	USB Configuration	58
3.3.8	Serial Port Console Redirection	59
3.3.9	H/W Monitor	62
3.3.10	Network Stack Configuration	63
3.3.11	Intel VMD technology	65
3.3.12	Driver Health	66
3.3.13	Tls Auth Configuration	67
3.3.14	Instant Flash	68
3.4	Server Mgmt	69
3.4.1	BMC Network Configuration	71
3.4.2	DNS Configuration	73
3.4.3	System Event Log	74
3.4.4	BMC Tools	75

3.5	Event Logs	76
3.6	Security	77
3.6.1	Expert Key Management	78
3.7	Boot Screen	82
3.8	Exit Screen	84
Chapter 4 Software Support		85
4.1	Download and Install Operating System	85
4.2	Download and Install Software Drivers	85
Chapter 5 Troubleshooting		86
5.1	Troubleshooting Procedures	86
5.2	Technical Support Procedures	88
5.3	Returning Merchandise for Service	88
Contact Information		89

Chapter 1 Introduction

Thank you for purchasing ASRock Rack **GNRD8-2L2T** motherboard, a reliable motherboard produced under ASRock Rack's consistently stringent quality control. It delivers excellent performance with robust design conforming to ASRock Rack's commitment to quality and endurance.

In this manual, chapter 1 and 2 contains introduction of the motherboard and step-by-step guide to the hardware installation. Chapter 3 and 4 contains the configuration guide to BIOS setup and information of the software support.



Because the motherboard specifications and the BIOS software might be updated, the content of this manual will be subject to change without notice. In case any modifications of this manual occur, the updated version will be available on ASRock Rack website without further notice. Find the latest memory and CPU support lists on ASRock Rack website as well. ASRock Rack's Website: www.ASRockRack.com

*Please visit the website for specific information and technical support:
<http://www.asrockrack.com/support/>*

1.1 Package Contents

- ASRock Rack GNRD8-2L2T motherboard
(CEB form factor: 10.5" x 12", 26.7 cm x 30.5 cm)
- Quick installation guide
- 1 I/O shield
- 2 Screws for M.2 sockets
- 2 CPU non-fabric carriers (1xE2A, 1xE2B)



If any items are missing or appear damaged, contact the authorized dealer.

1.2 Specifications

GNRD8-2L2T	
Physical Status	
Form Factor	CEB
Dimension	10.5" x 12"(26.7 cm x 30.5 cm)
Processor System	
CPU	Supports Intel® Xeon® 6700P-series, 6500P-series, and 6700E-series processors
Socket	1 Socket E2 (LGA 4710)
Chipset	System on Chip
System Memory	
DIMM Quantity	8 DIMM slots (1DPC)
Type	DDR5 RDIMM DDR5 MRDIMM (1DPC only)
Max. Capacity per DIMM	RDIMM: 128 GB MRDIMM: 64 GB
Max. DIMM Frequency	RDIMM: 6400 MT/s MRDIMM: 8000 MT/s
Voltage	1.1V
<i>Note: Memory capacity, frequency, and voltage support is to be validated.</i>	
PCIe Expansion Slots (SLOT7 close to CPU)	
PCIe x16	SLOT7: PCIe 5.0 / CXL 2.0 x16*
	SLOT6: PCIe 5.0 / CXL 2.0 x16
	SLOT5: PCIe 5.0 / CXL 2.0 x16
	SLOT4: PCIe 5.0 / CXL 2.0 x16*
	SLOT3: PCIe 5.0 / CXL 2.0 x16
	SLOT2: PCIe 5.0 / CXL 2.0 x16*
	SLOT1: PCIe 5.0 / CXL 2.0 x16
<i>*SLOT7, 4, 2 only function with selected processors.</i>	
Other PCIe Expansion Connectors	
M.2	2 M-key (PCIe 5.0 x4), supports 22110 / 2280 form factor
Others	1 MCIO (PCIe 5.0 / CXL 2.0 x8)
Ethernet	
Additional GbE Controller	2 RJ45 (10 GbE) by Intel® X710-AT2 2 RJ45 (1 GbE) by Intel® i210
Server Management	
BMC Controller	ASPEED AST2600: IPMI 2.0 with iKVM and vMedia support
Dedicated IPMI LAN	1 RJ45 dedicated IPMI LAN port by Realtek RTL8211F
Graphics	
Controller	ASPEED AST2600: 1 DB15 (VGA)

Rear I/O	
UID Button / LED	1 UID button w/ LED
Video Output	1 DB15 (VGA)
USB Port	2 Type-A (USB 3.2 Gen1)
LAN Port	2 RJ45 (10 GbE), 2 RJ45 (1 GbE), 1 dedicated IPMI
Internal Connectors/Headers	
Power Connector	1 (24-pin, ATX PSU signal), 4 (8-pin, ATX 12V)
Auxiliary Panel Header	1 (18-pin): chassis intrusion, system fault LED, LAN activity LEDs, locate, SMBus
System Panel Header	1 (9-pin): power switch, reset switch, system power LED, HDD activity LED
VROC Header	1
COM Header	1
NMI Header	1
Fan Header	8 (6-pin)
TPM Header	1 (13-pin, SPI)
Front LAN LED Header	1
HSBP	1
SMBus Header	2
PMBus Header	1
IPMB	1
Clear CMOS	1 (contact pads)
USB Header	1 (19-pin, 1 USB 3.2 Gen1/1 USB 2.0)
Others	1 SDC slot
LED Indicators	
Standby Power LED	1 (5VSB)
80 Debug Port LED	1
Fan Fail LED	8
BMC Heartbeat LED	1
System BIOS	
Type	AMI UEFI BIOS; 512Mb SPI Flash ROM
Features	Plug and Play, ACPI 4.0 (and above) compliance wake-up events, SMBIOS 3.4 and above, ASRock Rack Instant Flash
Hardware Monitor	
Temperature	CPU, MB, Card side, M.2, RAM temperature sensing
Fan	Fan tachometer CPU quiet fan (allow chassis fan speed auto-adjust by CPU temperature) Fan multi-speed control

Voltage	1.8V_PCH, +BAT, PVNN_PCH, 3.3V, 5V, 12V, 3.3VSB, 5VSB, +12VSB
Support OS	
OS	<p>Microsoft® Windows®</p> <ul style="list-style-type: none"> - Server 2022 (64 bit) <p>Linux®</p> <ul style="list-style-type: none"> - Red Hat Enterprise Linux Server 9.4 (64 bit) - SUSE Enterprise Linux Server 15 SP6 (64 bit) - Ubuntu 24.04 (64 bit) <p><i>*Please refer to the website for the latest OS support list.</i></p>
Environment	
Temperature	<p>Operating temperature: 10°C ~ 35°C</p> <p>Non-operating temperature: -40°C ~ 70°C</p>
Humidity	Non-operating humidity: 20% ~ 90% (non-condensing)

NOTE: Please refer to the website for the latest specifications.



This motherboard supports Wake from on Board LAN. To use this function, please make sure that the "Wake on Magic Packet from power off state" is enabled in Device Manager > Intel® Ethernet Connection > Power Management. And the "PCI Devices Power On" is enabled in UEFI SETUP UTILITY > Advanced > ACPI Configuration. After that, onboard LAN1&2 can wake up S5 under OS.



If installing Intel® LAN utility or Marvell SATA utility, this motherboard may fail Windows® Hardware Quality Lab (WHQL) certification tests. If installing the drivers only, it will pass the WHQL tests.

1.3 Unique Features

ASRock Rack Instant Flash is a BIOS flash utility embedded in Flash ROM. This convenient BIOS update tool allows user to update system BIOS without entering operating systems first like MS-DOS or Windows. With this utility, press the <F6> key during the POST or the <F2> key to enter into the BIOS setup menu to access ASRock Rack Instant Flash. Just launch this tool and save the new BIOS file to the USB flash drive, floppy disk or hard drive, then update the BIOS only in a few clicks without preparing an additional floppy diskette or other complicated flash utility. Please be noted that the USB flash drive or hard drive must use FAT32/16/12 file system.

No.	Description
1	Backplane PCI Express Hot-Plug Connector (CPU0_HSBP1)
2	PWM Configuration Header (PWM_CFG1)
3	ATX 12V Power Connector (ATX12V4)
4	2 DDR5 DIMM Slots (DDR5_E1, DDR5_G1)*
5	2 DDR5 DIMM Slots (DDR5_F1, DDR5_H1)*
6	PSU SMBus (PSU_SMB1)
7	System Fan Header (FAN1)
8	ATX Power Connector (ATXPWR1)
9	ATX 12V Power Connector (ATX12V1)
10	ATX 12V Power Connector (ATX12V2)
11	System Fan Header (FAN2)
12	Socket E2 (LGA 4710) (CPU0)
13	ATX 12V Power Connector (ATX12V3)
14	2 DDR5 DIMM Slots (DDR5_A1, DDR5_C1)*
15	USB 3.2 Gen1 Header (USB3_1_1)
16	Mini Cool Edge IO Connector (MCIO1)
17	2 DDR5 DIMM Slots (DDR5_B1, DDR5_D1)*
18	M.2 Socket (M2_2) (Type 2280 / 22110)
19	M.2 Socket (M2_1) (Type 2280 / 22110)
20	Battery
21	MicroSD Card Slot (SDC1)
22	System Fan Header (FAN6)
23	System Fan Header (FAN3)
24	System Fan Header (FAN7)
25	System Fan Header (FAN4)
26	System Fan Header (FAN8)
27	System Fan Header (FAN5)
28	Virtual RAID On CPU Header (RAID_1)
29	System Panel Header (PANEL1)
30	Auxiliary Panel Header (AUX_PANEL1)
31	Clear CMOS Pad (CLRMOSE1)
32	Front LAN LED Connector (LED_LAN_3_4)
33	COM Port Header (COM1)
34	Non Maskable Interrupt Button (NMI_BTN1)

No.	Description
35	BMC SMBus Header (BMC_SMB_2)
36	BMC SMBus Header (BMC_SMB_1)
37	Intelligent Platform Management Bus Header (IPMB_1)
38	SPI TPM Header (TPM1)
39	PCI Express 5.0/CXL 2.0 x16 Slot (PCIE1)
40	PCI Express 5.0/CXL 2.0 x16 Slot (PCIE2)
41	PCI Express 5.0/CXL 2.0 x16 Slot (PCIE3)
42	PCI Express 5.0/CXL 2.0 x16 Slot (PCIE4)
43	PCI Express 5.0/CXL 2.0 x16 Slot (PCIE5)
44	PCI Express 5.0/CXL 2.0 x16 Slot (PCIE6)
45	PCI Express 5.0/CXL 2.0 x16 Slot (PCIE7)

**For DIMM installation and configuration instructions, please see p.22 (Installing the Memory Modules (DIMM)) for more details.*

1.5 Onboard LED Indicators

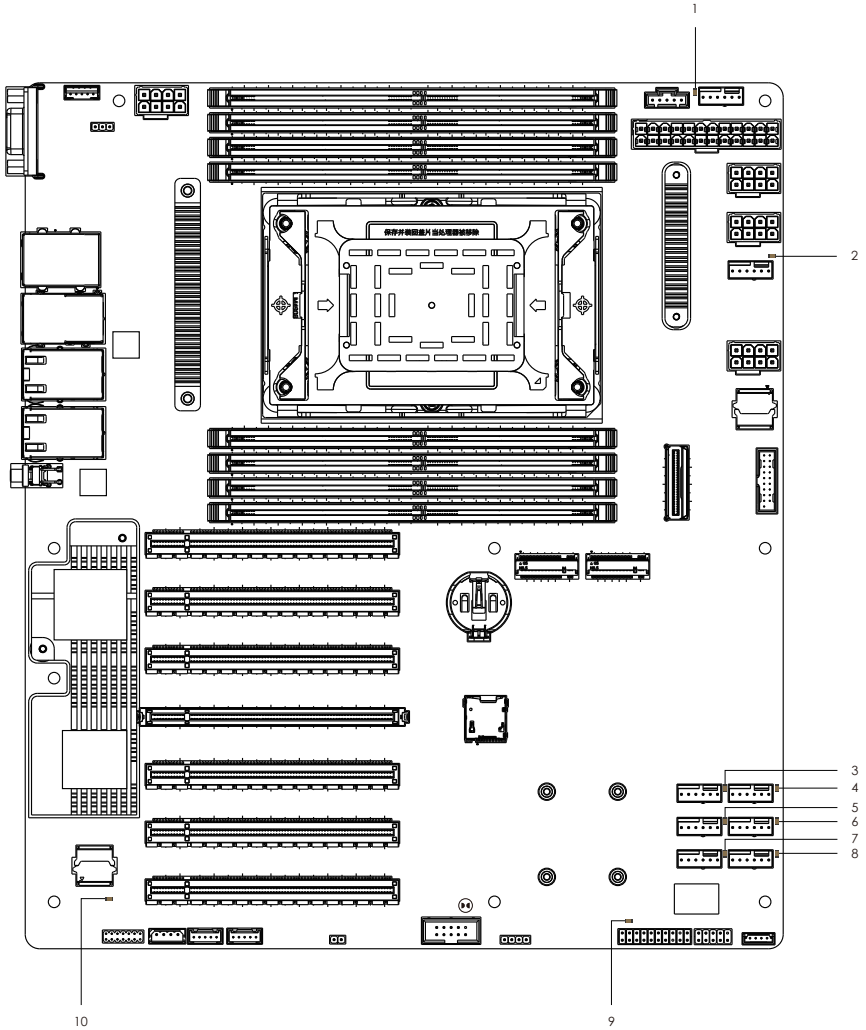

No.	Item	Status	Description
1	FAN_LED1	Red	FAN1 failed
2	FAN_LED2	Red	FAN2 failed
3	FAN_LED6	Red	FAN6 failed
4	FAN_LED3	Red	FAN3 failed
5	FAN_LED7	Red	FAN7 failed
6	FAN_LED4	Red	FAN4 failed
7	FAN_LED8	Red	FAN8 failed
8	FAN_LED5	Red	FAN5 failed
9	SB_PWR1	Green	STB PWR ready
10	BLED1	Blinking four times and then off	Start initialization after AC power-on or BMC reset
		Blinking at 1Hz	BMC ready
		Steady on	Error
		Steady off Other frequency	(The actual behavior depends on the state at the time of failure)

1.6 I/O Panel

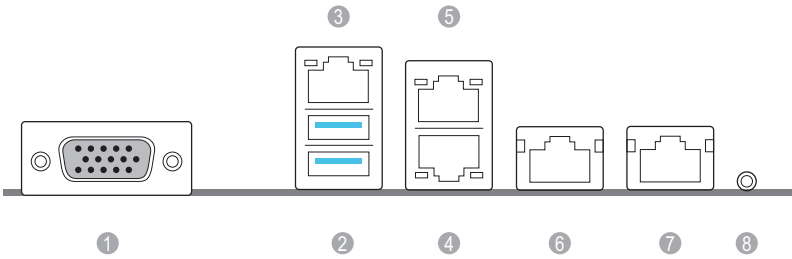

No.	Description	No.	Description
1	VGA Port (VGA1)	5	1G LAN RJ-45 Port (LAN1_2)**
2	USB 3.2 Gen1 Ports (USB3_1_2)	6	10G LAN RJ-45 Port (LAN1, shared NIC)***
3	LAN RJ-45 Port (IPMI_LAN)*	7	10G LAN RJ-45 Port (LAN2)***
4	1G LAN RJ-45 Port (LAN1_2)**	8	UID Switch (UID1)

LAN Port LED Indications

*There are two LEDs on the IPMI LAN port specified for activity and speed. Please refer to the table below for the LAN port LED indications.

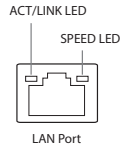

IPMI LAN Port LED Indications

Activity / Link LED		Speed LED	
Status	Description	Status	Description
Off	No link	Off	10 Mbps connection or no link
Blinking Yellow	Data activity	Orange	100 Mbps connection
On	Link	Green	1 Gbps connection

**There are two LEDs on the 1G LAN port specified for activity and speed. Please refer to the table below for the LAN port LED indications.

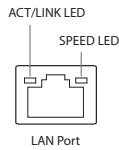

1G LAN Port LED Indications

Activity / Link LED		Speed LED	
Status	Description	Status	Description
Off	No link	Off	10 Mbps connection or no link
Blinking Green	Data activity	Yellow	100 Mbps connection
On	Link	Green	1 Gbps connection

***There are two LEDs on the 10G LAN port specified for activity and speed. Please refer to the table below for the LAN port LED indications.

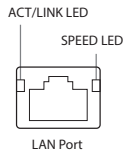

10G LAN Port LED Indications

Activity / Link LED		Speed LED	
Status	Description	Status	Description
Off	No link	Off	100 Mbps connection or no link
Blinking Green	Data activity	Yellow	1 Gbps connection
On	Link	Green	10 Gbps connection

1.7 Block Diagram

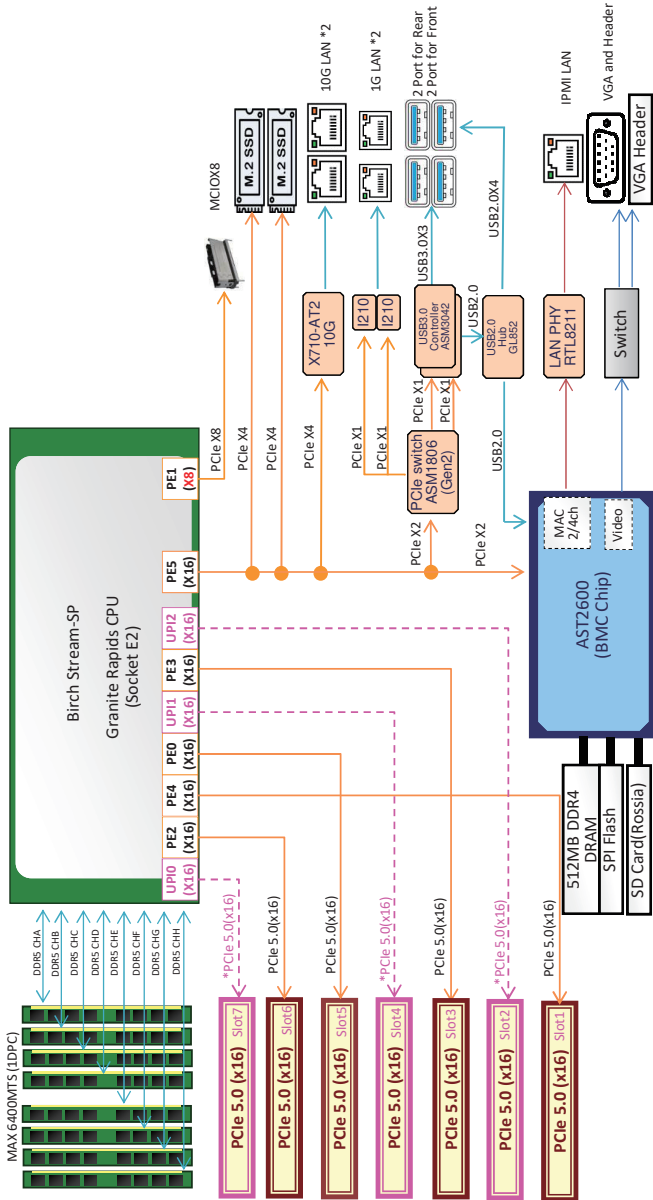

* Only functions with selected processors.
 Selected CPUs: Intel® Xeon® 6781P, 6761P, 6741P, 6731P, 6521P, 6511P

Chapter 2 Installation

This is a Deep Micro-ATX form factor (10.5" x12", 26.7 cm x 30.5 cm) motherboard. Before installing the motherboard, study the configuration of the chassis to ensure that the motherboard fits into it.



1. Ensure the motherboard battery is installed before unplugging the power cord or installing/removing the motherboard.
2. Before installing or removing any component, ensure that the power supply is off or the power cord is detached from the power supply. Failure to do so may cause severe damage to the motherboard, peripherals, and/or components.

2.1 Screw Holes

Place screws into the holes indicated by circles to secure the motherboard to the chassis.



Attention! Before installing this motherboard, be sure to unscrew and remove the standoff at the marked location, under the motherboard, from the chassis, in order to avoid electrical short circuit and motherboard damages.

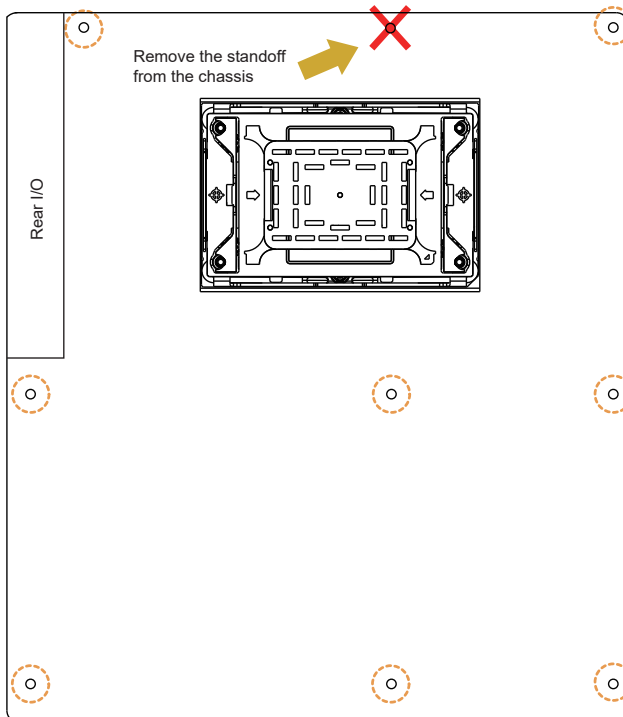



Do not over-tighten the screws! Doing so may damage the motherboard.

2.2 Pre-installation Precautions

Take note of the following precautions before installing motherboard components or change any motherboard settings.

1. Unplug the power cord from the wall socket before touching any components.
2. To avoid damaging the motherboard's components due to static electricity, NEVER place the motherboard directly on the carpet or the like. Also remember to use a grounded wrist strap or touch a safety grounded object before handling the components.
3. Hold components by the edges and do not touch the ICs.
4. Whenever uninstall any component, place it on a grounded anti-static pad or in the bag that comes with the component.
5. When placing screws into the screw holes to secure the motherboard to the chassis, please do not over-tighten the screws! Doing so may damage the motherboard.

2.3 Installing the CPU and Heatsink



1. Unplug all power cables before installing the CPU.
2. Illustration in this documentation are examples only.

Carrier Used

Carrier Type	Xeon® SP XCC	Xeon® SP HCC/LCC/HDCC
Carrier Code	E2A	E2B
Shim	No	Yes
Carrier Height	16.70mm	17.55mm

XCC Carrier

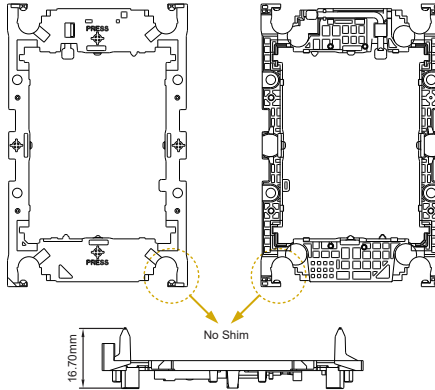

HCC/LCC/HDCC Carrier

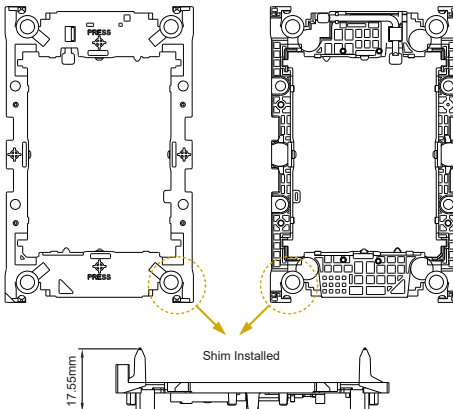



Before inserting the CPU into the socket, please check if the PnP cap is on the socket, if the CPU surface is unclean, or if there are any bent pins in the socket. Do not force to insert the CPU into the socket if above situation is found. Otherwise, the CPU will be seriously damaged.

1

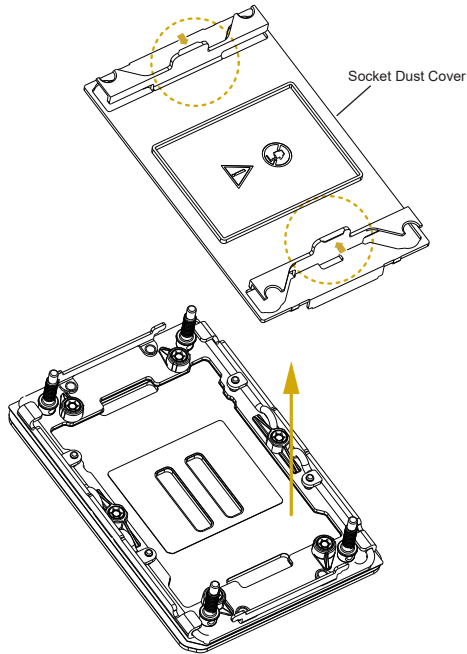

2

Installing CPU:
Align the Pin1 mark to install the CPU

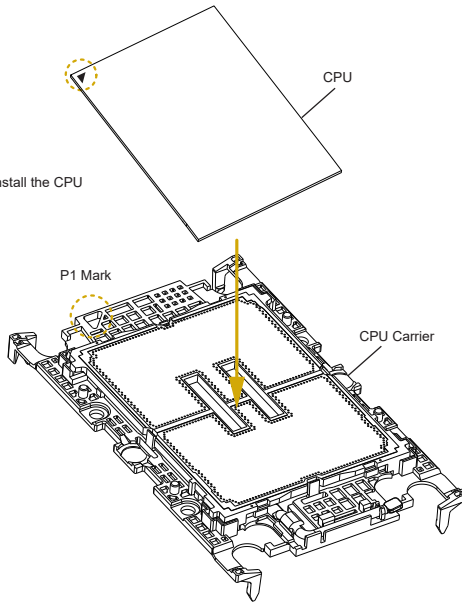

Removing CPU:
Press the lever to remove the CPU

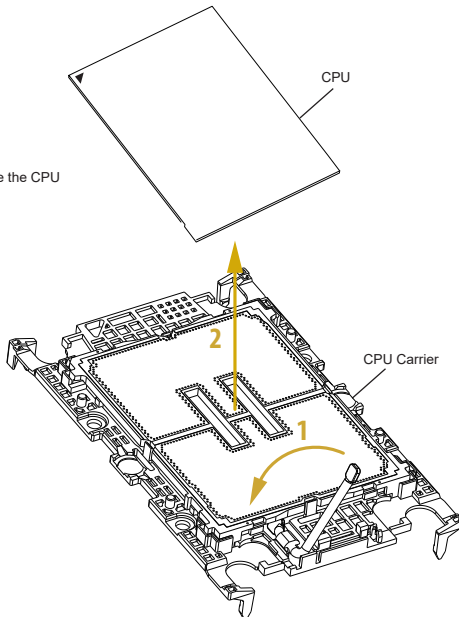

3

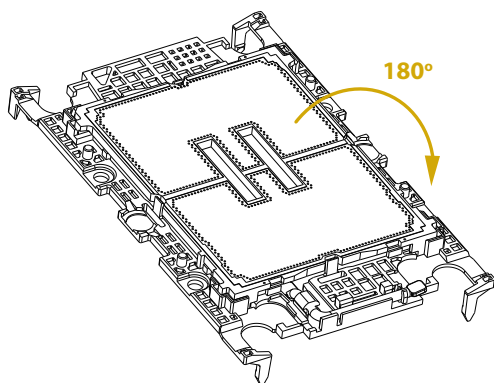

4

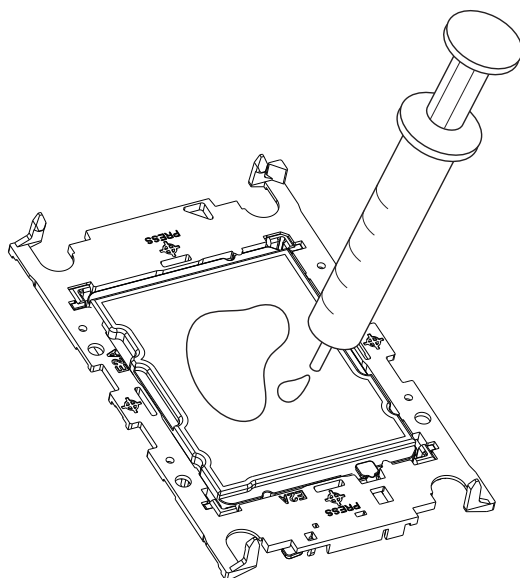

5

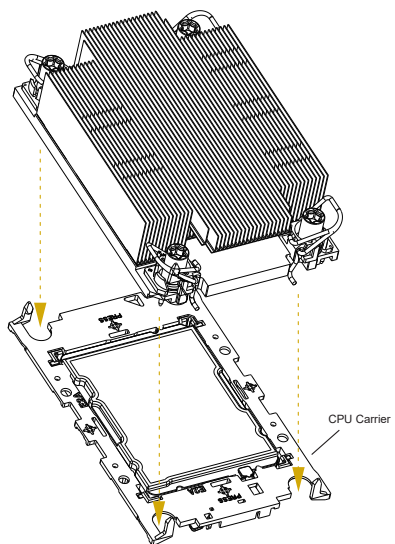

6

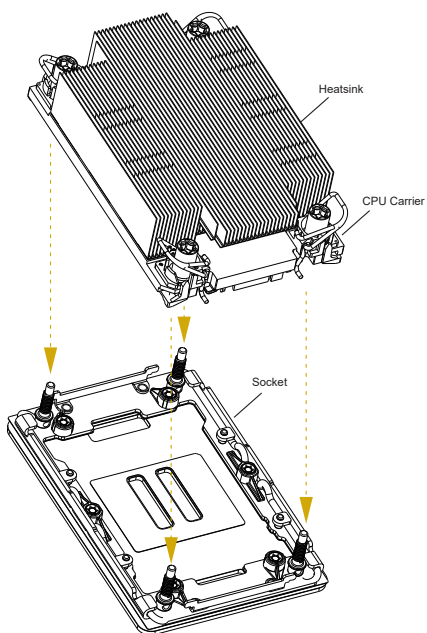

7

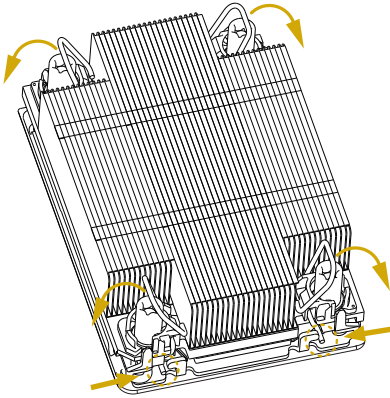

8

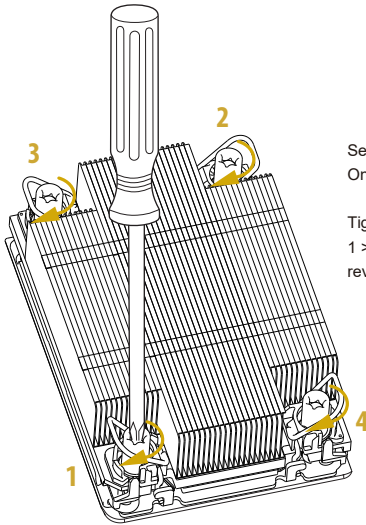

Set the torque wrench to 6-12 in-lb.
One fourth a turn each time.

Tighten the screws in a sequential order
1 > 2 > 3 > 4. Loosen the screws in a
reverse order.



PCB thickness is crucial when using the cooling device. Please select the compatible CPU fan(s) or heatsink(s).

2.4 Installing the Memory Modules (DIMM)

This motherboard provides eight DDR5 (Double Data Rate 5) DIMM slots in two groups, and supports Single Channel Memory Technology.



1. Before installing a memory module, make sure to turn off the computer and unplug the powercord from the power outlet to prevent damage to the memory module.
2. It is not allowed to install a DDR, DDR2, DDR3 or DDR4 memory module into a DDR5 slot; otherwise, this motherboard and DIMM may be damaged.
3. For eight channel configuration, it always needs to install identical (the same brand, speed, size and chip-type) DDR5 DIMMs.

Recommended Memory Configurations

	CPU0							
	A1	B1	C1	D1	E1	F1	G1	H1
1 DIMM	V							
4 DIMMS	V		V		V		V	
8 DIMMS	V	V	V	V	V	V	V	V

The symbol V indicates the slot is populated.

1

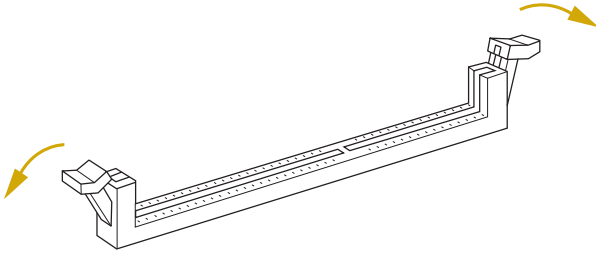

2

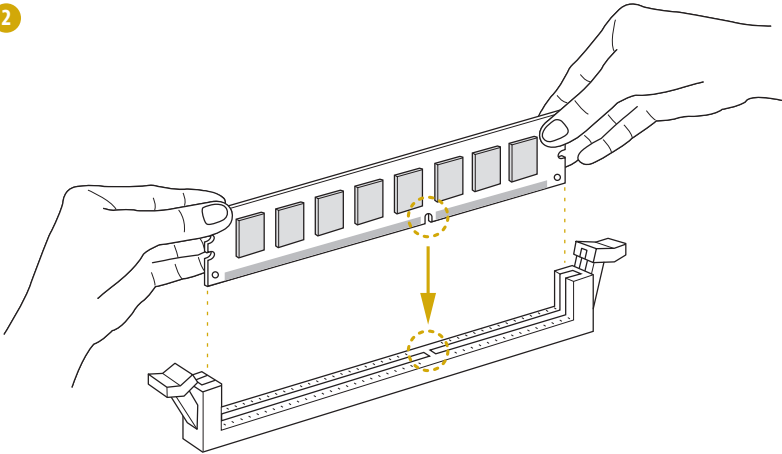

3

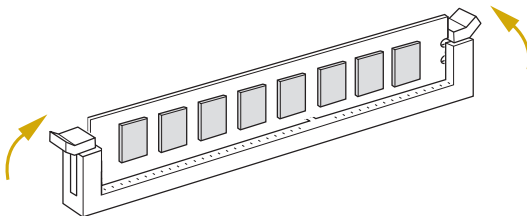

2.5 Expansion Slots (PCI Express Slots)

There are 7 PCI Express slots on this motherboard.

PCIE slots:

PCIE1 (PCIe 5.0 x16 slot, from CPU) is used for PCI Express x16 lane width cards.

PCIE2 (PCIe 5.0 x16 slot, from CPU) is used for PCI Express x16 lane width cards.

PCIE3 (PCIe 5.0 x16 slot, from CPU) is used for PCI Express x16 lane width cards.

PCIE4 (PCIe 5.0 x16 slot, from CPU) is used for PCI Express x16 lane width cards.

PCIE5 (PCIe 5.0 x16 slot, from CPU) is used for PCI Express x16 lane width cards.

PCIE6 (PCIe 5.0 x16 slot, from CPU) is used for PCI Express x16 lane width cards.

PCIE7 (PCIe 5.0 x16 slot, from CPU) is used for PCI Express x16 lane width cards.

Slot	Generation	Mechanical	Electrical	Source
PCIE1	5.0	x16	x16	CPU0
PCIE2*	5.0	x16	x16	CPU0
PCIE3	5.0	x16	x16	CPU0
PCIE4*	5.0	x16	x16	CPU0
PCIE5	5.0	x16	x16	CPU0
PCIE6	5.0	x16	x16	CPU0
PCIE7*	5.0	x16	x16	CPU0

**For RIO (Rich IO) BHS*

Installing an expansion card

- Step 1. Before installing an expansion card, please make sure that the power supply is switched off or the power cord is unplugged. Please read the documentation of the expansion card and make necessary hardware settings for the card before starting the installation.
- Step 2. Remove the system unit cover (if the motherboard is already installed in a chassis).
- Step 3. Remove the bracket facing the slot that intending to use on the chassis. Keep the screw for later use.
- Step 4. Install the PCIE card to the riser card.
- Step 5. Align the riser-card assembly connector with the slot on the system board. Press firmly until the riser-card assembly is completely seated on the slot.
- Step 6. Fasten the card to the chassis with the screw.
- Step 7. Replace the system cover.

2.6 Onboard Headers and Connectors



Onboard headers and connectors are NOT jumpers. Do NOT place jumper caps over these headers and connectors. Placing jumper caps over the headers and connectors will cause permanent damage to the motherboard.

System Panel Header
(9-pin PANEL1)
(see p.6, No. 29)

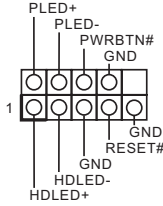

Connect the power switch, reset switch and system status indicator on the chassis to this header according to the pin assignments. Particularly note the positive and negative pins before connecting the cables.



PWRBTN (Power Switch):

Connect to the power switch on the chassis front panel and configure the way to turn off the system using the power switch.

RESET (Reset Switch):

Connect to the reset switch on the chassis front panel. Press the reset switch to restart the computer if the computer freezes and fails to perform a normal restart.

PLED (System Power LED):

Connect to the power status indicator on the chassis front panel. The LED is on when the system is operating. The LED is off when the system is in S4 sleep state or powered off (S5).

HDLED (Hard Drive Activity LED):

Connect to the hard drive activity LED on the chassis front panel. The LED is on when the hard drive is reading or writing data.

The front panel design may differ by chassis. A front panel module mainly consists of power switch, reset switch, power LED, hard drive activity LED, speaker and etc. When connecting the chassis front panel module to this header, make sure the wire assignments and the pin assignments are matched correctly.

Auxiliary Panel Header
(18-pin AUX PANEL1)
(see p.6, No. 30)

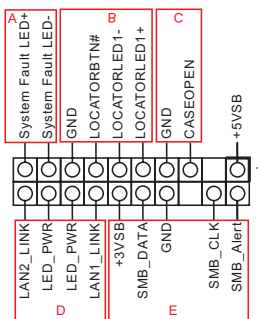

This header supports multiple functions on the front panel, including the front panel SMB, internet status indicator and chassis intrusion pin.



A. System Fault LED (2-pin SYSTEM STATUS)

This header is for the Fault LED on the system.

B. Locator LED (4-pin LOCATOR)

This header is for the locator switch and LED on the front panel.

C. Chassis intrusion pin (2-pin CHASSIS)

This header is provided for host computer chassis with chassis intrusion detection designs. In addition, it must also work with external detection equipment, such as a chassis intrusion detection sensor or a microswitch. When this function is activated, if any chassis component movement occurs, the sensor will immediately detect it and send a signal to this header, and the system will then record this chassis intrusion event. The default setting is set to the CASEOPEN and GND pin; this function is off.

D. Internet status indicator (2-pin LAN1_LED, LAN2_LED)

These two 2-pin headers allow user to use the Gigabit internet indicator cable to connect to the LAN status indicator. When this indicator flickers, it means that the internet is properly connected.

E. Front panel SMBus connecting pin (6-1 pin FPSMB)

This header allows user to connect SMBus (System Management Bus) equipment. It can be used for communication between peripheral equipment in the system, which has slower transmission rates, and power management equipment.

Non Maskable Interrupt
Button Header
(NMI_BTN1)
(see p.6, No. 34)



Please connect a NMI device to this header.

USB 3.2 Gen1 Header
(19-pin USB3_1_1)
(see p.6, No. 15)

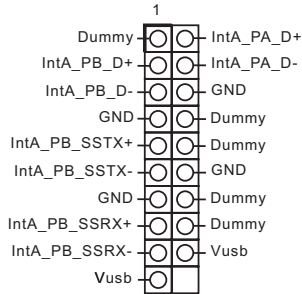

Besides two default USB 3.2 Gen1 ports on the I/O panel, there is one USB 3.2 Gen1 header on this motherboard. This header can support one USB 3.2 and one USB2.0.

SPI TPM Header
(13-pin TPM1)
(see p.6, No. 38)

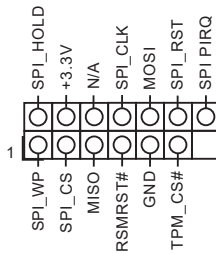

This connector supports SPI Trusted Platform Module (TPM) system, which can securely store keys, digital certificates, passwords, and data. A TPM system also helps enhance network security, protects digital identities, and ensures platform integrity.

COM Port Header
(9-pin COM1)
(see p.6, No. 33)

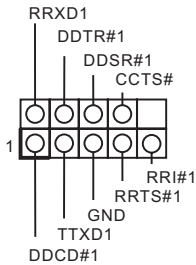

This COM1 header supports a serial port module.

Front LAN LED Header
(4-pin LED_LAN_3_4)
(see p.6, No. 32)

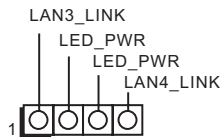

This 4-pin connector is used for the front LAN status indicator.

PWM Configuration Header
(3-pin PWM_CFG1)
(see p.6, No. 2)

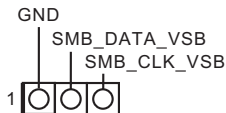

This header is used for PWM configurations.

ATX 12V Power

Connectors

(8-pin ATX12V1)

(see p.6, No. 9)

(8-pin ATX12V2)

(see p.6, No. 10)

(8-pin ATX12V3)

(see p.6, No. 13)

(8-pin ATX12V4)

(see p.6, No. 3)

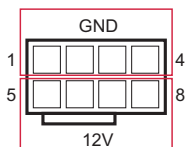

This motherboard provides four 8-pin ATX 12V power connectors.

ATX Power Connector

(24-pin ATXPWR1)

(see p.6, No. 8)

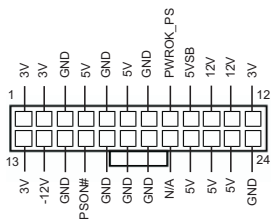

This motherboard provides a 24-pin ATX power connector.

To use a 20-pin ATX power supply, please plug it along Pin 1 and Pin 13.

System Fan Headers

(6-pin FAN1)

(see p.6, No. 7)

(6-pin FAN2)

(see p.6, No. 11)

(6-pin FAN3)

(see p.6, No. 23)

(6-pin FAN4)

(see p.6, No. 25)

(6-pin FAN5)

(see p.6, No. 27)

(6-pin FAN6)

(see p.6, No. 22)

(6-pin FAN7)

(see p.6, No. 24)

(6-pin FAN8)

(see p.6, No. 26)

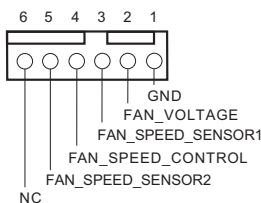

Please connect fan cables to the fan headers and match the black wire to the ground pin. All fans support Fan Control. The fan max. current is 5A and the max. power is 60Watts.

PSU SMBus
(PSU_SMB1)
(see p.6, No. 6)

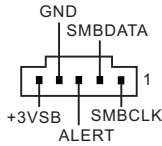

PSU SMBus monitors the status of the power supply, fan and system temperature.

Intelligent Platform
Management Bus header
(4-pin IPMB_1)
(see p.6, No. 37)

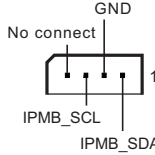

This 4-pin connector is used to provide a cabled base-board or front panel connection for value added features and 3rd-party add-in cards, such as Emergency Management cards, that provide management features using the IPMB.

BMC SMBus Headers
(5-pin BMC_SMB_1)
(see p.6, No. 35)
(5-pin BMC_SMB_2)
(see p.6, No. 36)

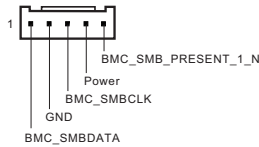

These headers are used for the SM BUS devices.

Backplane PCI Express
Hot-Plug Connector
(5-pin CPU0_HSBP1)
(see p.6, No. 1)

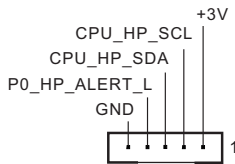

This header is used for the hot plug feature of HDDs on the backplane.

MicroSD Card Slot (SDC1)
(see p.6, No. 21)

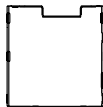

Carefully insert the SD Card into the slot until it clicks.

Clear CMOS Pad
(CLRMOS1)
(see p.6, No. 31)



CLRMOS1 allows user to clear the data in CMOS. To clear CMOS, take out the CMOS battery and short the Clear CMOS Pad.

Virtual RAID On CPU
Header
(4-pin RAID_1)
(see p.6, No. 28)

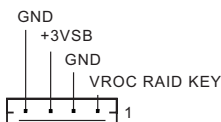

This connector supports Intel® Virtual RAID on CPU and NVME/AHCI RAID on CPU PCIE.

With the introduction of the Intel VROC product, there are three modes of operation:

SKU	HW key required	Key features
Pass-thru	Not needed	<ul style="list-style-type: none"> • Pass-thru only (no RAID) • LED Management • Hot Plug Support • RAID 0 support for Intel Fultondale NVMe SSDs
Standard	VROCSTANMOD	<ul style="list-style-type: none"> • Pass-thru SKU features • RAID 0, 1, 10
Premium	VROCPREMMOD	<ul style="list-style-type: none"> • Standard SKU features • RAID 5
ISS	VROCISSDMOD	<ul style="list-style-type: none"> • RAID 5 Write Hole Closure

*Only Intel SSDs are supported.

*For further details on VROC, please refer to the official information released by Intel.

MCIO Connector
(MCIO1)
(see p.6, No. 16)



The connector is used for the PCIE device.

MCIO1 Pin Definition

Pin	Definition	Pin	Definition
A1	GND	B1	GND
A2	RX_DP0	B2	TX_DP0
A3	RX_DN0	B3	TX_DN0
A4	GND	B4	GND
A5	RX_DP1	B5	TX_DP1
A6	RX_DN1	B6	TX_DN1
A7	GND	B7	GND
A8	BP_TYPE	B8	SCL1
A9	WAKE1	B9	SDA1
A10	GND	B10	GND
A11	MCIO1A_CLKP	B11	PERST_BUF1_N
A12	MCIO1A_CLKN	B12	CHANG_DET_N
A13	GND	B13	GND
A14	RX_DP2	B14	TX_DP2
A15	RX_DN2	B15	TX_DN2
A16	GND	B16	GND
A17	RX_DP3	B17	TX_DP3
A18	RX_DN3	B18	TX_DN3
A19	GND	B19	GND
A20	RX_DP4	B20	TX_DP4
A21	RX_DN4	B21	TX_DN4
A22	GND	B22	GND
A23	RX_DP5	B23	TX_DP5
A24	RX_DN5	B24	TX_DN5
A25	GND	B25	GND
A26	BP_TYPE	B26	SCL2
A27	WAKE2	B27	SDA2
A28	GND	B28	GND
A29	MCIO1B_CLKP	B29	PERST_BUF2_N
A30	MCIO1B_CLKN	B30	PRSNT2_N
A31	GND	B31	GND
A32	RX_DP6	B32	TX_DP6
A33	RX_DN6	B33	TX_DN6
A34	GND	B34	GND
A35	RX_DP7	B35	TX_DP7
A36	RX_DN7	B36	TX_DN7
A37	GND	B37	GND
75	NP_NC_1	76	NP_NC_2
77	PGND_1	78	PGND_3
79	PGND_2	80	PGND_4

2.7 Unit Identification purpose LED/Switch

Use the UID button to locate the server working on behind a rack of servers.

Unit Identification
purpose LED/Switch
(UID1)



When the UID button on the front or rear panel is pressed, the front/rear UID blue LED indicator will be turned on. Press the UID button again to turn off the indicator.



- 1. Press and hold the UID button for 4 seconds, the BMC will trigger an external reset.*
- 2. Press and hold the UID button for 10 seconds, the BMC will reset and load default values.*

2.8 Dr. Debug

Dr. Debug is used to provide code information, which makes troubleshooting even easier. Please see the diagrams below for reading the Dr. Debug codes.

Code	Description
0x10	PEI_CORE_STARTED
0x11	PEI_CAR_CPU_INIT
0x15	PEI_CAR_NB_INIT
0x19	PEI_CAR_SB_INIT
0x31	PEI_MEMORY_INSTALLED
0x32	PEI_CPU_INIT
0x33	PEI_CPU_CACHE_INIT
0x34	PEI_CPU_AP_INIT
0x35	PEI_CPU_BSP_SELECT
0x36	PEI_CPU_SMM_INIT
0x37	PEI_MEM_NB_INIT
0x3B	PEI_MEM_SB_INIT
0x4F	PEI_DXE_IPL_STARTED
0x60	DXE_CORE_STARTED
0x61	DXE_NVRAM_INIT
0x62	DXE_SBRUN_INIT

0x63	DXE_CPU_INIT
0x68	DXE_NB_HB_INIT
0x69	DXE_NB_INIT
0x6A	DXE_NB_SMM_INIT
0x70	DXE_SB_INIT
0x71	DXE_SB_SMM_INIT
0x72	DXE_SB_DEVICES_INIT
0x78	DXE_ACPI_INIT
0x79	DXE_CSM_INIT
0x90	DXE_BDS_STARTED
0x91	DXE_BDS_CONNECT_DRIVERS
0x92	DXE_PCI_BUS_BEGIN
0x93	DXE_PCI_BUS_HPC_INIT
0x94	DXE_PCI_BUS_ENUM
0x95	DXE_PCI_BUS_REQUEST_RESOURCES
0x96	DXE_PCI_BUS_ASSIGN_RESOURCES
0x97	DXE_CON_OUT_CONNECT
0x98	DXE_CON_IN_CONNECT

0x99	DXE_SIO_INIT
0x9A	DXE_USB_BEGIN
0x9B	DXE_USB_RESET
0x9C	DXE_USB_DETECT
0x9D	DXE_USB_ENABLE
0xA0	DXE_IDE_BEGIN
0xA1	DXE_IDE_RESET
0xA2	DXE_IDE_DETECT
0xA3	DXE_IDE_ENABLE
0xA4	DXE_SCSI_BEGIN
0xA5	DXE_SCSI_RESET
0xA6	DXE_SCSI_DETECT
0xA7	DXE_SCSI_ENABLE
0xA8	DXE_SETUP_VERIFYING_PASSWORD
0xA9	DXE_SETUP_START
0xAB	DXE_SETUP_INPUT_WAIT
0xAD	DXE_READY_TO_BOOT
0xAE	DXE_LEGACY_BOOT

0xAF	DXE_EXIT_BOOT_SERVICES
0xB0	RT_SET_VIRTUAL_ADDRESS_MAP_BEGIN
0xB1	RT_SET_VIRTUAL_ADDRESS_MAP_END
0xB2	DXE_LEGACY_OPROM_INIT
0xB3	DXE_RESET_SYSTEM
0xB4	DXE_USB_HOTPLUG
0xB5	DXE_PCI_BUS_HOTPLUG
0xB6	DXE_NVRAM_CLEANUP
0xB7	DXE_CONFIGURATION_RESET
0xF0	PEI_RECOVERY_AUTO
0xF1	PEI_RECOVERY_USER
0xF2	PEI_RECOVERY_STARTED
0xF3	PEI_RECOVERY_CAPSULE_FOUND
0xF4	PEI_RECOVERY_CAPSULE_LOADED
0xE0	PEI_S3_STARTED
0xE1	PEI_S3_BOOT_SCRIPT
0xE2	PEI_S3_VIDEO_REPOST

0xE3	PEI_S3_OS_WAKE
0x50	PEI_MEMORY_INVALID_TYPE
0x53	PEI_MEMORY_NOT_DETECTED
0x55	PEI_MEMORY_NOT_INSTALLED
0x57	PEI_CPU_MISMATCH
0x58	PEI_CPU_SELF_TEST_FAILED
0x59	PEI_CPU_NO_MICROCODE
0x5A	PEI_CPU_ERROR
0x5B	PEI_RESET_NOT_AVAILABLE
0xD0	DXE_CPU_ERROR
0xD1	DXE_NB_ERROR
0xD2	DXE_SB_ERROR
0xD3	DXE_ARCH_PROTOCOL_NOT_AVAILABLE
0xD4	DXE_PCI_BUS_OUT_OF_RESOURCES
0xD5	DXE_LEGACY_OPROM_NO_SPACE
0xD6	DXE_NO_CON_OUT
0xD7	DXE_NO_CON_IN

0xD8	DXE_INVALID_PASSWORD
0xD9	DXE_BOOT_OPTION_LOAD_ERROR
0xDA	DXE_BOOT_OPTION_FAILED
0xDB	DXE_FLASH_UPDATE_FAILED
0xDC	DXE_RESET_NOT_AVAILABLE
0xE8	PEI_MEMORY_S3_RESUME_FAILED
0xE9	PEI_S3_RESUME_PPI_NOT_FOUND
0xEA	PEI_S3_BOOT_SCRIPT_ERROR
0xEB	PEI_S3_OS_WAKE_ERROR

2.9 Dual LAN and Teaming Operation Guide

Dual LAN with Teaming enabled on this motherboard allows two single connections to act as one single connection(s) for twice the transmission bandwidth, making data transmission more effective and improving the quality of transmission of distant images. Fault tolerance on the dual LAN network prevents network downtime by transferring the workload from a failed port to a working port.



The speed of transmission is subject to the actual network environment or status even with Teaming enabled.

Before setting up Teaming, please make sure whether the Switch (or Router) supports Teaming (IEEE 802.3ad Link Aggregation). Specify a preferred adapter in Intel PROSet. Under normal conditions, the Primary adapter handles all non-TCP/IP traffic. The Secondary adapter will receive fallback traffic if the primary fails. If the Preferred Primary adapter fails, but is later restored to an active status, control is automatically switched back to the Preferred Primary adapter.

Step 1

From **Device Manager**, open the properties of a team.

Step 2

Click the **Settings** tab.

Step 3

Click the **Modify Team** button.

Step 4

Select the adapter to the primary adapter and click the **Set Primary** button.

If it does not specify a preferred primary adapter, the software will choose an adapter of the highest capability (model and speed) to act as the default primary. If a failover occurs, another adapter becomes the primary. The adapter will, however, rejoin the team as a non-primary.

2.10 M.2_SSD Module Installation Guide

The M.2 Socket (M2_1/M2_2, Key M) supports type 2280/22110 M.2 SATA 6.0 Gb/s module or M.2 PCI Express module up to Gen5 x4 (32GT/s x4).

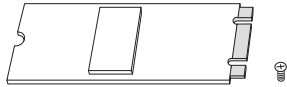

Step 1

Prepare a M.2 SSD module and the screw.

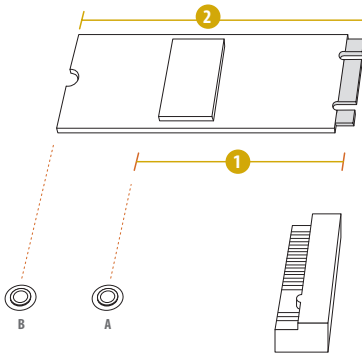

Step 2

Depending on the PCB type and length of the M.2 SSD module, find the corresponding nut location to be used.

No.	1	2
Nut Location	A (NUT2280_1/NUT2280_2)	B (NUT22110_1/NUT22110_2)
PCB Length	8 cm	11 cm
Module Type	Type 2280	Type 22110

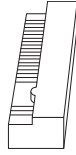
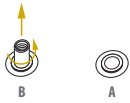
**Step 3**

Move the standoff based on the module type and length.
Skip Step 3 and 4 and go straight to Step 5 if using the default nut.
Otherwise, release the standoff by hand.

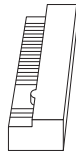
**Step 4**

Peel off the yellow protective film on the nut to be used. Hand tighten the standoff into the desired nut location on the motherboard.

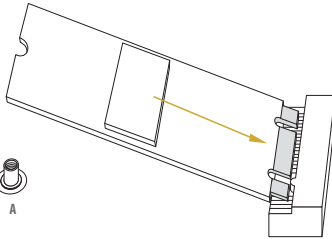
**Step 5**

Align and gently insert the M.2 SSD module into the M.2 slot. Please be aware that the M.2 SSD module only fits in one orientation.

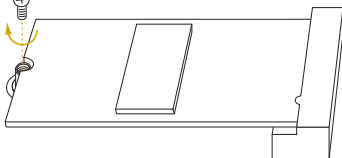
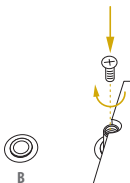
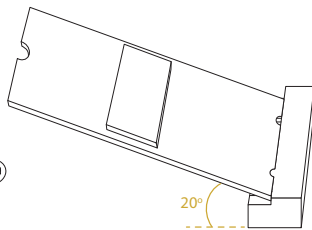
**Step 6**

Tighten the screw with a screwdriver to secure the module into place. Please do not overtighten the screw as this might damage the module.

Chapter 3 UEFI Setup Utility

3.1 Introduction

This section explains how to use the UEFI SETUP UTILITY to configure the system. The UEFI chip on the motherboard stores the UEFI SETUP UTILITY. Run the UEFI SETUP UTILITY when starting up the computer. Please press <F2> or during the Power-On-Self-Test (POST) to enter the UEFI SETUP UTILITY; otherwise, POST will continue with its test routines.

Restart the system by pressing <Ctrl> + <Alt> + <Delete> to enter the UEFI SETUP UTILITY after POST, or by pressing the reset button on the system chassis. This allows user to restart by turning the system off and then back on.



Because the UEFI software is constantly being updated, the following UEFI setup screens and descriptions are for reference purpose only, and they may not exactly match what seeing on the screen.

3.1.1 UEFI Menu Bar

The top of the screen has a menu bar with the following selections:

Item	Description
Main	To set up the system time/date information
Advanced	To set up the advanced UEFI features
Server Mgmt	To manage the server
Event Logs	For event log configuration
Security	To set up the security features
Boot	To set up the default system device to locate and load the Operating System
Exit	To exit the current screen or the UEFI SETUP UTILITY

Use <←→> key or <→> key to choose among the selections on the menu bar, and then press <Enter> to get into the sub screen.

3.1.2 Navigation Keys

Please check the following table for the function description of each navigation key.

Navigation Key(s)	Function Description
← / →	Moves cursor left or right to select Screens
↑ / ↓	Moves cursor up or down to select items
+ / -	To change option for the selected items
<Tab>	Switch to next function
<Enter>	To bring up the selected screen
<PGUP>	Go to the previous page
<PGDN>	Go to the next page
<HOME>	Go to the top of the screen
<END>	Go to the bottom of the screen
<F1>	To display the General Help Screen
<F7>	Discard changes and exit the UEFI SETUP UTILITY
<F9>	Load optimal default values for all the settings
<F10>	Save changes and exit the UEFI SETUP UTILITY
<F12>	Print screen
<ESC>	Jump to the Exit Screen or exit the current screen

3.2 Main Screen

Once entering the UEFI SETUP UTILITY, the Main screen will appear and display the system overview. The Main screen provides system overview information and allows user to set the system time and date.

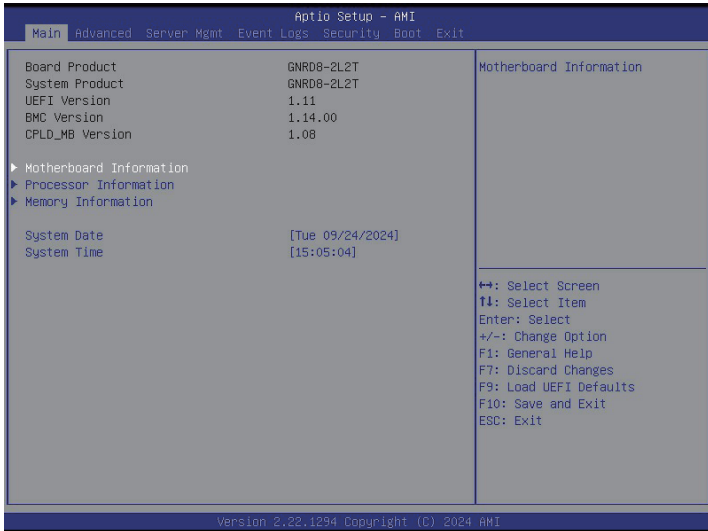

3.2.1 Mother Board Information

Press <Enter> to view the information of the motherboard.

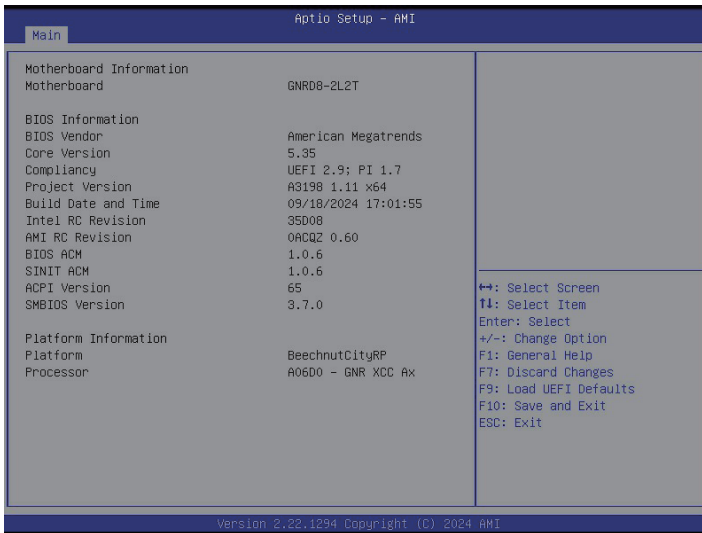

3.2.2 Processor Information

Press <Enter> to view the information of the processor.

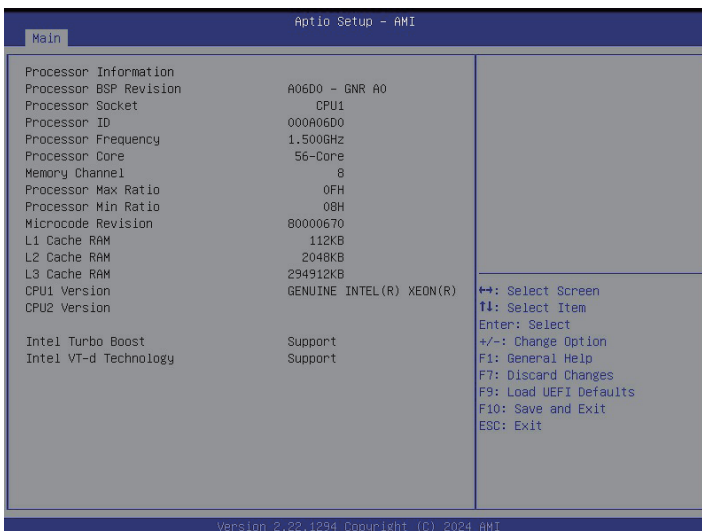

3.2.3 Memory Information

Press <Enter> to view the information of the memory.

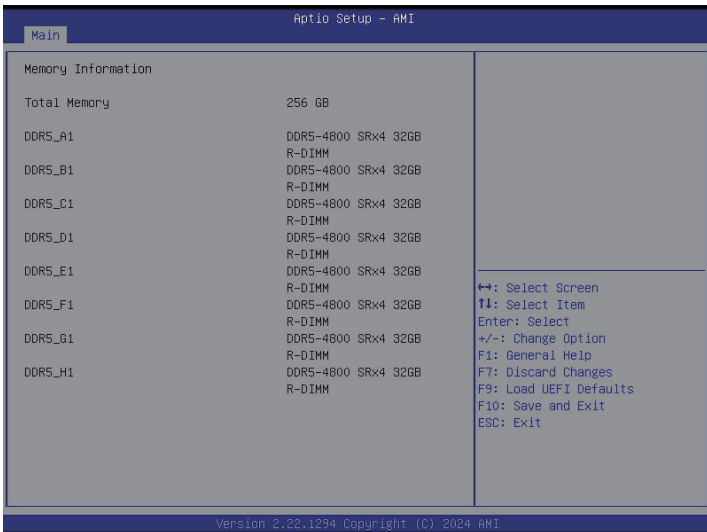

3.3 Advanced Screen

In this section, set the configurations for the following items: CPU Configuration, Platform Power Configuration, DRAM Configuration, Chipset Configuration, NVMe Configuration, ACPI Configuration, USB Configuration, Serial Port Console Redirection, H/W Monitor, Network Stack Configuration, Intel VMD Technology, Driver Health, Tls Auth Configuration and Instant Flash.

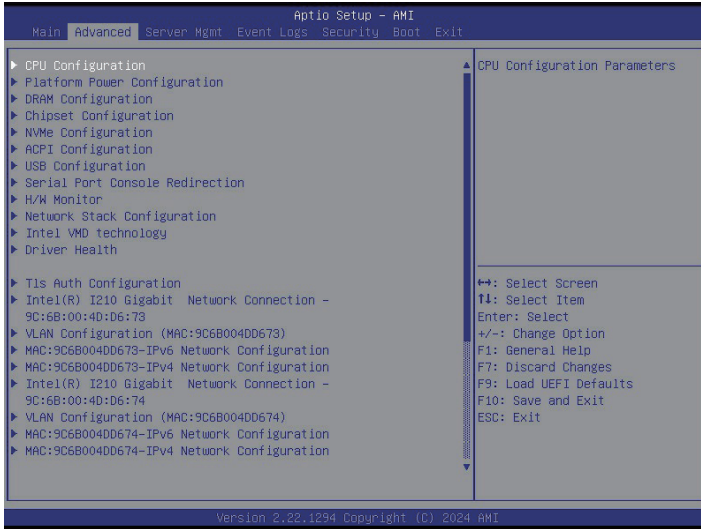

Setting wrong values in this section may cause the system to malfunction.

3.3.1 CPU Configuration

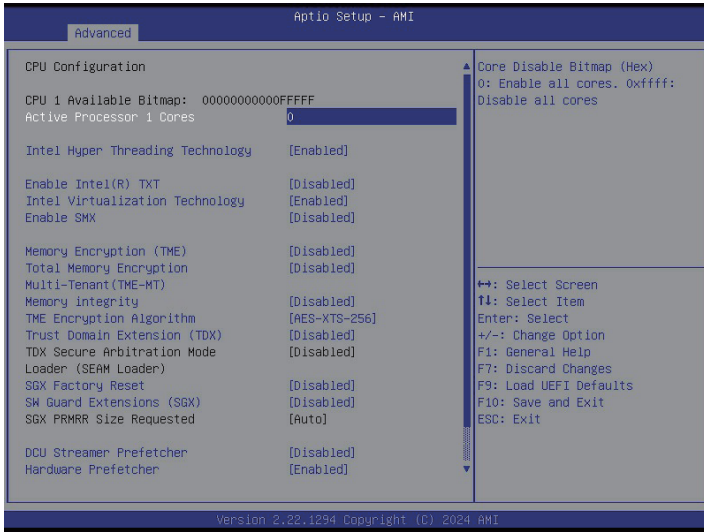

Active Processor 1 Cores

Core Disable Bitmap (Hex)

0: Enable all cores.

0xffff: Disable all cores.

Intel Hyper Threading Technology

Intel Hyper Threading Technology allows multiple threads to run on each core, so that the overall performance on threaded software is improved.

Enable Intel(R) TXT

Enables Intel Trusted Execution Technology Configuration.

Intel Virtualization Technology

Intel Virtualization Technology allows a platform to run multiple operating systems and applications in independent partitions, so that one computer system can function as multiple virtual systems.

Enable SMX

Use this item to enable Safer Mode Extensions.

Memory Encryption (TME)

Use this item to enable or disable Memory Encryption (TME).

Total Memory Encryption

Use this item to enable or disable Total Memory Encryption.

TME Encryption Algorithm

Use this item to select TME Encryption Algorithm.

Trust Domain Extension (TDX)

Use this item to enable or disable TDX.

TDX Secure Arbitration Mode Loader (SEAM Loader)

Use this item to enable or disable SEAM Loader.

SGX Factory Reset

Use this item to enable or disable SGX Factory Reset.

SW Guard Extensions (SGX)

Use this item to enable or disable Software Guard Extensions (SGX).

SGX PRMRR size Requested

Configure the SGX PRMRR size Requested, the default value is [Auto].

DCU Streamer Prefetcher

DCU streamer prefetcher is an L1 data cache prefetcher (MSR 1A4h [2]).

Hardware Prefetcher

Automatically prefetch data and code for the processor. Enable for better performance.

Adjacent Cache Line Prefetch

Automatically prefetch the subsequent cache line while retrieving the currently requested cache line. Enable for better performance.

AES-NI

Use this item to enable or disable AES-NI support.

SNC (Sub NUMA)

SNC disable will support 1-cluster (XPT/KTI Prefetch enable) 4-IMC way interleave. SNC2 Enable supports 2-clusters SNC and 2-way IMC interleave. SNC4 Enable supports 4-clusters SNC and 1-way IMC interleave. Enable SNC2 or SNC4 will gray out iMC_ Interleave knob and UmaBasedClustering knob.

3.3.2 Platform Power Configuration

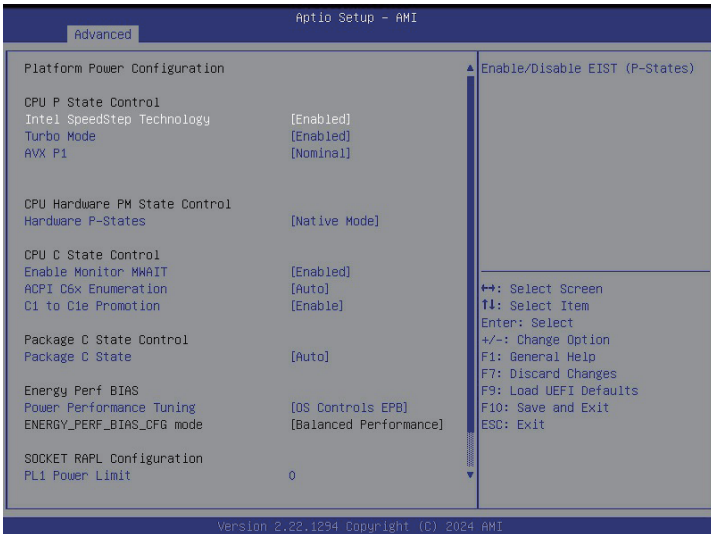

Intel SpeedStep Technology

Intel SpeedStep technology allows processors to switch between multiple frequencies and voltage points for better power saving and heat dissipation. CPU turbo ratio can be fixed when Intel SpeedStep Technology set Disabled and Intel Turbo Boost Technology set Enabled.



Please note that enabling this function may reduce CPU voltage and lead to system stability or compatibility issues with some power supplies. Please set this item to [Disabled] if above issues occur.

Turbo Mode

Use this item to enable or disable Turbo Mode.

AVX P1

Use this item to select AVX P1 level.

Hardware P-States

Disable: Hardware chooses a P-state based on OS Request (Legacy P-States).

Native Mode: Hardware chooses a P-state based on OS guidance.

Out of Band Mode: Hardware autonomously chooses a P-state (no OS guidance).

Enable Monitor MWAIT

This item allows user to configure Monitor and MWAIT instructions whether Auto maps to enable.

ACPI C6x Enumeration

Configure the ACPI C6x Enumeration, the default value is [Auto].

C1 to C1e Promotion

Use this item to enable or disable the C1 to C1e Promotion.

Package C State

Enable CPU, PCIe, Memory, Graphics C State Support for power saving.

Power Performance Tuning

Use this item to decides which controls EFB.

OS Controls EPB: Specifies IA32_ENERGY_PERF_BIAS is used.

BIOS Controls EPB: Specifies ENERGY_PERF_BIAS_CONFIG is used.

PECI Controls EPB: Specifies PCS53 is used.

ENERGY_PERF_BIAS_CFG mode

Use this item to use input from ENERGY_PERF_BIAS_CONFIG mode selection. PERF/Balanced, Perf/Balanced or Power/Power.

PL1 Power Limit

Use this item to configure Package Power Limit 1 (PL1) in watts. PL1 Power Limit is in Watts and the value may vary from 0 to Fused Value. If the value is 0, the fused value will be programmed. A value greater than fused TDP value will not be programmed.

PL1 Time Window

Use this item to configure the period of time until the CPU ratio is lowered when the Long Duration Power Limit is exceeded. PL1 value is in seconds. The value may vary from 0 to 448.

PL2 Power Limit

Use this item to configure Package Power Limit 2 (PL2) in watts. When the limit is exceed, the CPU ratio will be lowered immediately. A lower limit can protect the CPU and save power, while a higher limit may improve performance.

PL2 Time Window

Use this item to configure the period of time until the CPU ratio is lowered when the Short Duration Power Limit is exceeded.

3.3.3 DRAM Configuration

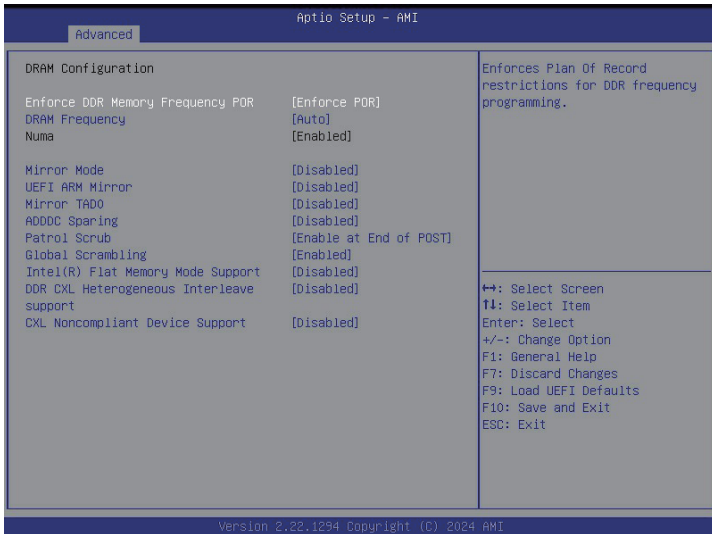

Enforce DDR Memory Frequency POR

Enable to enforce POR restrictions for DDR frequency and voltage programming.

DRAM Frequency

If [Auto] is selected, the motherboard will detect the memory module(s) inserted and assign the appropriate frequency automatically.

Numa

Use this item to enable or disable Non Uniform Memory Access (NUMA).

Mirror Mode

Full Mirror Mode will set entire 1LM memory in system to be mirrored, consequently reducing the memory capacity by half. Partial Mirror Mode will enable the required size of memory to be mirrored. If rank sparing is enabled partial mirroring will not take effect. Enabling any type of Mirror Mode will disable XPT Prefetch.

UEFI ARM Mirror

Use this item to enable or disable UEFI ARM Mirror.

Mirror TAD0

Use this item to enable or disable Mirror TAD0.

ADDDC Sparing

Use this item to enable or disable Memory Rank Sparing.

Patrol Scrub

Patrol Scrub is a background activity initiated by the processor to seek out and fix memory errors. The default value is [Enabled].

Global Scrambling

Use this item to enable or disable Global Scrambling.

Intel(R) Flat Memory Mode Support

Use this item to enable or disable Intel(R) Flat Memory Mode Support.

DDR CXL Heterogeneous Interleave Support

Use this item to enable or disable DDR CXL Heterogeneous Interleave Support.

CXL Noncompliant Device Support

Use this item to enable or disable CXL Noncompliant Device Support.

3.3.4 Chipset Configuration

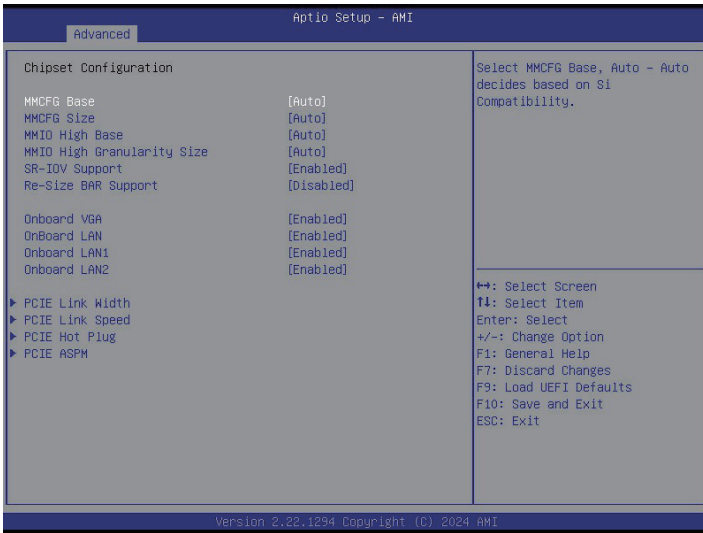

MMCFG Base

Use this item to select MMCFG Base. Auto-Auto decides based on Si compatibility.

MMCFG Size

Use this item to select MMCFG Size.

MMIO High Base

Use this item to select MMIO High Base.

MMIO High Granularity Size

Use this item to select MMIO Granularity Size.

SR-IOV Support

If system has SR-IOV capable PCIe Devices, this option Enables or Disables Single Root IO Virtualization Support. Only for PCH PCIe Devices.

Re-Size BAR Support

If system has Resizable BAR capable PCIe Devices, this option enables or disables Resizable BAR support.

Onboard VGA

Use this to enable or disable the Onboard VGA function.

Onboard LAN

Use this item to enable or disable the Boot From Onboard LAN feature.

Onboard LAN1

Use this item to enable or disable the Boot From Onboard LAN feature.

Onboard LAN2

Use this item to enable or disable the Boot From Onboard LAN feature.

PCIe Link Width

This displays the PCIe Link Width.

PCIe1/PCIe2/PCIe3/PCIe4/PCIe5/PCIe6/PCIe7, MCIO1 Link Width

All PCIe default values are [Auto]. Options: [x16], [x8x8], [x8x4x4], [x4x4x8] and [x4x4x4x4].

PCIe Link Speed

This displays the PCIe Link Speed.

PCIe1/PCIe2/PCIe3/PCIe4/PCIe5/PCIe6/PCIe7 Link Speed

Choose Link Speed for the PCIe port. Auto - up to Gen5 (32GT/s).

MCIO1-1/MCIO1-2/M2_1/M2_2 Link Speed

All of the default values are [Auto].

PCIe Hot Plug

Select this item to enable or disable Hot Plug for PCIe, MCIO and M.2.

PCIe1/PCIe2/PCIe3/PCIe4/PCIe5/PCIe6/PCIe7, MCIO1-1/1-2, M2_1/M2_2 Surprise Hot Plug

Use this item to enable or disable PCIe1/PCIe2/PCIe3/PCIe4/PCIe5/PCIe6/PCIe7, MCIO1-1/1-2 and M2_1/M2_2 Surprise Hot Plug.

PCIe ASPM

Select this item to disable ASPM support in all PCIe root ports.

PCIe1/PCIe2/PCIe3/PCIe4/PCIe5/PCIe6/PCIe7, MCIO1-1/1-2, M2_1/M2_2 ASPM Support

Use this item to configure the ASPM support to PCIe1/PCIe2/PCIe3/PCIe4/PCIe5/PCIe6/PCIe7, MCIO1-1/1-2 and M2_1/M2_2.

3.3.5 NVMe Configuration

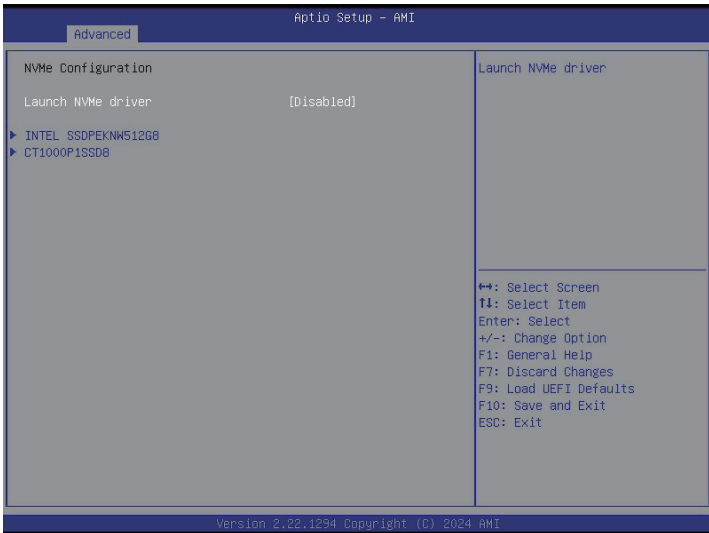

The NVMe Configuration displays the NVMe Drive Options Settings.

Launch NVMe driver

Select this item to enable or disable launch NVMe driver.

Self Test Option

Select either Short or Extended Self Test. Short option will take couple of minutes and extended option will take several minutes to complete.

Self Test Action

Select either to test Controller alone or Controller and Namespace. Selecting Controller and Namespace option will take lot longer to complete the test.

Run Device Self Test

Perform device self test for the corresponding Option and Action selected by user. Pressing 'Esc' key will abort the test. Result shown below is the recent result logged in the device.

3.3.6 ACPI Configuration

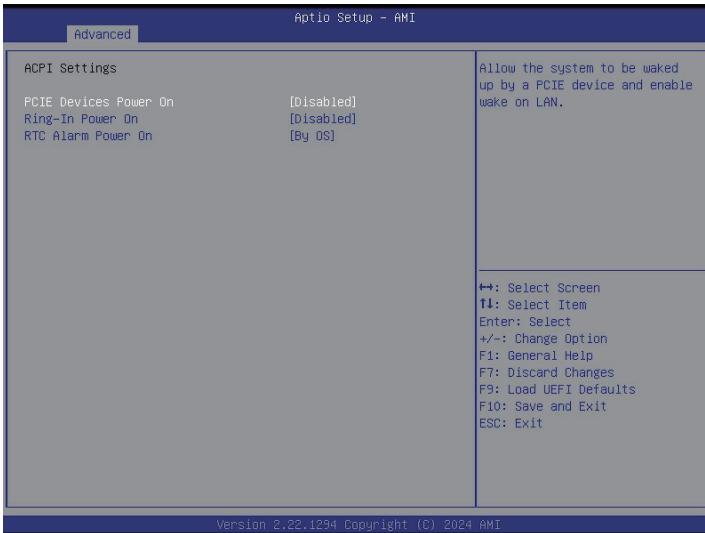

PCIE Devices Power On

Allow the system to be waked up by a PCIE device and enable wake on LAN.

Ring-In Power On

Allow the system to be waked up by onboard COM port modem Ring-In Signals.

RTC Alarm Power On

Allow the system to be waked up by real time clock alarm. Set it to By OS to let it be handled by the operating system.

RTC Alarm Date

Use this item to set Date of RTC power on feature.

RTC Alarm Hour

Use this item to set Hour of RTC power on feature.

RTC Alarm Minute

Use this item to set Minute of RTC power on feature.

RTC Alarm Second

Use this item to set Second of RTC power on feature.

3.3.7 USB Configuration

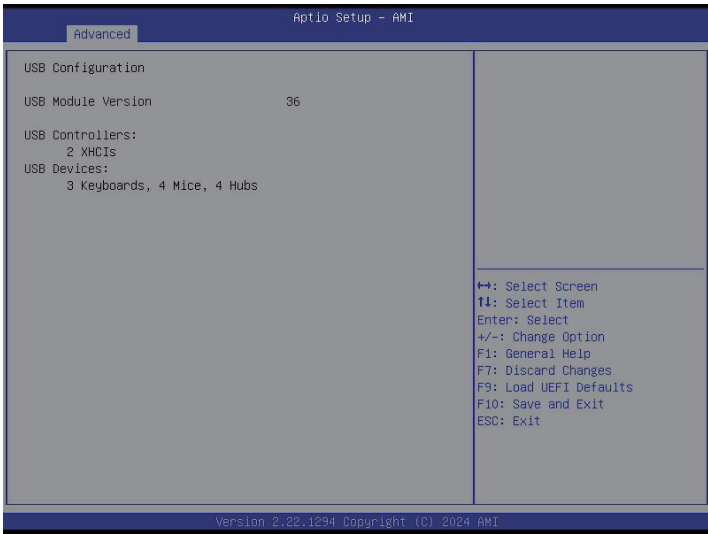

This displays the USB Module Version, Controllers and USB Devices information.

3.3.8 Serial Port Console Redirection

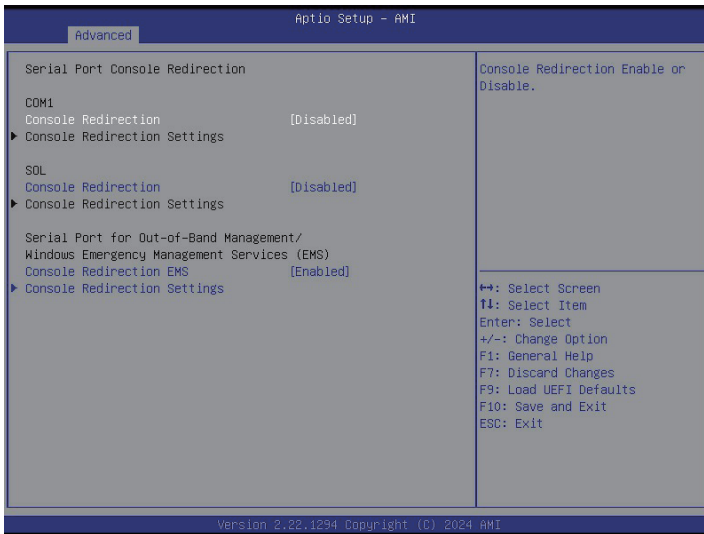

COM1 / SOL

Console Redirection

Use this option to enable or disable Console Redirection. If this item is set to Enabled, user can select a COM Port to be used for Console Redirection.

Console Redirection Settings

Use this option to configure Console Redirection Settings, and specify how the computer and the host computer to which are connected exchange information. Both computers should have the same or compatible settings.

Terminal Type

Use this item to select the preferred terminal emulation type for out-of-band management. It is recommended to select [VT-UTF8].

Option	Description
VT100	ASCII character set
VT100Plus	Extended VT100 that supports color and function keys
VT-UTF8	UTF8 encoding is used to map Unicode chars onto 1 or more bytes
ANSI	Extended ASCII character set

Bits Per Second

Use this item to select the serial port transmission speed. The speed used in the host computer and the client computer must be the same. Long or noisy lines may require lower transmission speed. The options include [9600], [19200], [38400], [57600] and [115200].

Data Bits

Use this item to set the data transmission size. The options include [7] and [8] (Bits).

Parity

Use this item to select the parity bit. The options include [None], [Even], [Odd], [Mark] and [Space].

Stop Bits

The item indicates the end of a serial data packet. The standard setting is [1] Stop Bit. Select [2] Stop Bits for slower devices.

Flow Control

Use this item to set the flow control to prevent data loss from buffer overflow. When sending data, if the receiving buffers are full, a "stop" signal can be sent to stop the data flow. Once the buffers are empty, a "start" signal can be sent to restart the flow. Hardware flow uses two wires to send start/stop signals. The options include [None] and [Hardware RTS/CTS].

VT-UTF8 Combo Key Support

Use this item to enable or disable the VT-UTF8 Combo Key Support for ANSI/VT100 terminals.

Recorder Mode

Use this item to enable or disable Recorder Mode to capture terminal data and send it as text messages.

Resolution 100x31

Use this item to enable or disable extended terminal resolution support.

Putty Keypad

Use this item to select Function Key and Keypad on Putty.

Serial Port for Out-of-Band Management/Windows Emergency Management Services (EMS)

Console Redirection EMS

Use this option to enable or disable Console Redirection EMS. If this item is set to Enabled, user can select a COM Port to be used for Console Redirection.

Console Redirection Settings

Use this option to configure Console Redirection Settings, and specify how the computer and the host computer to which are connected exchange information.

Out-of-Band Mgmt Port

Microsoft Windows Emergency Management Services (EMS) allows for remote management of a Windows Server OS through a serial port.

Terminal Type EMS

Use this item to select the preferred terminal emulation type for out-of-band management. It is recommended to select [VT-UTF8].

Option	Description
VT100	ASCII character set
VT100+	Extended VT100 that supports color and function keys
VT-UTF8	UTF8 encoding is used to map Unicode chars onto 1 or more bytes
ANSI	Extended ASCII character set

Bits Per Second EMS

Use this item to select the serial port transmission speed. The speed used in the host computer and the client computer must be the same. Long or noisy lines may require lower transmission speed. The options include [9600], [19200], [57600] and [115200].

Flow Control EMS

Use this item to set the flow control to prevent data loss from buffer overflow. When sending data, if the receiving buffers are full, a "stop" signal can be sent to stop the data flow. Once the buffers are empty, a "start" signal can be sent to restart the flow. Hardware flow uses two wires to send start/stop signals. The options include [None], [Hardware RTS/CTS], and [Software Xon/Xoff].

Data Bits EMS

Parity EMS

Stop Bits EMS

3.3.9 H/W Monitor

In this section, it allows user to monitor the status of the hardware on the system, including the parameters of the CPU temperature, motherboard temperature, CPU fan speed, chassis fan speed, and the critical voltage.

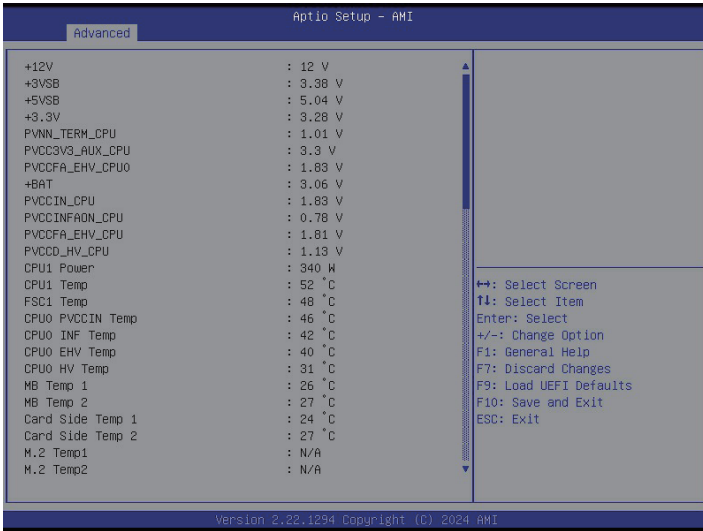

3.3.10 Network Stack Configuration

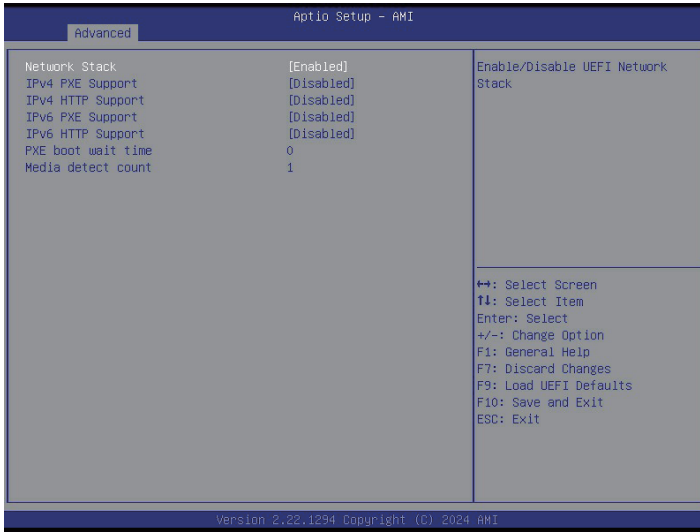

Network Stack

Use this to enable or disable UEFI Network Stack.

IPv4 PXE Support

Use this to enable or disable IPv4 PXE boot support. If disabled, IPv4 PXE boot support will not be available.

IPv4 HTTP Support

Use this to enable or disable IPv4 HTTP boot support. If disabled, IPv4 HTTP boot support will not be available.

IPv6 PXE Support

Use this to enable or disable IPv6 PXE boot support. If disabled, IPv6 PXE boot support will not be available.

IPv6 HTTP Support

Use this to enable or disable IPv6 HTTP boot support. If disabled, IPv6 HTTP boot support will not be available.

PXE boot wait time

Wait time in seconds to press ESC key to abort the PXE boot. Use either +/- or numeric keys to set the value.

Media detect count

Number of times the presence of media will be checked. Use either +/- or numeric keys to set the value.

3.3.11 Intel VMD technology

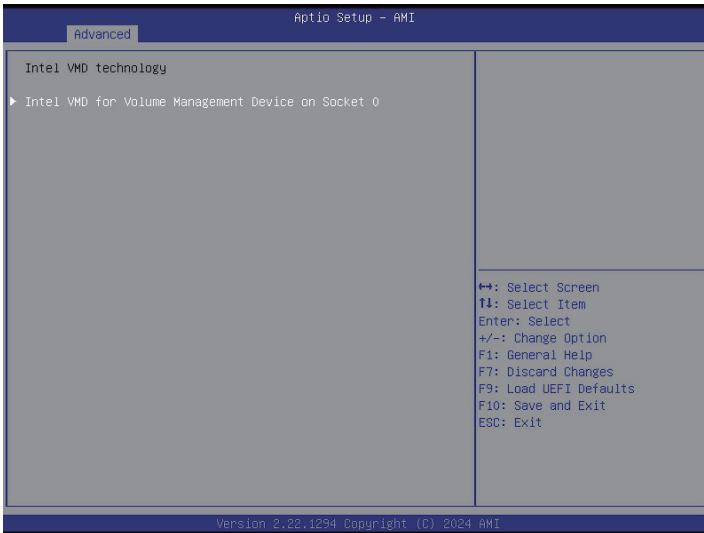

Press <Enter> to bring up the Intel VMD for Volume Management Device Configuration menu.

Intel VMD for Volume Management Device on Socket 0

When [Enabled], users are allowed to configure the options below.

Enable/Disable VMD

Use this item to enable or disable VMD in this Stack.

VMD port X

Use this item to enable or disable Intel(R) Volume Management Device Technology on specific root port.

3.3.12 Driver Health

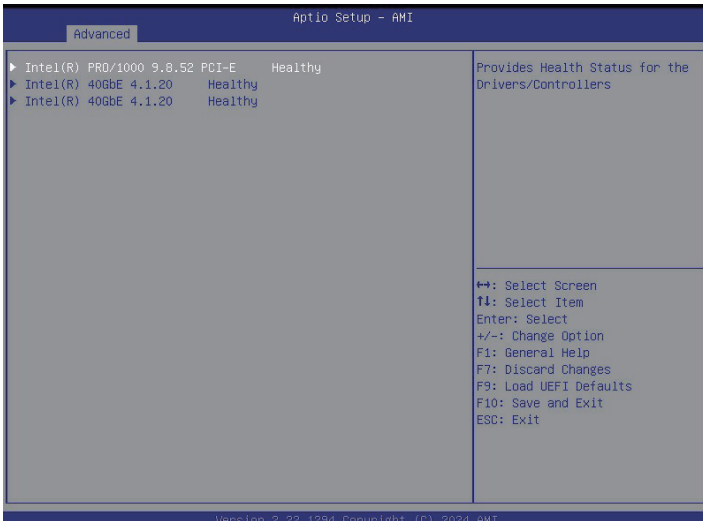

This displays the Health Status for the Drivers/Controllers.

3.3.13 Tls Auth Configuration



Server CA Configuration

Press <Enter> to configure Server CA.

Client Cert Configuration

Enroll Cert

Press <Enter> to enroll cert.

Delete Cert

Press <Enter> to delete cert.

3.3.14 Instant Flash

Instant Flash is a UEFI flash utility embedded in Flash ROM. This convenient UEFI update tool allows user to update system UEFI without entering operating systems first like MSDOS or Windows®. Just save the new UEFI file to the USB flash drive, floppy disk or hard drive and launch this tool, then update the UEFI only in a few clicks without preparing an additional floppy diskette or other complicated flash utility. Please be noted that the USB flash drive or hard drive must use FAT32/16/12 file system. Execute the Instant Flash utility, the utility will show the UEFI files and the respective information. Select the proper UEFI file to update UEFI, and reboot the system after the UEFI update process is completed.

3.4 Server Mgmt



Wait For BMC

Wait For BMC response for specified time out. BMC starts at the same time when BIOS starts during AC power ON. It takes around 255 seconds to initialize Host to BMC interfaces.

FRB-2 Timer

Use this item to enable or disable FRB-2 timer (POST timer)

FRB-2 Timer Timeout

Use this to define the FRB-2 Time Expiration between 1 to 30 value.

FRB-2 Timer Policy

Configure how the system should respond. If the FRB-2 Timer expires is disabled, this item is not available.

OS Watchdog Timer

Use this item to enable or disable OS Watchdog Timer. If enabled, starts a BIOS timer which can only be shut off by Management Software after the OS loads.

OS Wtd Timer Timeout

Configure the OS Boot Watchdog Timer Expiration between 1 to 30 min value. If the OS Boot Watchdog Timer is disabled, this item is not available.

OS Wtd Timer Policy

Configure how the system should respond if the OS Boot Watchdog Timer expires. If the OS Boot Watchdog Timer is disabled, this item is not available.

BMC Network Configuration

Use this to configure BMC network parameters.

DNS Configuration

Use this to configure DNS parameters.

System Event Log

Press <Enter> to change the SEL event log configuration.

BMC Tools

Use this item to configure about KCS control, restore AC power loss and load BMC default settings.

3.4.1 BMC Network Configuration

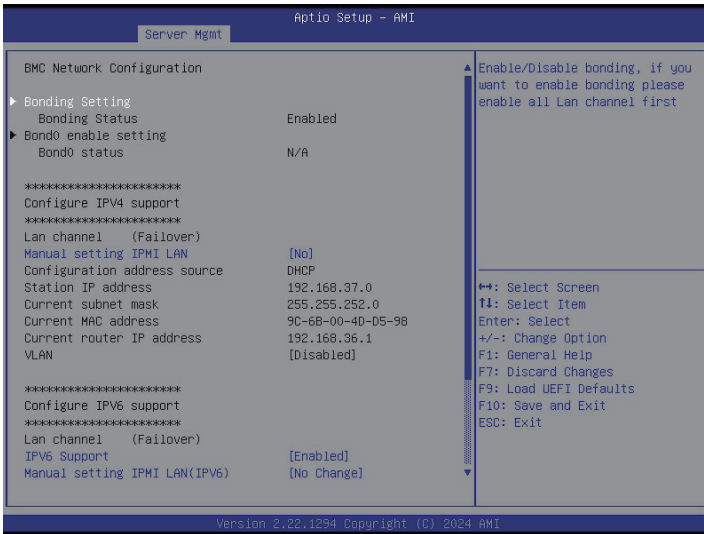

Bonding Setting

Select this item to enabled or disabled bonding. Please enable all lan channel first when want to enable bonding.

Manual Setting IPMI LAN

If [No] is selected, the IP address is assigned by DHCP. If using a static IP address, toggle to [Yes], and the changes take effect after the system reboots. The default value is [No].

Configuration Address Source

Select to configure BMC network parameters statically or dynamically(by BIOS or BMC). Configuration options: [Static] and [DHCP].

Static: Manually enter the IP Address, Subnet Mask and Gateway Address in the BIOS for BMC LAN channel configuration.

DHCP: IP address, Subnet Mask and Gateway Address are automatically assigned by the network's DHCP server.



The default login information for the IPMI web interface is:

Username: admin

Password: admin

For more instructions on how to set up remote control environment and use the IPMI management platform, please refer to the IPMI Configuration User Guide or go to the Support website at: <http://www.asrockrack.com/support/faq.asp>

VLAN

Enable or disable Virtual Local Area Network.

If [Enabled] is selected, configure the items below.

VLAN ID: Select this item to configure the VLAN ID setting, the Maximum value is 4094 and the Minimum value is 1.

VLAN Priority: Select this item to configure the VLAN Priority setting, the Maximum value is 7 and the Minimum value is 0.

IPv6 Support

Enable or disable LAN IPv6 Support.

Manual Setting IPMI LAN(IPV6)

Select to configure LAN channel parameters statically or dynamically(by BIOS or BMC).

Unspecified option will not modify any BMC network parameters during BIOS phase.

3.4.2 DNS Configuration

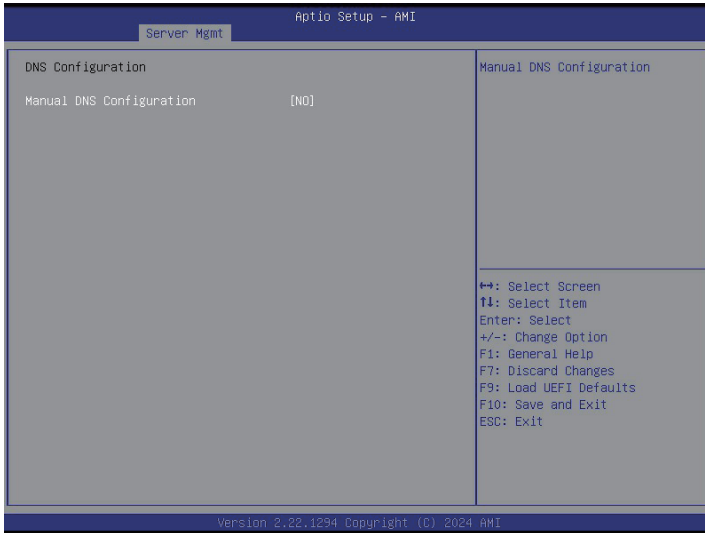

Manual DNS Configuration

Select this item to manual configure DNS.

If [YES] is selected, configure the items below.

DNS Service

Use this item to enable or disable DNS Service Configuration.

Host Name Settings

Use this item to automatic or manual Host Name Settings.

Bond Register BMC

Use this item to enable or disable Bond Register BMC.

Domain Setting

This item supports Manual, Bond0_v4 and Bond0_v6 Domain Settings.

Domain Name Server Setting

This item supports Manual and Bond0 DNS Server Settings.

IP Priority

This item supports IPV4 and IPV6 IP Priority.

3.4.3 System Event Log



SEL Components

Change this to enable or disable event logging for error/progress codes during boot.

Erase SEL

Use this to choose options for erasing SEL.

When SEL is Full

Use this to choose options for reactions to a full SEL.

Log EFI Status Codes

Use this item to disable the logging of EFI Status Codes or log only error code or only progress code or both.

PCIe Device Degrade ELog Support

Use this item to enable or disable PCIe Device Degrade Error Logging Support.

3.4.4 BMC Tools

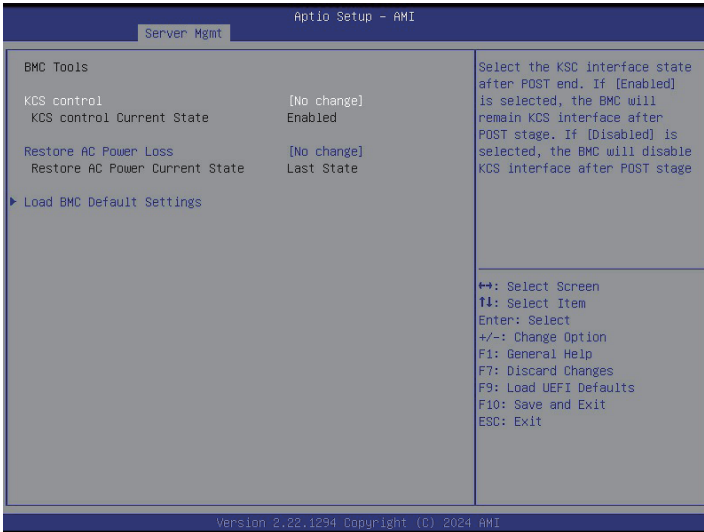

KCS Control

Select this KCS interface state after POST end. If [Enabled] is selected, the BMC will remain KCS interface after POST stage. If [Disabled] is selected, the BMC will disable KCS interface after POST stage

Restore AC Power Loss

This allows user to set the power state after an unexpected AC/power loss. If [Power Off] is selected, the AC/power remains off when the power recovers. If [Power On] is selected, the AC/power resumes and the system starts to boot up when the power recovers. If [Last State] is selected, it will recover to the state before AC/power loss.

Load BMC Default Settings

Use this item to Load BMC Default Settings

3.5 Event Logs

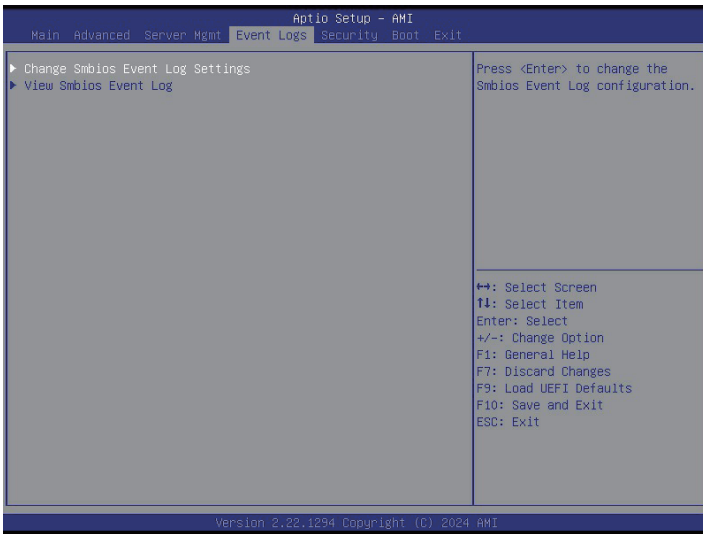

Change Smbios Event Log Settings

Use this item to configure the Smbios Event Log Settings.

When entering the item, the screen displays following sub-items:

Smbios Event Log

Use this item to enable or disable all features of the SMBIOS Event Logging during system boot.

Erase Event Log

Choose options for erasing Smbios Event Log. Erasing is done prior to any logging activation during reset.

When Log is Full

Use this item to choose options for reactions to a full Smbios Event Log. The options include [Do Nothing] and [Erase Immediately].

Log System Boot Event

Choose option to enable/disable logging of System boot event.

View Smbios Event Log

Press <Enter> to view the Smbios Event Log records.



All values changed here do not take effect until computer is restarted.

3.6 Security

This section allows user to set or change the supervisor/user password for the system. For the user password item is allowed user to clear it.



Supervisor Password

Set or change the password for the administrator account. Only the administrator has authority to change the settings in the UEFI Setup Utility. Leave it blank and press enter to remove the password.

User Password

Set or change the password for the user account. Users are unable to change the settings in the UEFI Setup Utility. Leave it blank and press enter to remove the password.

Secure Boot

Secure Boot feature is Active if Secure Boot is Enabled, Platform Key(PK) is enrolled and the System is in User mode. The mode change requires platform reset.

Secure Boot Mode

Secure Boot mode selector: Standard/Custom. In Custom mode Secure Boot Variables can be configured without authentication.

3.6.1 Expert Key Management

In this section, expert users can modify Secure Boot Policy variables without full authentication.

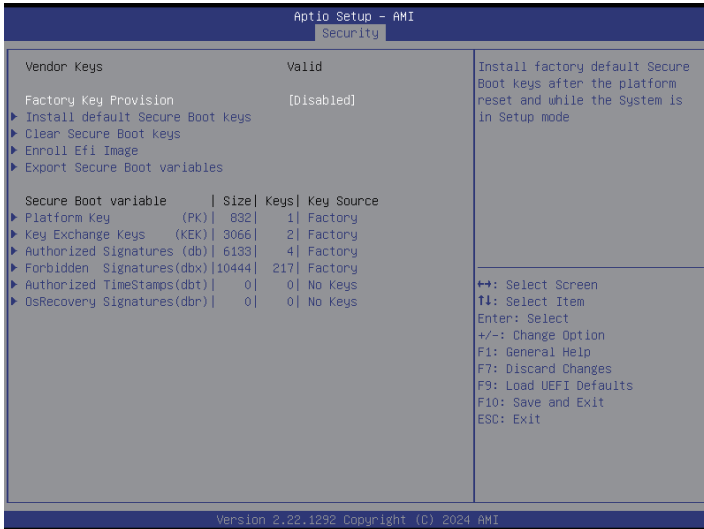

Factory Key Provision

Install factory default Secure Boot keys after the platform reset and while the System is in Setup mode.

Install Default Secure Boot Keys

Please install default secure boot keys if it's the first time to use secure boot.

Clear Secure Boot Keys

This force system to setup Mode-Clear all Secure Boot Variables. Change takes effect after reboot.

Enroll Efi Image

Allow the image to run in Secure Boot mode. Enroll SHA256 hash of the binary into Authorized Signature Database (db).

Export Secure Boot Variables

Copy NVRAM content of Secure Boot variables to files in a root folder on a file system device.

Platform Key (PK)

Enroll Factory Defaults or load certificates from a file:

1. Public Key Certificate in:

- a) EFI_SIGNATURE_LIST
- b) EFI_CERT_X509 (DER)
- c) EFI_CERT_RSA2048 (bin)
- d) EFI_CERT_SHAXXX

2. Authenticated UEFI Variable

3. EFI PE/COFF Image(SHA256)

Key Source: Factory, Modified, Mixed

Key Exchange Keys (KEK)

Enroll Factory Defaults or load certificates from a file:

1. Public Key Certificate in:

- a) EFI_SIGNATURE_LIST
- b) EFI_CERT_X509 (DER)
- c) EFI_CERT_RSA2048 (bin)
- d) EFI_CERT_SHAXXX

2. Authenticated UEFI Variable

3. EFI PE/COFF Image(SHA256)

Key Source: Factory, Modified, Mixed

Authorized Signatures (db)

Enroll Factory Defaults or load certificates from a file:

1. Public Key Certificate in:

- a) EFI_SIGNATURE_LIST
- b) EFI_CERT_X509 (DER)
- c) EFI_CERT_RSA2048 (bin)
- d) EFI_CERT_SHAXXX

2. Authenticated UEFI Variable
3. EFI PE/COFF Image(SHA256)

Key Source: Factory, Modified, Mixed

Forbidden Signatures (dbx)

Enroll Factory Defaults or load certificates from a file:

1. Public Key Certificate in:

- a) EFI_SIGNATURE_LIST
- b) EFI_CERT_X509 (DER)
- c) EFI_CERT_RSA2048 (bin)
- d) EFI_CERT_SHAXXX

2. Authenticated UEFI Variable
3. EFI PE/COFF Image(SHA256)

Key Source: Factory, Modified, Mixed

Authorized TimeStamps (dbt)

Enroll Factory Defaults or load certificates from a file:

1. Public Key Certificate in:

- a) EFI_SIGNATURE_LIST
- b) EFI_CERT_X509 (DER)
- c) EFI_CERT_RSA2048 (bin)
- d) EFI_CERT_SHAXXX

2. Authenticated UEFI Variable
3. EFI PE/COFF Image(SHA256)

Key Source: Factory, Modified, Mixed

OsRecovery Signatures (dbr)

Enroll Factory Defaults or load certificates from a file:

1. Public Key Certificate in:

- a) EFI_SIGNATURE_LIST

- b) EFI_CERT_X509 (DER)
 - c) EFI_CERT_RSA2048 (bin)
 - d) EFI_CERT_SHAXXX
2. Authenticated UEFI Variable
 3. EFI PE/COFF Image(SHA256)

Key Source: Factory, Modified, Mixed

3.7 Boot Screen

In this section, it will display the available devices on the system for user to configure the boot settings and the boot priority.

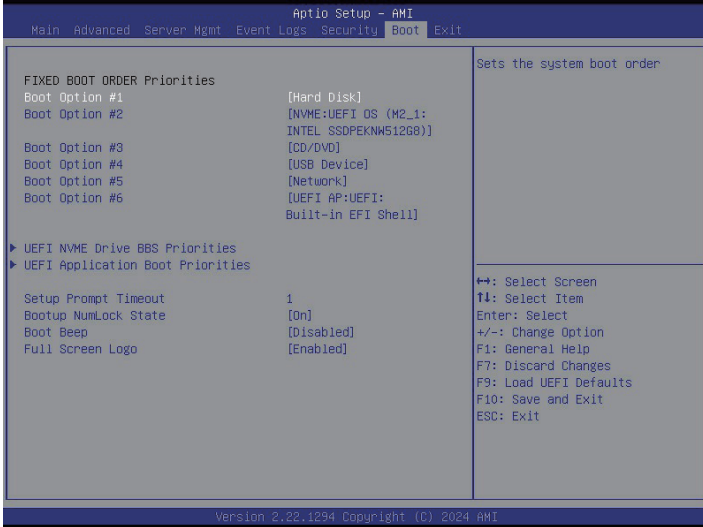

Boot Option #1/#2/#3/#4/#5/#6

Use this to set the system boot order.

UEFI USB Drive BBS Priorities

Specifies the Boot Device Priority sequence from available UEFI USB Drives.

UEFI Application Boot Priorities

Specifies the Boot Device Priority sequence from available UEFI Application.

Setup Prompt Timeout

Configure the number of seconds to wait for the UEFI setup utility.

Bootup NumLock State

Select whether Num Lock should be turned on or off when the system boots up.

Boot Beep

Select whether the Boot Beep should be turned on or off when the system boots up. Please note that a buzzer is needed.

Full Screen Logo

Enable to display the boot logo or disable to show normal POST message.

3.8 Exit Screen

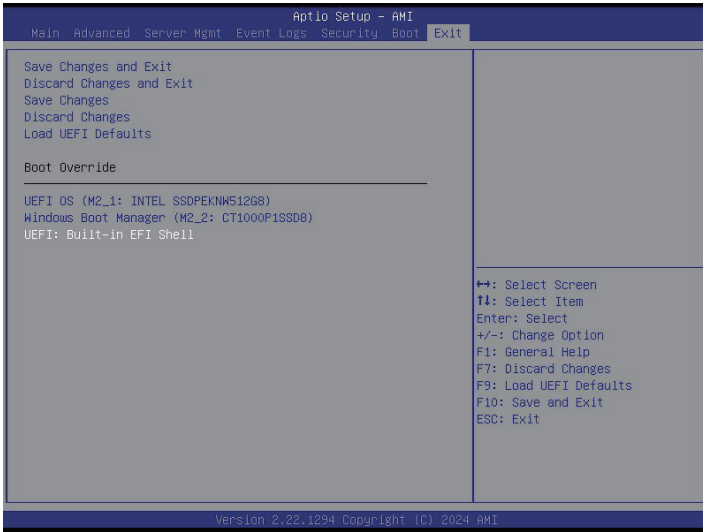

Save Changes and Exit

When selecting this option, the following message “Save configuration changes and exit setup?” will pop-out. Press <F10> key or select [Yes] to save the changes and exit the UEFI SETUP UTILITY.

Discard Changes and Exit

When selecting this option, the following message “Discard changes and exit setup?” will pop-out. Press <ESC> key or select [Yes] to exit the UEFI SETUP UTILITY without saving any changes.

Save Changes

When selecting this option, the following message “Save changes?” will pop-out. Select [Yes] to save all changes.

Discard Changes

When selecting this option, the following message “Discard changes?” will pop-out. Select [Yes] to discard all changes.

Load UEFI Defaults

Use this item to restore or load default values for all the setup options.

Chapter 4 Software Support

After all the hardware has been installed, it suggests to go to the official website at <http://www.ASRockRack.com> and make sure if there are any new updates of the BIOS / BMC firmware for the motherboard.

4.1 Download and Install Operating System

This motherboard supports various Microsoft® Windows® Server / Linux compliant operating systems. Please download the operating system from the OS manufacturer. Please refer to the OS documentation for more instructions.

**Please download the Intel® Rapid Storage Technology driver from the ASRock Rack's website (www.asrockrack.com) to the USB drive while installing OS in SATA RAID mode.*

4.2 Download and Install Software Drivers

This motherboard supports various Microsoft® Windows® compliant drivers. Please download the required drivers from the website at <http://www.ASRockRack.com>.

To download necessary drivers, go to the product page, click on the "Download" tab, choose the operating system that is used, and then download the using driver.

Chapter 5 Troubleshooting

5.1 Troubleshooting Procedures

Follow the procedures below to troubleshoot the system.



Always unplug the power cord before adding, removing or changing any hardware components. Failure to do so may cause physical injuries and damages to motherboard components.

1. Disconnect the power cable and check whether the PWR LED is off.
2. Unplug all cables, connectors and remove all add-on cards from the motherboard. Make sure that the jumpers are set to default settings.
3. Confirm that there are no short circuits between the motherboard and the chassis.
4. Install a CPU and fan on the motherboard, then connect the chassis speaker and power LED.

If there is no power...

1. Confirm that there are no short circuits between the motherboard and the chassis.
2. Make sure that the jumpers are set to default settings.
3. Check the settings of the 115V/230V switch on the power supply.
4. Verify if the battery on the motherboard provides ~3VDC. Install a new battery if it does not.

If there is no video...

1. Try replugging the monitor cables and power cord.
2. Check for memory errors.

If there are memory errors...

1. Verify that the DIMM modules are properly seated in the slots.
2. Use recommended DDR5 RDIMM/MRDIMM.
3. Install more than one DIMM modules that should be identical with the same brand, speed, size and chip-type.
4. Try inserting different DIMM modules into different slots to identify faulty ones.
5. Check the settings of the 115V/230V switch on the power supply.

Unable to save system setup configurations...

1. Verify if the battery on the motherboard provides ~3VDC. Install a new battery if it does not.
2. Confirm whether the power supply provides adequate and stable power.

Other problems...

1. Try searching keywords related to the related problem on ASRock Rack's FAQ page:
<http://www.asrockrack.com/support>

5.2 Technical Support Procedures

If the problems are still unsolved, please contact ASRock Rack's technical support with the following information:

1. Contact information
2. Model name, BIOS version and problem type.
3. System configuration.
4. Problem description.

Contact ASRock Rack's technical support at:
<http://www.asrockrack.com/support/tsd.asp>

5.3 Returning Merchandise for Service

For warranty service, the receipt or a copy of the invoice marked with the date of purchase is required. By calling the vendor or going to RMA website (<http://event.asrockrack.com/tsd.asp>) to obtain a Returned Merchandise Authorization (RMA) number.

The RMA number should be displayed on the outside of the shipping carton which is mailed prepaid or hand-carried when returning the motherboard to the manufacturer. Shipping and handling charges will be applied for all orders that must be mailed when service is complete.

This warranty does not cover damages incurred in shipping or from failure due to alteration, misuse, abuse or improper maintenance of products.

Contact the distributor first for any product related problems during the warranty period.

Contact Information

If it needs to contact ASRock Rack or want to know more about ASRock Rack, you're welcome to visit ASRock Rack's website at <http://www.asrockrack.com>; or contact the dealer for further information. For technical questions, please submit a support request form at <https://event.asrockrack.com/tsd.asp>

ASRock Rack Incorporation

e-mail: ASRockRack_sales@asrockrack.com

ASRock Rack Europe B.V.

Bijsterhuizen 11-11

6546 AR Nijmegen

The Netherlands

Phone: +31-24-345-44-33

ASRock Rack America Inc.

4331 Eucalyptus Ave., Chino, CA 91710 U.S.A.

Phone: +1-909-590-8308

Fax: +1-909-590-1026