



RS700A-E12 Series

RS700A-E12-RS12U

1U Rackmount Server User Guide



Copyright © 2025 ASUSTeK COMPUTER INC. All Rights Reserved.

No part of this manual, including the products and software described in it, may be reproduced, transmitted, transcribed, stored in a retrieval system, or translated into any language in any form or by any means, except documentation kept by the purchaser for backup purposes, without the express written permission of ASUSTeK COMPUTER INC. ("ASUS").

ASUS provides this manual "as is" without warranty of any kind, either express or implied, including but not limited to the implied warranties or conditions of merchantability or fitness for a particular purpose. In no event shall ASUS, its directors, officers, employees, or agents be liable for any indirect, special, incidental, or consequential damages (including damages for loss of profits, loss of business, loss of use or data, interruption of business and the like), even if ASUS has been advised of the possibility of such damages arising from any defect or error in this manual or product.

Specifications and information contained in this manual are furnished for informational use only, and are subject to change at any time without notice, and should not be construed as a commitment by ASUS. ASUS assumes no responsibility or liability for any errors or inaccuracies that may appear in this manual, including the products and software described in it.

Product warranty or service will not be extended if: (1) the product is repaired, modified or altered, unless such repair, modification or alteration is authorized in writing by ASUS; or (2) the serial number of the product is defaced or missing.

Products and corporate names appearing in this manual may or may not be registered trademarks or copyrights of their respective companies, and are used only for identification or explanation and to the owners' benefit, without intent to infringe.

Contents

Safety information.....	vii
About this guide.....	ix

Chapter 1: Product Introduction

1.1	System package contents.....	1-2
1.2	Serial number label.....	1-3
1.3	System specifications	1-4
1.4	Front panel features.....	1-7
1.5	Rear panel features.....	1-8
1.6	Internal features	1-9
1.7	LED information	1-10
1.7.1	Front panel LEDs	1-10
1.7.2	Storage device status LED.....	1-11
1.7.3	LAN (RJ45) LEDs.....	1-12
1.7.4	Rear panel LEDs.....	1-12
1.7.5	Q-Code table.....	1-13

Chapter 2: Hardware Information

2.1	Chassis cover.....	2-2
2.1.1	Removing the rear cover.....	2-2
2.1.2	Removing the backplane cover.....	2-3
2.2	Air duct(s).....	2-4
2.2.1	Removing the air duct(s).....	2-4
2.2.2	Installing the air duct(s).....	2-5
2.3	Central Processing Unit (CPU)	2-6
2.3.1	Installing the CPU	2-7
2.3.2	Installing the heatsink.....	2-10
2.4	System memory	2-12
2.4.1	Overview	2-12
2.4.2	Memory Configurations.....	2-13
2.4.3	Installing a DIMM	2-15
2.4.4	Removing a DIMM	2-15
2.5	(optional) Front bezel.....	2-16
2.5.1	Removing the front bezel.....	2-16
2.5.2	Installing the front bezel.....	2-17
2.6	Storage devices.....	2-18

Contents

- 2.7 Expansion slots.....2-20**
 - 2.7.1 Installing an expansion card to the PCIe riser card bracket..... 2-21
 - 2.7.2 Installing an OCP 3.0 card 2-24
 - 2.7.3 Installing an expansion card to the butterfly riser card bracket 2-25
 - 2.7.4 Installing an ethernet expansion card to the butterfly riser card bracket 2-27
 - 2.7.5 Installing an HBA/RAID card to the butterfly riser card bracket 2-28
 - 2.7.6 Removing the HBA/RAID card from the butterfly riser card bracket 2-30
 - 2.7.7 Installing the Cache Vault Power Module 2-31
 - 2.7.8 Installing an M.2 (NGFF) card..... 2-32
 - 2.7.9 Configuring an expansion card 2-33
- 2.8 Cable connections2-34**
- 2.9 Backplane cabling2-35**
- 2.10 Storage device configuration and cabling2-36**
 - 2.10.1 12 x SATA/NVMe storage device configuration and cabling 2-37
 - 2.10.2 4 x NVMe storage device configuration and cabling 2-39
 - 2.10.3 8 x NVMe storage device configuration and cabling 2-42
 - 2.10.4 12 x NVMe storage device configuration and cabling 2-45
 - 2.10.5 8 x SAS and 4 x SATA storage device configuration and cabling..... 2-48
- 2.11 Motherboard2-51**
 - 2.11.1 Removing the motherboard..... 2-51
 - 2.11.2 Installing the motherboard..... 2-52
- 2.12 Removable/optional components.....2-53**
 - 2.12.1 System fans 2-53
 - 2.12.2 Redundant power supply module 2-57
 - 2.12.3 CMOS battery 2-58
- 2.13 Rail Kit Options2-59**

Chapter 3: Motherboard Information

- 3.1 Motherboard layout.....3-2**
- 3.2 Central Processing Unit (CPU)3-5**
- 3.3 Dual Inline Memory Module (DIMM).....3-5**
- 3.4 Jumpers3-6**
- 3.5 Internal LEDs.....3-10**

Contents

3.6	Internal connectors.....	3-12
------------	---------------------------------	-------------

Chapter 4: BIOS Setup

4.1	Managing and updating your BIOS	4-2
4.1.1	ASUS CrashFree BIOS 3 utility.....	4-2
4.1.2	ASUS EZ Flash Utility	4-3
4.2	BIOS setup program	4-4
4.2.1	BIOS menu screen.....	4-5
4.2.2	Menu bar	4-5
4.2.3	Menu items.....	4-6
4.2.4	Submenu items	4-6
4.2.5	Navigation keys.....	4-6
4.2.6	General help.....	4-6
4.2.7	Configuration fields	4-6
4.2.8	Pop-up window.....	4-6
4.2.9	Scroll bar	4-6
4.3	Main menu	4-7
4.4	Performance Tuning menu.....	4-8
4.5	Advanced menu	4-10
4.5.1	Trusted Computing.....	4-10
4.5.2	Redfish Host Interface Settings.....	4-11
4.5.3	AMD CBS.....	4-11
4.5.4	Onboard LAN Configuration.....	4-21
4.5.5	Serial Port Console Redirection	4-22
4.5.6	CPU Configuration	4-24
4.5.7	PCI Subsystem Settings	4-25
4.5.8	USB Configuration	4-30
4.5.9	Network Stack Configuration.....	4-31
4.5.10	NVMe Configuration.....	4-32
4.5.11	SATA Configuration	4-33
4.5.12	APM Configuration	4-33
4.5.13	AMD Mem Configuration Status.....	4-34
4.5.14	T1s Auth.....	4-34
4.5.15	Driver Health	4-35
4.5.16	Third-party UEFI driver configurations	4-35
4.6	Chipset menu	4-36
4.7	Security menu	4-37

Contents

- 4.8 Boot menu 4-41**
- 4.9 Tool menu 4-42**
- 4.10 Event Logs menu 4-43**
 - 4.10.1 Change Smbios Event Log Settings 4-44
 - 4.10.2 View Smbios Event Log 4-45
- 4.11 Server Mgmt menu 4-46**
 - 4.11.1 System Event Log 4-47
 - 4.11.2 BMC network configuration 4-48
 - 4.11.3 View System Event Log 4-50
- 4.12 Exit menu 4-51**

Appendix

- K14PP-D24 block diagram A-2**
- Notices A-3**
- Service and Support A-8**

Safety information

Electrical Safety

- Before installing or removing signal cables, ensure that the power cables for the system unit and all attached devices are unplugged.
- To prevent electrical shock hazard, disconnect the power cable from the electrical outlet before relocating the system.
- When adding or removing any additional devices to or from the system, ensure that the power cables for the devices are unplugged before the signal cables are connected. If possible, disconnect all power cables from the existing system before you add a device.
- If the power supply is broken, do not try to fix it by yourself. Contact a qualified service technician or your dealer.

Operation Safety

- Any mechanical operation on this server must be conducted by certified or experienced engineers.
- Before operating the server, carefully read all the manuals included with the server package.
- Before using the server, ensure all cables are correctly connected and the power cables are not damaged. If any damage is detected, contact your dealer as soon as possible.
- To avoid short circuits, keep paper clips, screws, and staples away from connectors, slots, sockets and circuitry.
- Avoid dust, humidity, and temperature extremes. Place the server on a stable surface.
- If you encounter technical problems with the product, contact a qualified service technician or your retailer.



This product is equipped with a three-wire power cable and plug for the user's safety. Use the power cable with a properly grounded electrical outlet to avoid electrical shock.

Restricted Access Location

This equipment should only be installed in a Restricted Access Area where both these conditions apply:

- Access can only be gained by skilled or instructed persons who have been instructed about the reasons for the restrictions applied to the area and about any precautions that shall be taken; and
- Access is through the use of a TOOL, or other means of security, and is controlled by the authority responsible for the area.

Lithium-Ion Battery Warning

CAUTION! Danger of explosion if battery is incorrectly replaced. Replace only with the same or equivalent type recommended by the manufacturer. Dispose of used batteries according to the manufacturer's instructions.

Heavy System

CAUTION! This server system is heavy. Ask for assistance when moving or carrying the system.

Optical Drive Safety Information

Laser Safety Information



To prevent exposure to the optical drive's laser, do not attempt to disassemble or repair the optical drive by yourself. For your safety, contact a professional technician for assistance.

About this guide

Audience

This user guide is intended for system integrators, and experienced users with at least basic knowledge of configuring a server.

Contents

This guide contains the following parts:

1. Chapter 1: Product Introduction

This chapter describes the general features of the server, including sections on front panel and rear panel specifications.

2. Chapter 2: Hardware Information

This chapter lists the hardware setup procedures that you have to perform when installing or removing system components.

3. Chapter 3: Motherboard Information

This chapter gives information about the motherboard that comes with the server. This chapter includes the motherboard layout, jumper settings, and connector locations.

4. Chapter 4: BIOS Setup

This chapter tells how to change system settings through the BIOS Setup menus and describes the BIOS parameters.

Conventions

To ensure that you perform certain tasks properly, take note of the following symbols used throughout this manual.



DANGER/WARNING: Information to prevent injury to yourself when trying to complete a task.



CAUTION: Information to prevent damage to the components when trying to complete a task.



IMPORTANT: Instructions that you **MUST** follow to complete a task.



NOTE: Tips and additional information to help you complete a task.

Typography

Bold text

Indicates a menu or an item to select.

Italics

Used to emphasize a word or a phrase.

<Key>

Keys enclosed in the less-than and greater-than sign means that you must press the enclosed key.

Example: <Enter> means that you must press the Enter or Return key.

<Key1>+<Key2>+<Key3>

If you must press two or more keys simultaneously, the key names are linked with a plus sign (+).

Example: <Ctrl>+<Alt>+

Command

Means that you must type the command exactly as shown, then supply the required item or value enclosed in brackets.

Example: At the command prompt, type the command line: **format A:/S**

References

Refer to the following sources for additional information and for product and software updates.

1. **ASUS Control Center (ACC) user guide**

This manual tells how to set up and use the proprietary ASUS server management utility. Visit asuscontrolcenter.asus.com for more information.

2. **ASUS websites**

The ASUS websites worldwide provide updated information for all ASUS hardware and software products. Refer to the ASUS contact information.

Product Introduction

1

This chapter describes the general features of the server. It includes sections on front panel and rear panel specifications.

1.1 System package contents

Check your system package for the following items.

RS700A-E12-RS12U	
Chassis	ASUS 1U Rackmount Chassis
Motherboard	ASUS K14PP-D24 Server Board
Components	1 x 80PLUS Power Supply 1 x 2.5-inch Storage Device Backplane 12 x 2.5-inch Storage Device Trays or Dummy Trays 1 x Front Panel Board 2 x Riser Cards 8 x System Fans
Accessories	1 x Bag of Screws 2 x CPU Heatsinks 2 x AC Power Cables
Optional Items	1 x 80PLUS Power Supply (Second PSU) 1 x Friction Rail Kit or Ball Bearing Rail Kit (1000/1200mm)



- If any of the above items is damaged or missing, contact your retailer.
- Optional items come bundled if you selected them when purchasing the system and cannot be bought separately.

1.2 Serial number label

The product's serial number contains 12 characters, such as xxSxxxxxxxxx, and printed on the sticker adhered to the server's front cover.

The correct serial number of the product is required if you need to request for support from the ASUS Technical Support team.

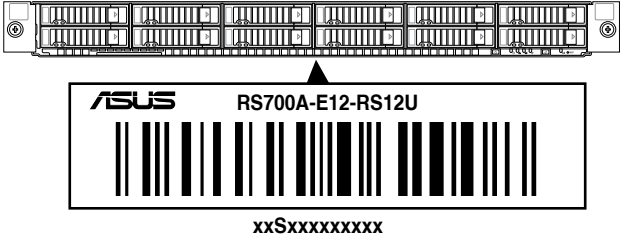

1.3 System specifications

The ASUS RS700A-E12 Series features the ASUS K14PP-D24 server board. The server supports AMD EPYC™ 9004 series processors.

Model Name		RS700A-E12-RS12U
Motherboard		K14PP-D24
Processor Support		2 x Socket SP5 (LGA 6096) AMD EPYC™ 9004 series (up to 400W)
Memory	Total Slots	24 (12-channel per CPU, 1 DIMM per channel)
	Capacity	Maximum up to 3TB per CPU socket
	Memory Type	DDR5 4800/4400 RDIMM / 3DS RDIMM * Please refer to www.asus.com for latest memory AVL update
	Memory Size	128GB, 64GB, 32GB RDIMM 128GB, 64GB, 32GB 3DS RDIMM * Refer to www.asus.com/support for more information
Expansion Slots	Total PCIe / HBA/RAID Slots	3+1
	Slot Type	Up to 3 PCIe Gen5 slots + 1 internal RAID slot 1 x PCIe x16 (Gen5 x16 link), FHFL (CPU1) 1 x PCIe x16 (Gen5 x16 link), FHFL (CPU1) or OCP3.0 (CPU1) 1 x PCIe Gen5 x16, LP (if PCIe M.2 is in use, it will operate at x8 link) (CPU2) 1 x PCIe Gen4 x8, LP internal
	M.2	2 x M.2 (up to 2280 from CPU1)
	Micro SD Card slot	1
Disk Controller	SATA Controller	8 x SATA 6Gb/s ports 2 x M.2 connectors (SATA 6Gb/s & PCI-E Gen4 x4 link)
	SAS Controller	<u>Optional kit(s):</u> Broadcom HBA CARD 9500-16i Broadcom MegaRAID 9540-8i Broadcom MegaRAID 9560-16i
Storage	Storage Bay	12 x 2.5" Hot-Swap Drive Bays: - 12 x NVMe/SAS*/SATA * SAS support only from optional SAS HBA/RAID card
	Backplane Connectors	6 x MCIO x8 (for 12 x NVMe) 3 x slimline SAS x4 (for SATA)
	Motherboard Onboard Connectors	2 x M.2 connectors 2 x MCIO (for NVMe) 2 x GenZ x16 (for NVMe)
	Default Cables	1 x MCIO to slimline SAS Cable (for SAS) 1 x slimline SAS to slimline SAS Cable * Bundled if SATA/SAS storage was selected

(continued on the next page)

Model Name		RS700A-E12-RS12U
	NVMe upgrade option	Supports 4 x NVMe: via 2 x MCIO cables* Supports 8 x NVMe: via 4 x MCIO cables* Supports 12 x NVMe: via 6 x MCIO cables* * Please refer to Asus server Upgrade Part List for the latest update
Networking		4 x 1Gbe (Intel® I350-AM4) RJ45 ports or 2 x 10Gbe (Intel® X710-AT2) RJ45 ports 1 x Management Port <u>Optional OCP 3.0 Adapter:</u> Up to 200Gb/s Ethernet / InfiniBand Adapter
VGA		Aspeed AST2600 64MB
Graphic		Up to 2 single slot GPUs or 1 dual slot GPU* * The external fan must be installed for dual slot GPU.
Front I/O Ports		-
Rear I/O Ports		2 x USB 3.2 Gen1 ports 1 x VGA port 1 x RJ45 Mgmt LAN port 4/2 x NIC ports* 1 x OCP 3.0 port (optional) * The number of NIC ports available depends on the LAN Controller card installed.
Switch/LED		<u>Front Switch/LED:</u> 1 x Power Switch (w/ LED) 1 x Reset Switch 1 x Location Switch (w/ LED) 1 x Message LED LAN 1/3 and 2/4 LED (on NIC module)* * The number of LAN LEDs available depends on the LAN Controller card installed. <u>Rear Switch/LED:</u> 1 x Port 80 LED (Q-Code) 1 x Power Switch w/ LED 1 x Location Switch w/ LED
Security Options		TPM-SPI PFR
OS Support		Windows® Server RedHat® Enterprise Linux SuSE® Linux Enterprise Server CentOS Ubuntu VMware * Please find the latest OS support from https://servers.asus.com/support/os.
Management Solution	Software	ASUS Control Center
	Out of Band Remote Management	On-Board ASMB11-iKVM for KVM-over-IP

(continued on the next page)

Model Name	RS700A-E12-RS12U
Regulatory Compliance	BSMI, CE, CB, FCC (Class A)
Dimension	842.5 mm x 449 mm x 43.85 mm (1U) 33.17" x 17.68" x 1.73"
Net Weight Kg	14.94 kg (CPU, DRAM & HDD not included)
Gross Weight Kg	19.94 kg (CPU, DRAM & HDD not included, Packing include)
Power Supply (different configuration by region)	1+1 Redundant 2600 W/1600 W 80 PLUS Titanium Power Supply or 1+1 Redundant 2000 W/1600 W 80 PLUS Platium Power Supply Rating: 100-127/220-240 Vac, 12 A/9.5 A (x2), 50/60 Hz 100-127/240 Vac, 13.8 A/16 A (x2), 50/60 Hz 220-240Vac, 10 A (x2), 50/60 Hz
Environment	Operating temperature: 10° ~ 35° Non-operating temperature: -40° ~ 60° Non-operating humidity: 20% ~ 90% (Non-condensing)

* Specifications are subject to change without notice.

1.4 Front panel features

The barebone server features a simple yet stylish front panel with easily accessible features. The power and reset buttons and LED indicators are located on the front panel.



Refer to the **LED information** section for the LED descriptions.

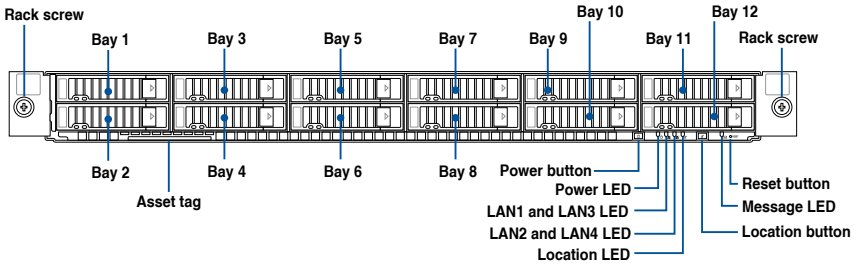

- Bays 1 to 12 support NVMe/SATA by default. SAS support requires optional HBA/RAID card.
- All bays support 2.5" drives with trays.

For extra security, a front bezel (purchased separately) can be installed to prevent unauthorized physical access to the hard drives and power button.

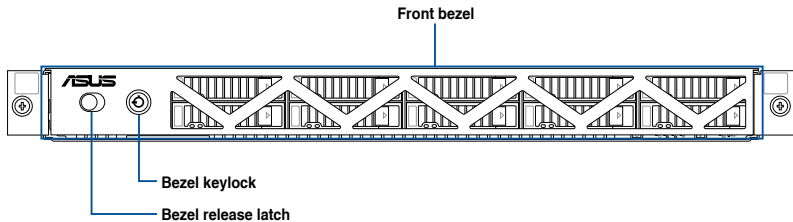

1.5 Rear panel features

The rear panel includes expansion slots and system power sockets. The middle part includes the I/O shield with openings for the rear panel connectors on the motherboard.

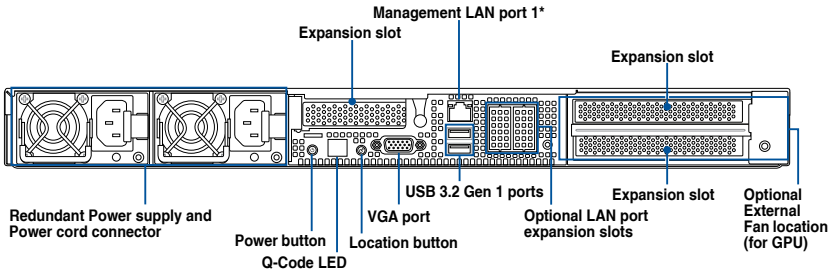

*This port is for ASUS ASMB11-iKVM only.

1.6 Internal features

The barebone server includes the basic components as shown.

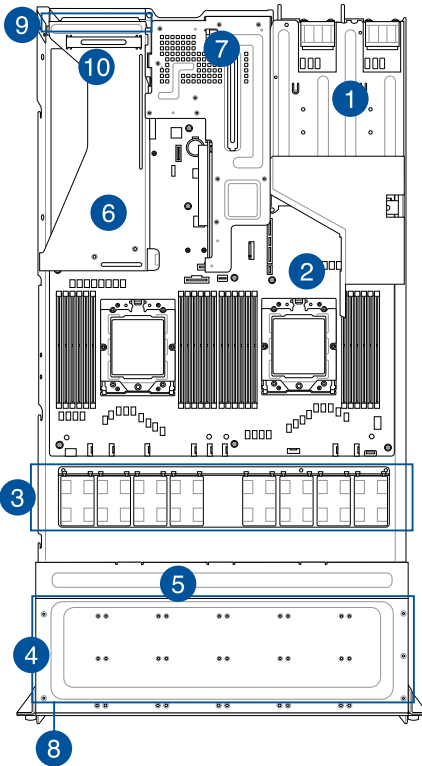

1. Redundant Power supply
2. ASUS K14PP-D24 Server Board
3. System fans
4. 12 x 2.5" storage device trays
5. NVMe/SATA/SAS backplane (hidden)
6. PCIe riser card (hidden)
7. Butterfly riser card
8. Asset tag (hidden)
9. External Fan (optional, for GPU)
10. OCP Module (hidden, optional)



A protection film is pre-attached to the front cover before shipping. Please remove the protection film before turning on the system for proper heat dissipation.

WARNING!

HAZARDOUS MOVING PARTS
KEEP FINGERS AND OTHER BODY PARTS AWAY

1.7 LED information

1.7.1 Front panel LEDs

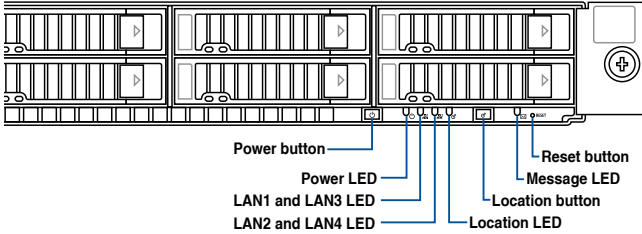

LED	Display status	Description
Power LED	ON	System power ON
Message LED	OFF ON	System is normal; no incoming event A hardware monitor event is indicated
Location LED	OFF ON	Normal status Location switch is pressed (Press the location switch again to turn off)
LAN LEDs	OFF Blinking ON	No LAN connection LAN is transmitting or receiving data LAN connection is present

1.7.2 Storage device status LED

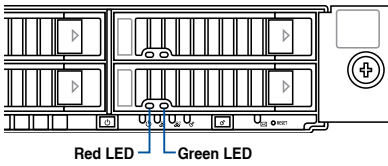

SATA/SAS Storage Device LED Description		
GREEN	ON	SATA/SAS storage device power ON
RED	ON	Storage device has failed and should be swapped immediately (For RAID card)
GREEN/ RED	Blinking	RAID rebuilding (For RAID card)
GREEN/ RED	Blinking	Locate (For RAID card)
GREEN/ RED	OFF	Storage device not found
GREEN	Blinking	Read/write data from/into the SATA/SAS storage device

1.7.3 LAN (RJ45) LEDs

Intel® I350-AM4 1GbE LAN port LEDs

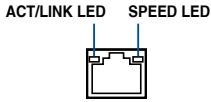

ACT / LINK LED	
Status	Description
OFF	No link
GREEN	Linked
BLINKING	Data activity

SPEED LED	
Status	Description
OFF	10Mbps connection
ORANGE	100 Mbps connection
GREEN	1 Gbps connection

Intel® X710-AT2 10GbE LAN port LEDs

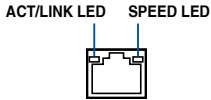

ACT / LINK LED	
Status	Description
OFF	No link
GREEN	Linked
BLINKING	Data activity

SPEED LED	
Status	Description
OFF	10Mbps / 100 Mbps connection
ORANGE	1 Gbps connection
GREEN	10 Gbps connection

1.7.4 Rear panel LEDs

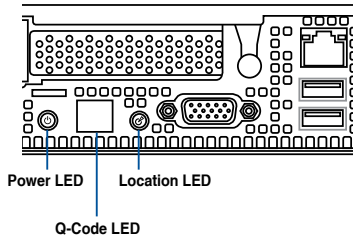

LED	Display status	Description
Power LED	ON	System power ON
Location LED	OFF	Normal status
	ON	Location switch is pressed (Press the location switch again to turn off)

1.7.5 Q-Code table

ACTION	PHASE	POST CODE	TYPE	DESCRIPTION
SEC Start up	Security Phase	0x01	Progress	First post code
		0x02	Progress	Load BSP microcode
		0x03	Progress	Perform early platform Initialization
		0x04	Progress	Set cache as ram for PEI phase
		0x05	Progress	Establish Stack
		0x06	Progress	CPU Early Initialization
PSP Boot	PSP Boot Loader phase (Error Post Codes)	0x00	error	General - Success
		0x01	error	Generic Error Code
		0x02	error	Generic Memory Error
		0x03	error	Buffer Overflow
		0x04	error	Invalid Parameter(s)
		0x05	error	Invalid Data Length
		0x06	error	Data Alignment Error
		0x07	error	Null Pointer Error
		0x08	error	Unsupported Function
		0x09	error	Invalid Service ID
		0x0A	error	Invalid Address
		0x0B	error	Out of Resource Error
		0x0C	error	Timeout
		0x0D	error	Data abort exception
		0x0E	error	Prefetch abort exception
		0x0F	error	Out of Boundary Condition Reached
		0x10	error	Data corruption
		0x11	error	Invalid command
		0x12	error	The package type provided by BR is incorrect
		0x13	error	Failed to retrieve FW header during FW validation
		0x14	error	Key size not supported
		0x15	error	Agesa0 verification error
		0x16	error	SMU FW verification error
		0x17	error	OEM SINGING KEY verification error
		0x18	error	Generic FW Validation error
		0x19	error	RSA operation fail - bootloader
		0x1A	error	CCP Passthrough operation failed - internal status
		0x1B	error	AES operation fail
		0x1C	error	CCP state save failed
		0x1D	error	CCP state restore failed
		0x1E	error	SHA256/384 operation fail - internal status
		0x1F	error	ZLib Decompression operation fail
		0x20	error	HMAC-SHA256/384 operation fail - internal status
		0x21	error	Booted from boot source not recognized by PSP
		0x22	error	PSP directory entry not found
		0x23	error	PSP failed to set the write enable latch
		0x24	error	PSP timed out because spirom took too long
		0x25	error	Cannot find BIOS directory
		0x26	error	SpiRom is not valid
		0x27	error	Slave die has different security state from master
		0x28	error	SMI interface init failure
		0x29	error	SMI interface generic error
0x2A	error	Invalid die ID executes MCM related function		
0x2B	error	Invalid MCM configuration table read from bootrom		
0x2C	error	Valid boot mode wasn't detected		
0x2D	error	NVStorage init failure		
0x2E	error	NVStorage generic error		
0x2F	error	MCM 'error' to indicate slave has more data to send		
0x30	error	MCM error if data size exceeds 32B		
0x31	error	Invalid client id for SVC MCM call		
0x32	error	MCM slave status register contains bad bits		
0x33	error	MCM call was made in a single die environment		
0x34	error	PSP secure mapped to invalid segment (should be 0x400_0000)		
0x35	error	No physical x86 cores were found on die		
0x36	error	Insufficient space for secure OS (range of free SRAM to SVC stack base)		
0x37	error	SYSHUB mapping memory target type is not supported		
0x38	error	Attempt to unmap permanently mapped TLB to PSP secure region		
0x39	error	Unable to map an SMN address to AXI space		
0x3A	error	Unable to map a SYSHUB address to AXI space		

ACTION	PHASE	POST CODE	TYPE	DESCRIPTION
PSP Boot	PSP Boot Loader phase (Error Post Codes)	0x3B	error	The count of CCXs or cores provided by bootrom is not consistent
		0x3C	error	Uncompressed image size doesn't match value in compressed header
		0x3D	error	Compressed option used in case where not supported
		0x3E	error	Fuse info on all dies don't match
		0x3F	error	PSP sent message to SMU; SMU reported an error
		0x40	error	Function RunPostX86ReleaseUnitTests failed in memcmp()
		0x41	error	Interface between PSP to SMU not available.
		0x42	error	Timer wait parameter too large
		0x43	error	Test harness module reported an error
		0x44	error	x86 wrote C2PMMSG_0 interrupting PSP, but the command has an invalid format
		0x45	error	Failed to read from SPI the Bios Directory or Bios Combo Directory
		0x46	error	Failed to find FW entry in SPL Table
		0x47	error	Failed to read the combo bios header
		0x48	error	SPL version mismatch
		0x49	error	Error in Validate and Loading AGESA APOB SVC call
		0x4A	error	Correct fuse bits for DIAG_BL loading not set
		0x4B	error	The UmcProgramKeys() function was not called by AGESA
		0x4C	error	Unconditional Unlock based on serial numbers failure
		0x4D	error	Syshub register programming mismatch during readback
		0x4E	error	Family ID in MPO_SFUSE_SEC[7:3] not correct
		0x4F	error	An operation was invoked that can only be performed by the GM
		0x50	error	Failed to acquire host controller semaphore to claim ownership of SMB
		0x51	error	Timed out waiting for host to complete pending transactions
		0x52	error	Timed out waiting for slave to complete pending transactions
		0x53	error	Unable to kill current transaction on host, to force idle
		0x54	error	One of: Illegal command, Unclaimed cycle, or Host time out
		0x55	error	An smbus transaction collision detected, operation restarted
		0x56	error	Transaction failed to be started or processed by host, or not completed
		0x57	error	An unsolicited smbus interrupt was received
		0x58	error	An attempt to send an unsupported PSP-SMU message was made
		0x59	error	An error/data corruption detected on response from SMU for sent msg
		0x5A	error	MCM Steady-state unit test failed
		0x5B	error	S3 Enter failed
		0x5C	error	AGESA BL did not set PSP SMU reserved addresses via SVC call
		0x5D	error	Reserved PSP/SMU memory region is invalid
		0x5E	error	CcxSecBisiEn not set in fuse RAM
		0x5F	error	RECEIVED an unexpected result
		0x60	error	VMG Storage Init failed
		0x61	error	Failure in mbedTLS user app
		0x62	error	An error occurred whilst attempting to SMN map a fuse register
		0x63	error	Fuse burn sequence/operation failed due to internal SOC error
		0x64	error	Fuse sense operation timed out
		0x65	error	Fuse burn sequence/operation timed out waiting for burn done
		0x66	error	The PMU FW Public key certificate loading or authentication fails
		0x67	error	This PSP FW was revoked
		0x68	error	The platform model/vendor id fuse is not matching the BIOS public key token
		0x69	error	The BIOS OEM public key of the BIOS was revoked for this platform
0x6A	error	PSP level 2 directory not match expected value.		
0x6B	error	BIOS level 2 directory not match expected value.		
0x6C	error	Reset image not found		
0x6D	error	Generic error indicating the CCP HAL initialization failed		
0x6E	error	Failure to copy NVRAM to DRAM.		
0x6F	error	Invalid key usage flag		
0x70	error	Unexpected fuse set		
0x71	error	RSMU signaled a security violation		
0x72	error	Error programming the WAFL PCS registers		
0x73	error	Error setting wafl PCS threshold value		
0x74	error	Error loading OEM trustlets		
0x75	error	Recovery mode across all dies is not sync'd		
0x76	error	Uncorrectable WAFL error detected		
0x77	error	Fatal MP1 error detected		
0x78	error	Bootloader failed to find OEM signature		
0x79	error	Error copying BIOS to DRAM		
0x7A	error	Error validating BIOS image signature		
0x7B	error	OEM Key validation failed		
0x7C	error	Platform Vendor ID and/or Model ID binding violation		

(continued on the next page)

ACTION	PHASE	POST CODE	TYPE	DESCRIPTION
PSP Boot	PSP Boot Loader phase (Status Post Codes)	0x7D	error	Bootloader detects BIOS request boot from SPI-ROM, which is unsupported for PSB.
		0x7E	error	Requested fuse is already blown, reblow will cause ASIC malfunction
		0x7F	error	Error with actual fusing operation
		0x80	error	(Local Master PSP on P1 socket) Error reading fuse info
		0x81	error	(Local Master PSP on P1 socket) Platform Vendor ID and/or Model ID binding violation
		0x82	error	(Local Master PSP on P1 socket) Requested fuse is already blown, reblow will cause ASIC malfunction
		0x83	error	(Local Master PSP on P1 socket) Error with actual fusing operation
		0x84	error	SEV FW Rollback attempt is detected
		0x85	error	SEV download FW command fail to broadcast and clear the lstrSRAM field on slave dies
		0x86	error	Agesa error injection failure
		0x87	error	Uncorrectable TWIX error detected
		0x88	error	Error programming the TWIX PCS registers
		0x89	error	Error setting TWIX PCS threshold value
		0x8A	error	SW CCP queue is full, cannot add more entries
		0x8B	error	CCP command description syntax error detected from input
		0x8C	error	Return value stating that the command has not yet be scheduled
		0x8D	error	The command is scheduled and being worked on
		0x8E	error	The DXIO PHY SRAM Public key certificate loading or authentication fails
		0x8F	error	TPM binary size exceeds limit allocated in Private DRAM, need to increase the limit
		0x90	error	The TWIX link for a particular CCD is not trained Fatal error
		0x91	error	Security check failed (not all dies are in same security state)
		0x92	error	FW type mismatch between the requested FW type and the FW type embedded in the FW binary header
		0x93	error	SVC call input parameter address violation
		0x94	error	Firmware Compatibility Level mismatch
		0x95	error	Bad status returned by I2CKnollCheck
		0x96	error	NACK to general call (no device on Knoll I2C bus)
		0x97	error	Null pointer passed to I2CKnollCheck
		0x98	error	Invalid device-ID found during Knoll authentication
		0x99	error	Error during Knoll/Prom key derivation
		0x9A	error	Null pointer passed to Crypto function
		0x9B	error	Error in checksum from wrapped Knoll/Prom keys
		0x9C	error	Knoll returned an invalid response to a command
		0x9D	error	Bootloader failed in Knoll Send Command function
		0x9E	error	No Knoll device found by verifying MAC
		0x9F	error	The maximum allowable error post code
		0xA0	error	Bootloader successfully entered C Main
		0xA1	error	Master initialized C2P / slave waited for master to init C2P
		0xA2	error	HMAC key successfully derived
		0xA3	error	Master got Boot Mode and sent boot mode to all slaves
		0xA4	error	SpiRom successfully initialized
		0xA5	error	BIOS Directory successfully read from SPI to SRAM
		0xA6	error	Early unlock check
		0xA7	error	Inline Aes key successfully derived
		0xA8	error	Inline-AES key programming is done
		0xA9	error	Inline-AES key wrapper derivation is done
		0xAA	error	Bootloader successfully loaded HW IP configuration values
		0xAB	error	Bootloader successfully programmed MBAT table
		0xAC	error	Bootloader successfully loaded SMU FW
0xAD	error	Progress code is available		
0xAE	error	User mode test Uapp completed successfully		
0xAF	error	Bootloader loaded Agesa0 from SpiRom		
0xB0	error	AGESA phase has completed		
0xB1	error	RunPostDramTrainingTests() completed successfully		
0xB2	error	SMU FW Successfully loaded to SMU Secure DRAM		
0xB3	error	Sent all required boot time messages to SMU		
0xB4	error	Validated and ran Security Gasket binary		
0xB5	error	UMC Keys generated and programmed		
0xB6	error	Inline AES key wrapper stored in DRAM		
0xB7	error	Completed FW Validation step		
0xB8	error	Completed FW Validation step		
0xB9	error	BIOS copy from SPI to DRAM complete		
0xBA	error	Completed FW Validation step		

(continued on the next page)

Hardware Information

2

This chapter lists the hardware setup procedures that you have to perform when installing or removing system components.

2.1 Chassis cover

2.1.1 Removing the rear cover

1. Remove the two (2) screws (one on each side of the cover) with a Phillips screwdriver.
2. Loosen the thumbscrew on the rear panel to release the cover from the chassis.
3. Firmly hold the cover and slide it towards the rear panel about half an inch until it is disengaged from the chassis.
4. Lift the cover from the chassis.

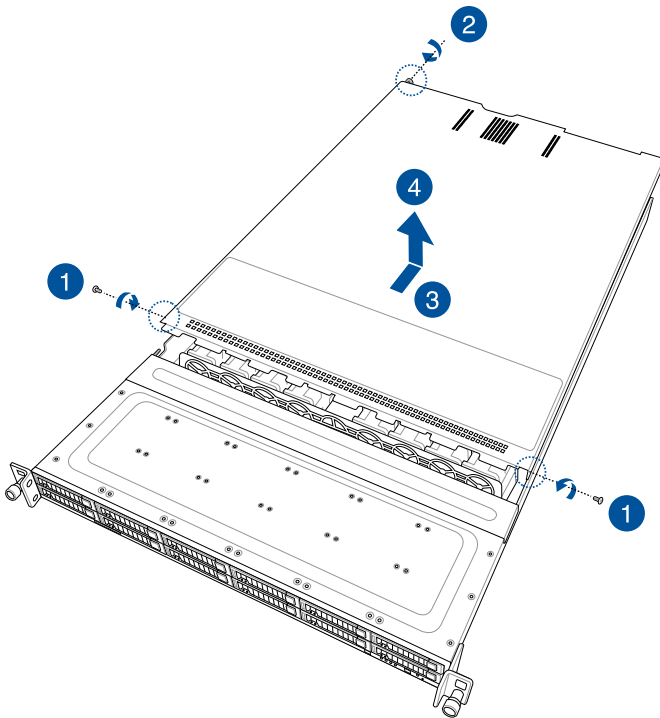

2.1.2 Removing the backplane cover

1. Remove the two (2) screws (one on each side of the cover) with a Phillips screwdriver.
2. Hold both ends of the cover (A) and lift from the chassis (B).

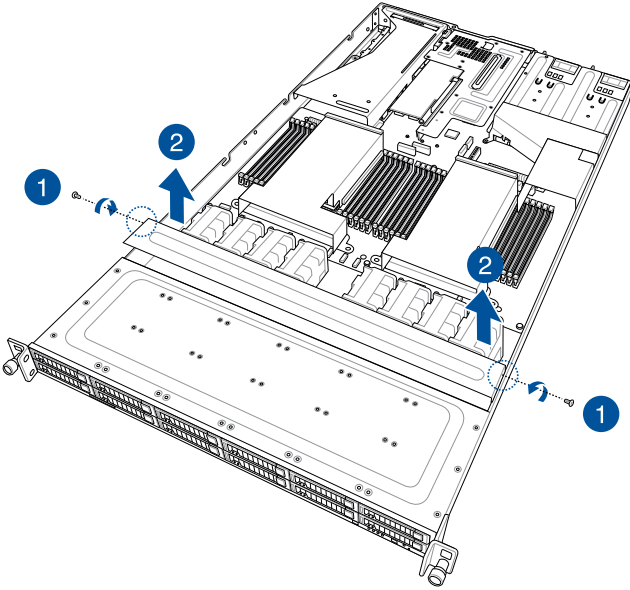

2.2 Air duct(s)

2.2.1 Removing the air duct(s)

Gently lift the two air ducts vertically out of the chassis.

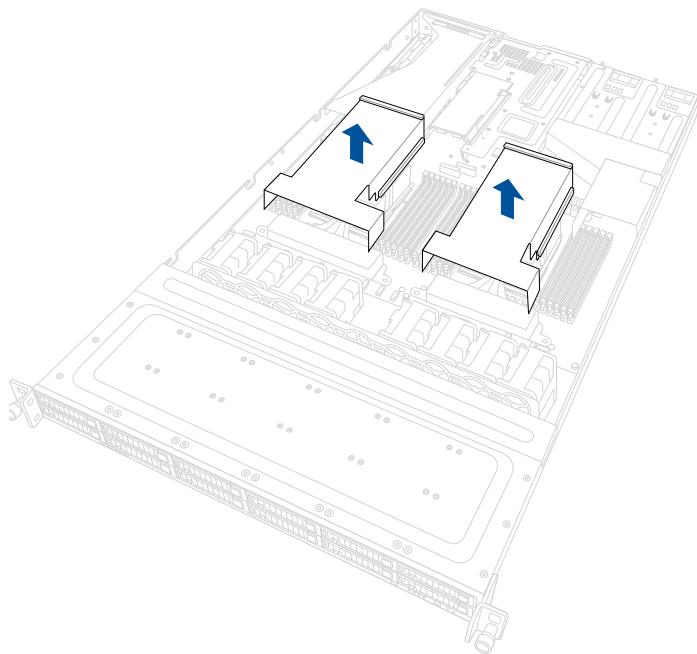

2.2.2 Installing the air duct(s)

Align the two air ducts along the edges of the DIMM slots, and then place the air ducts in the chassis

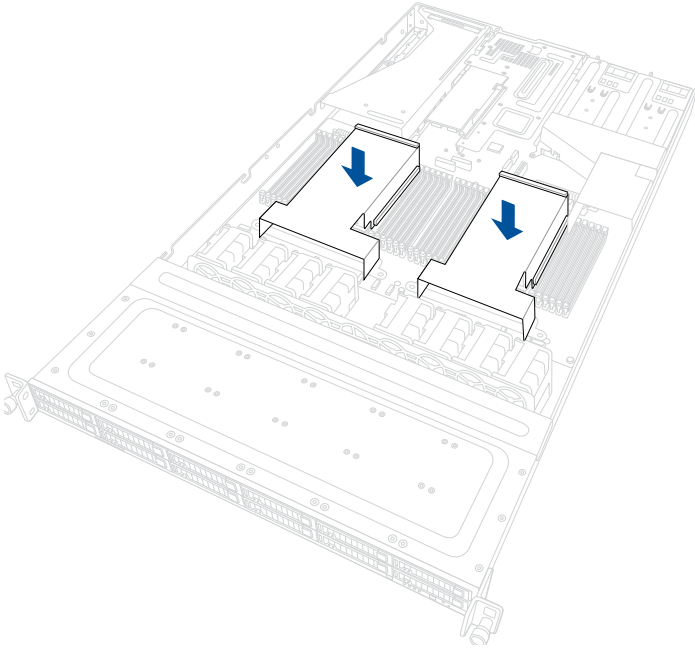

2.3 Central Processing Unit (CPU)

The motherboard comes with two surface mount SP5 sockets designed for AMD EPYC™ 9004 series processors.



- Upon purchase of the motherboard, make sure that the PnP caps are on the sockets and the socket contacts are not bent. Contact your retailer immediately if the PnP caps are missing, or if you see any damage to the PnP caps/socket contacts/motherboard components. ASUS will shoulder the cost of repair only if the damage is shipment/transit-related.
 - Keep the caps after installing the motherboard. ASUS will process Return Merchandise Authorization (RMA) requests only if the motherboard comes with the caps on the sockets.
 - The product warranty does not cover damage to the socket contacts resulting from incorrect CPU installation/removal or misplacement/loss/incorrect removal of the PnP caps.
-

2.3.1 Installing the CPU

1. Remove the rear chassis cover. For more information, see the **Chassis cover** section.
2. Remove the air ducts. For more information, see the **Air duct(s)** section.
3. Locate the CPU sockets on the motherboard.

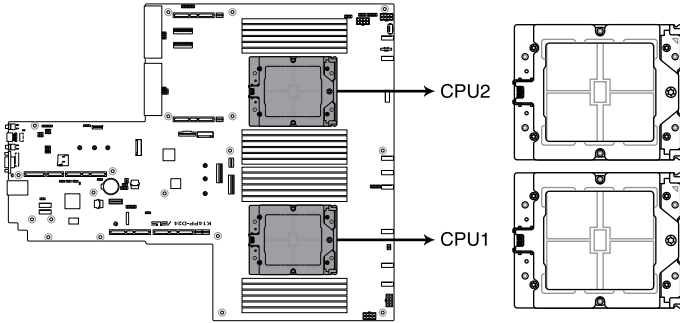

K14PP-D24 CPU Socket SP5 LGA 6096

4. Loosen the screw on the socket to open the load plate.



The load plate screws are T20 models.

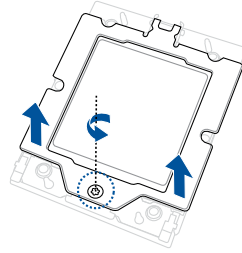

5. Lift open the rail frame.

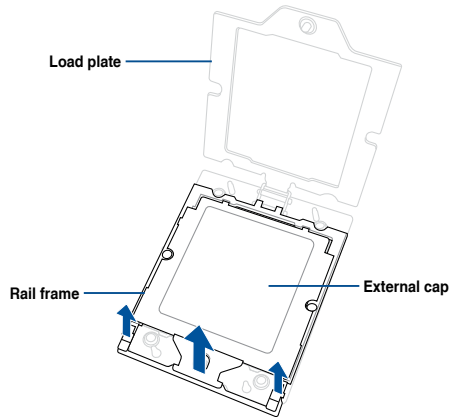

6. Slide the external cap out of the rail frame.

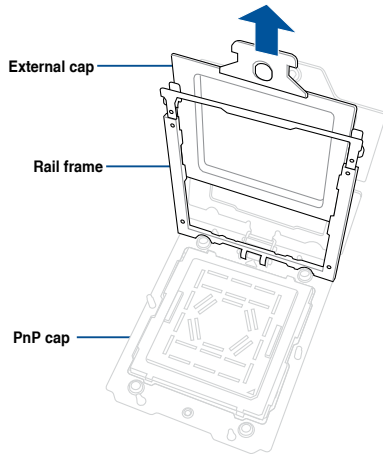

- Slide the carrier frame with CPU into the rail frame, and then remove the PnP cap.



The carrier frame with CPU fits in only one correct orientation. DO NOT force the carrier frame with CPU into the rail frame.

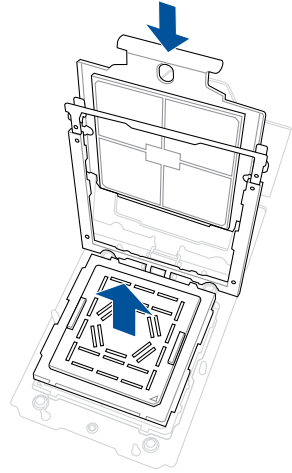

- Gently close the rail frame just enough to let it sit on top of the CPU socket.

Carrier frame with CPU

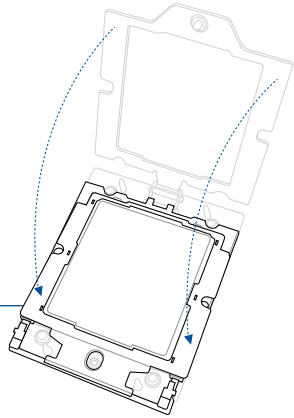

- Close the load plate just enough to let it sit on top of the CPU, then secure the load plate using the screw on the socket.



The load plate screws are T20 models. A torque value of 13.5 ± 1.0 kgf-cm (11.7 ± 0.9 lbf-in) is recommended.

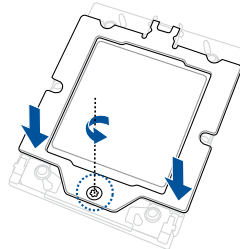

2.3.2 Installing the heatsink

1. Install the CPU. For more information, see the **Installing the CPU** section.
2. Place the heatsink on the CPU socket and make sure the heatsink screws are aligned with the CPU socket, and the screw holes on the evac is aligned with the screw holes on the chassis

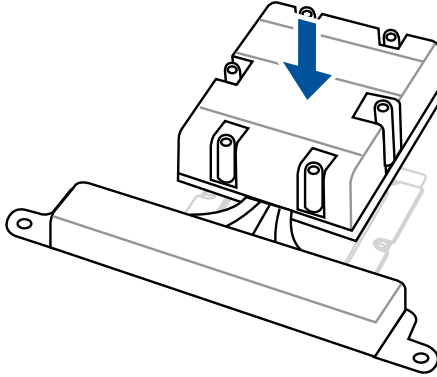

3. Partially tighten each of the six screws with a screwdriver in the order shown both in the illustration and on the heatsink just enough to attach the heatsink to the motherboard. When the six screws are attached, tighten them one by one in the same order to completely secure the heatsink.



The heatsink screws are T20 models. A torque value of 13.5 ± 1.0 kgf-cm (11.7 ± 0.9 lbf-in) is recommended.

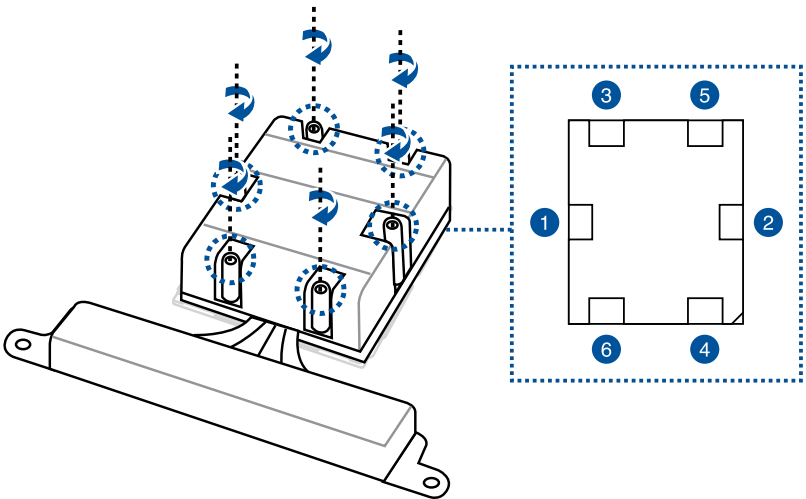

4. Tighten the remaining heatsink screws to secure the heatsink to the motherboard.

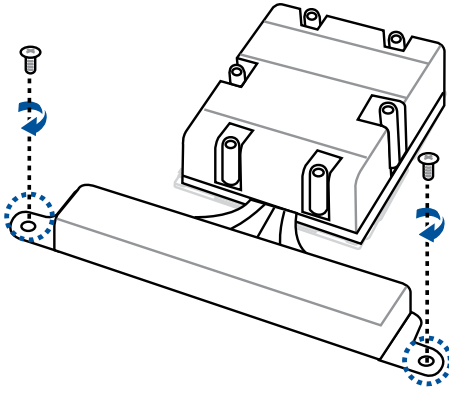

A torque value of 5.8 ± 0.3 kgf-cm (5.0 ± 0.3 lbf-in) is recommended.

2.4 System memory

2.4.1 Overview

The motherboard comes with 24 Double Data Rate 5 (DDR5) Dual Inline Memory Modules (DIMM) sockets.

The figure illustrates the location of the DDR5 DIMM sockets:

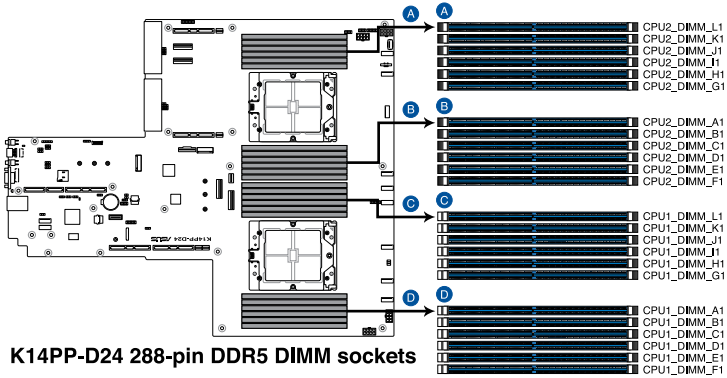

2.4.2 Memory Configurations

You may install 32GB, 64GB, and 128GB RDIMMs or 3DS RDIMMs into the DIMM sockets. If you are not sure on which slots to install the DIMMS, you can use the recommended memory configuration in this section for reference.



- Refer to ASUS Server AVL for the updated list of compatible DIMMs.
- Always install DIMMs with the same CAS latency. For optimum compatibility, it is recommended that you obtain memory modules from the same vendor.

Recommended memory configuration for 1 CPU Configuration

1 CPU Configuration (must be on CPU1)							
CPU1	DIMMs						
	1	2	4	6	8	10	12
A1	•	•	•	•	•	•	•
B1				•	•	•	•
C1			•	•	•	•	•
D1						•	•
E1					•	•	•
F1							•
G1		•	•	•	•	•	•
H1				•	•	•	•
I1			•	•	•	•	•
J1						•	•
K1					•	•	•
L1							•

Recommended memory configuration for 2 CPU Configuration

Dual CPU configuration							
CPU1	DIMMs						
	2	4	8	12	16	20	24
A1	•	•	•	•	•	•	•
B1				•	•	•	•
C1			•	•	•	•	•
D1						•	•
E1					•	•	•
F1							•
G1		•	•	•	•	•	•
H1				•	•	•	•
I1			•	•	•	•	•
J1						•	•
K1					•	•	•
L1							•
CPU2							
A1	•	•	•	•	•	•	•
B1				•	•	•	•
C1			•	•	•	•	•
D1						•	•
E1					•	•	•
F1							•
G1		•	•	•	•	•	•
H1				•	•	•	•
I1			•	•	•	•	•
J1						•	•
K1					•	•	•
L1							•

2.4.3 Installing a DIMM



Ensure to unplug the power supply before adding or removing DIMMs or other system components. Failure to do so may cause severe damage to both the motherboard and the components.

1. Unlock a DIMM socket by pressing the retaining clips outward.
2. Align a DIMM on the socket such that the notch on the DIMM matches the DIMM slot key on the socket.

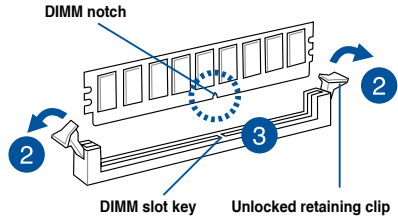

A DIMM is keyed with a notch so that it fits in only one direction. DO NOT force a DIMM into a socket in the wrong direction to avoid damaging the DIMM.

3. Hold the DIMM by both of its ends then insert the DIMM vertically into the socket. Apply force to both ends of the DIMM simultaneously until the retaining clips snaps back into place.

Ensure that the DIMM is sitting firmly on the DIMM slot.

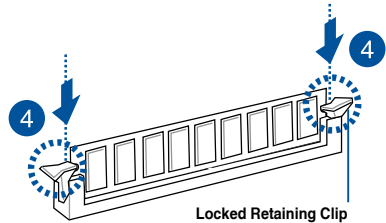

Always insert the DIMM into the socket VERTICALLY to prevent DIMM notch damage.

2.4.4 Removing a DIMM

1. Remove the chassis cover. For more information, see the section **Chassis cover**.
2. Simultaneously press the retaining clips outward to unlock the DIMM.
3. Remove the DIMM from the socket.

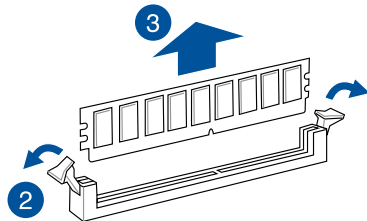

Support the DIMM lightly with your fingers when pressing the retaining clips. The DIMM might get damaged when it flips out with extra force.

2.5 (optional) Front bezel

For extra security, a front bezel (purchased separately) can be installed to prevent unauthorized physical access to the hard drives and power button.

NOTE: If the system will be installed in a cabinet, make sure that you reserve a gap of at least 45 mm between the rack post and the cabinet door.

2.5.1 Removing the front bezel

1. Push the bezel release latch on the front bezel towards the right to unlock the bezel (A) and pull the left side of the bezel slightly away from the system (B).

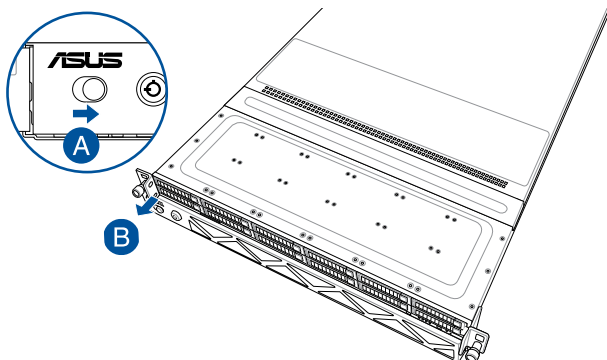

2. Slide the front bezel to the left to detach the front bezel, then remove it from the system.

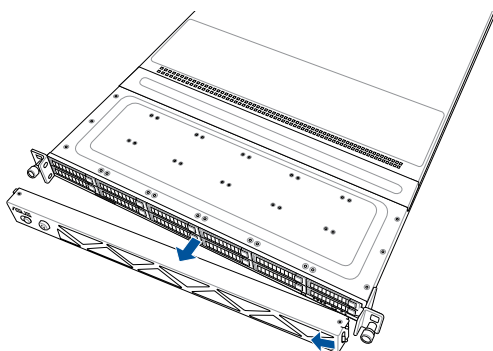

2.5.2 Installing the front bezel

1. Align the two (2) right notches on the front bezel to the notch holes on the right side of the front panel.

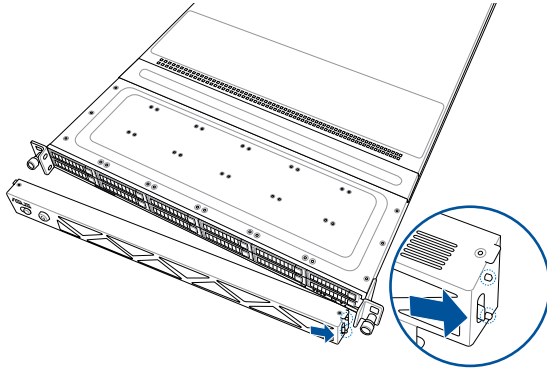

2. Push the bezel into the system until it clicks into place (A), and then slide the bezel release latch to the left to lock the bezel to the system (B).

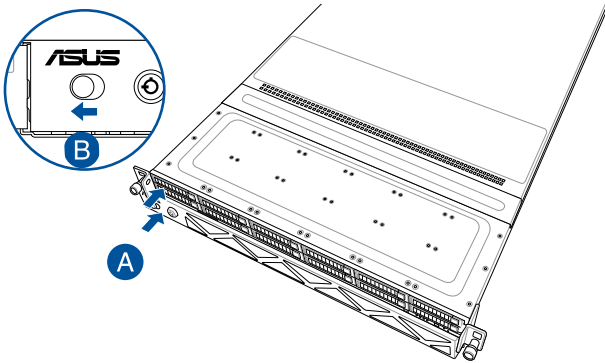

Make sure the bezel release latch is in the unlock state (pushed to the right) before attaching the bezel to the front panel.

2.6 Storage devices

The system supports up to twelve (12) 2.5" hot-swap NVMe/SATA storage devices (SAS support requires an optional HBA/RAID card). Storage devices installed on the storage device tray connect to the motherboard SATA/SAS/NVMe ports via the SATA/SAS/NVMe backplane.

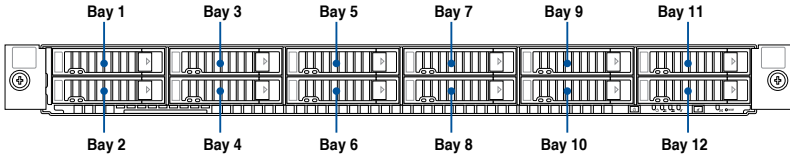

- Bays 1 to 12 support NVMe/SATA. SAS support requires an optional HBA/RAID card.
- All bays support 2.5" drives with trays.

2.6.1 Installing a 2.5" hot-swap SATA/SAS/NVMe storage device

1. Push the spring lock to the right (A), and then pull the tray lever outward (B) to release the storage device tray. The storage device tray ejects slightly after you pull out the lever.

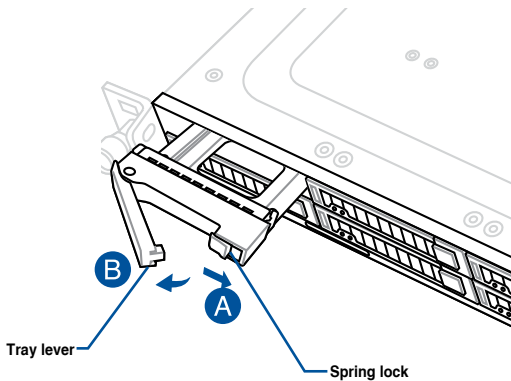

2. Firmly hold the tray lever and pull the storage device tray out of the bay.
3. Prepare the 2.5" storage device and the bundled set of screws.
4. Place the 2.5" storage device into the storage device tray, and then secure it with four screws.

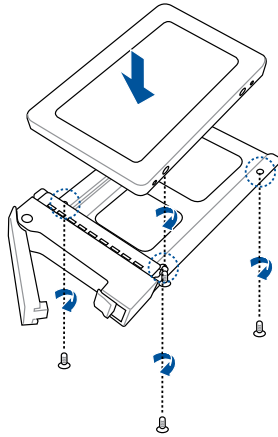

5. Push the storage device tray and HDD assembly all the way into the depth of the bay until the tray lever and spring lock click and secure the storage device tray in place.

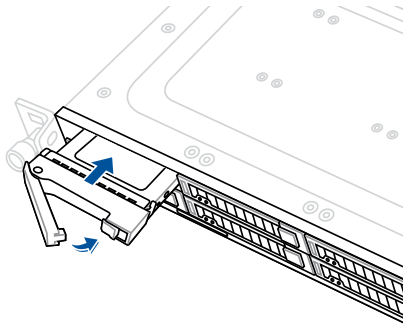

- When installed, the SATA/SAS/NVMe connector on the storage device connects to the SATA/SAS/NVMe interface on the backplane.
- The storage device tray is correctly placed when its front edge aligns with the bay edge.

6. Repeat steps 1 to 5 to install the other SATA/SAS/NVMe storage devices.

2.7 Expansion slots

The barebone server comes with two PCIe slots (A) and (B). These slots are pre-installed with a PCIe riser card bracket and a butterfly riser card bracket for installing PCIe expansion cards. You need to remove these expansion card brackets if you want to install PCIe expansion cards.

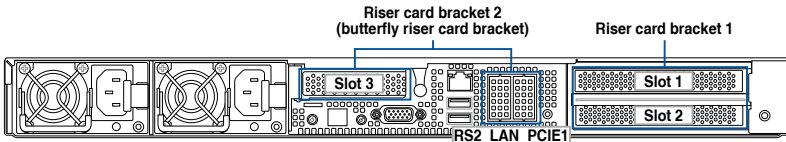
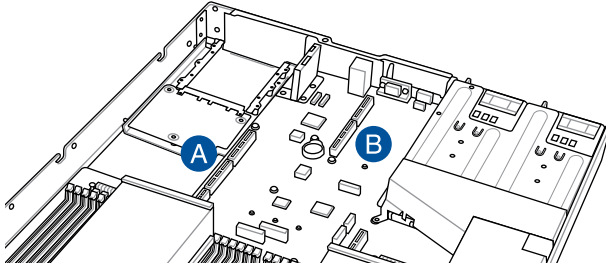

Riser card bracket 1

Riser card bracket 1 supports PCIe Gen5 slots — Slot 1 and Slot 2.

PCIe slot A	Operation mode	
	Mode 1	Mode 2
Slot 1 (RS4_PCIE1)	x16	x16
Slot 2 (RS4_PCIE2)	x16	N/A (if an OCP 3.0 module is installed)

Riser card bracket 2 (butterfly riser card bracket)

Riser card bracket 2 supports one low-profile PCIe Gen5 x16 slot (Slot 3) and one low-profile PCIe Gen5 x8 internal slot.

PCIe slot B	Operation mode
RS2_LAN_PCIE1	x16 (Gen 5)
Slot 3 (RS2_PCIE1)	x16
RS3_PCIE1 (Internal)	x8



If you will be installing expansion cards to both brackets, you will need to install the ones to riser card bracket 1 first.

2.7.1 Installing an expansion card to the PCIe riser card bracket

The PCIe riser card bracket that is pre-installed on PCIe slot A has two PCIe x16 slots. The two PCIe x16 slots provide x16 Gen5 links, with the signal for Slot 1 provided from CPU1 and the signal for Slot 2 from CPU2.

To install PCIe x16 (Gen5 x16 link) proprietary cards, such as a graphics card, to the PCIe riser card bracket:

1. Remove the butterfly riser card bracket installed on PCIe slot B. For more information, refer to **Installing an expansion card to the butterfly riser card bracket**.
2. Lift the PCIe riser card bracket out of the chassis by slipping your hands underneath the bracket where you can get a firm hold and pulling it upwards to detach it from PCIe slot A on the motherboard.

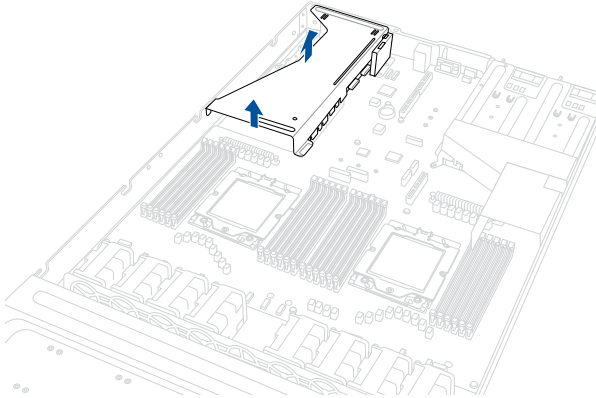

3. Prepare your expansion cards and flip the PCIe riser card bracket over.
4. Flip the metal bracket lock open (A), and then slide the two metal brackets out of the PCIe riser card bracket (B).

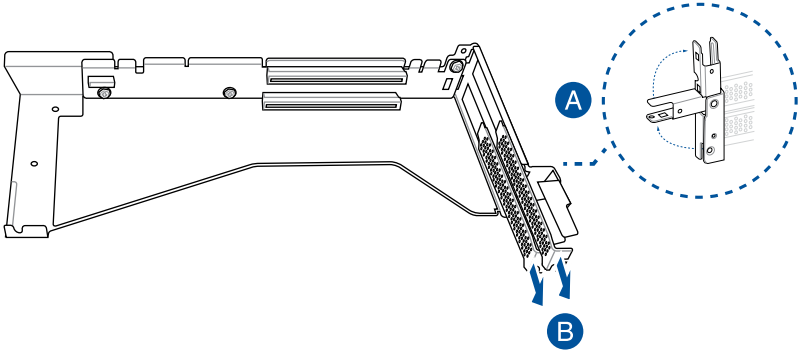

5. (optional) Install the GPU back bracket to the location shown in the illustration below using two (2) screws.



Follow this step only if you are installing a graphics card.

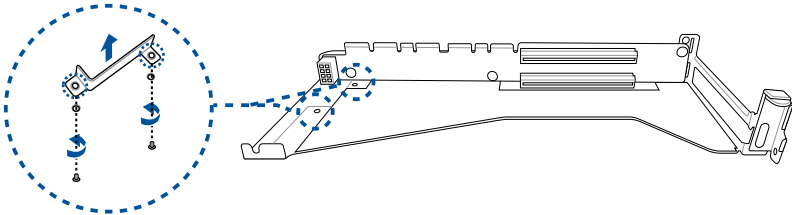

6. Install your expansion cards to the PCIe slots on the PCIe riser card bracket. The illustration below is an example of a graphics card.

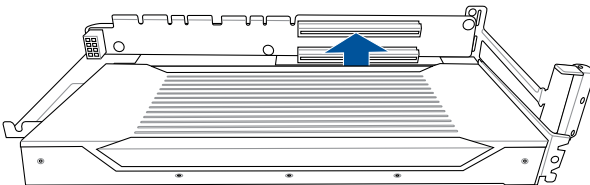

7. Once your expansion cards are installed, flip the metal bracket lock back to secure the expansion cards to the PCIe riser card bracket.

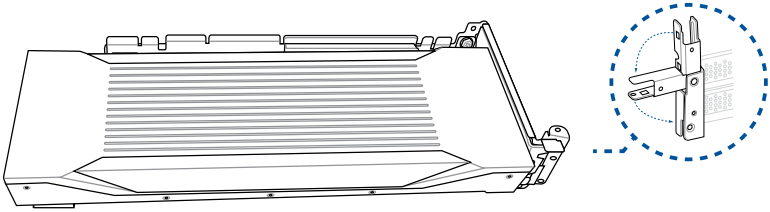

8. Align the PCIe riser card bracket to the notch holes on the chassis and PCIe slot A on the motherboard, and then push the PCIe riser card bracket down until it is seated firmly in the chassis.



Make sure that no cables are below or in the way of the PCIe riser card bracket when installing it to the chassis.

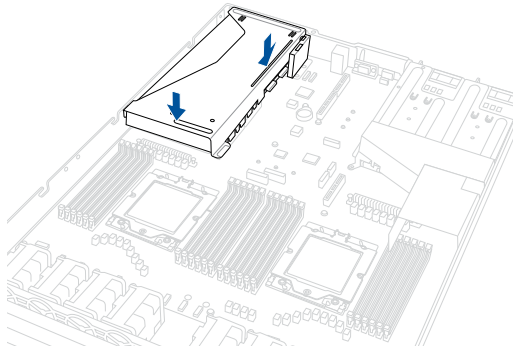

9. Replace the butterfly riser card bracket. For more information please refer to **Installing an expansion card to the butterfly riser card bracket.**

2.7.2 Installing an OCP 3.0 card

To install an OCP card to the PCIe riser card bracket:

1. (optional) Remove two (2) screws from the bottom of the chassis securing the OCP metal bracket (A) in the rear of the system, then remove the OCP metal bracket (B).

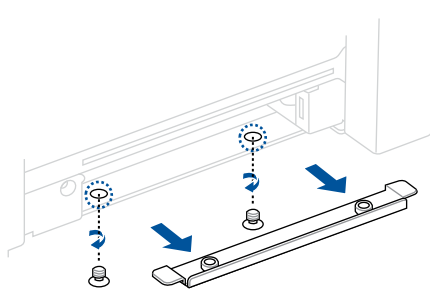

2. Insert the OCP 3.0 card into the OCP 3.0 slot from the rear of the system.
3. Make sure the OCP 3.0 card is seated securely in the OCP 3.0 slot, and then secure it using the thumbscrew.

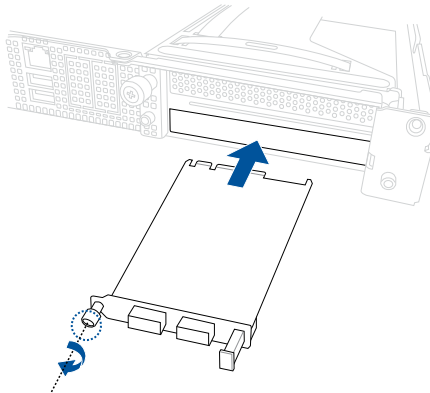

2.7.3 Installing an expansion card to the butterfly riser card bracket

The pre-installed butterfly riser card bracket on PCIe slot B supports Low Profile (LP), Half-Length (HL) PCIe x16 expansion cards.

To install a PCIe x16 (Gen5 x16 link) expansion card on the butterfly riser card bracket:

1. Lift the butterfly riser out of the chassis by firmly holding it by the tab and pulling it upwards to detach it from the PCIe x16 slot on the motherboard.

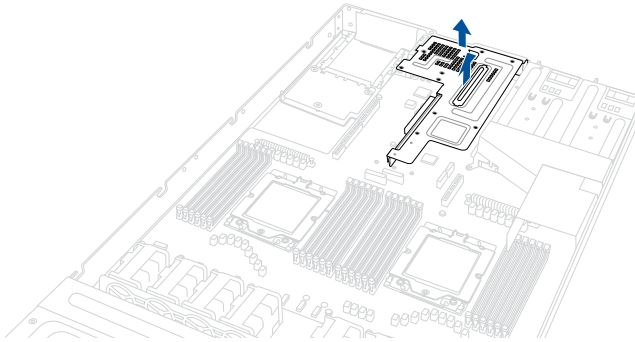

2. Flip the butterfly riser card bracket over, and then flip the metal bracket lock open (A) to remove the metal bracket (B).

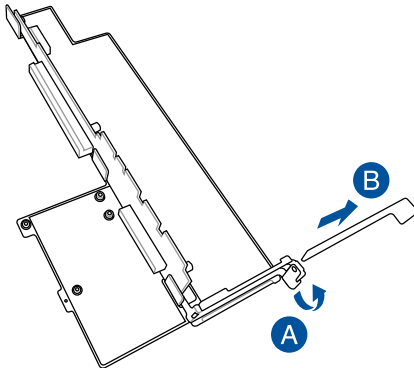

3. Install the expansion card to the **RS2_PCIE1** slot on the butterfly riser card bracket (A), and then flip the metal bracket lock back to secure the card (B).

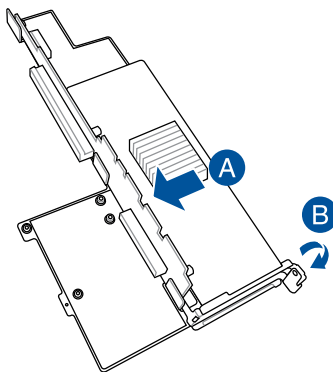

4. Align the butterfly riser card bracket to PCIe slot B on the motherboard and push down until the butterfly riser card bracket is seated securely in the chassis.

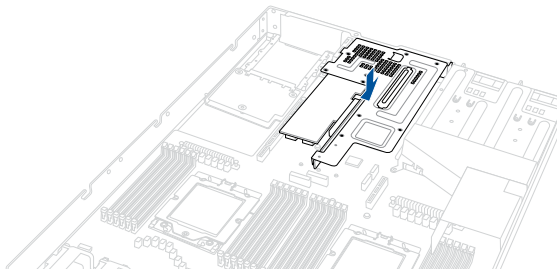

2.7.4 Installing an ethernet expansion card to the butterfly riser card bracket

The pre-installed butterfly riser card bracket can support a 4-port Intel® I350-AM4 1G LAN controller expansion card or 2-port Intel® X710-AT2 Gigabit 10G LAN controller expansion card.



Do not install a 4-port Intel® I350-AM4 1G LAN controller expansion card if you plan to install an external rear fan.

To install a 4-port Intel® I350-AM4 1G LAN controller expansion card or 2-port Intel® X710-AT2 Gigabit 10G LAN controller expansion card on the butterfly riser card bracket:

1. Follow step 1 of **Installing an expansion card to the butterfly riser card bracket** to remove the butterfly riser card bracket from the chassis.
2. Flip the butterfly riser card bracket over and insert the 4-port Intel® I350-AM4 1G LAN controller expansion card or 2-port Intel® X710-AT2 Gigabit 10G LAN controller expansion card to the **RS2_LAN_PCIE1** slot (A) on the butterfly riser card bracket, then secure it using two (2) screws (B).

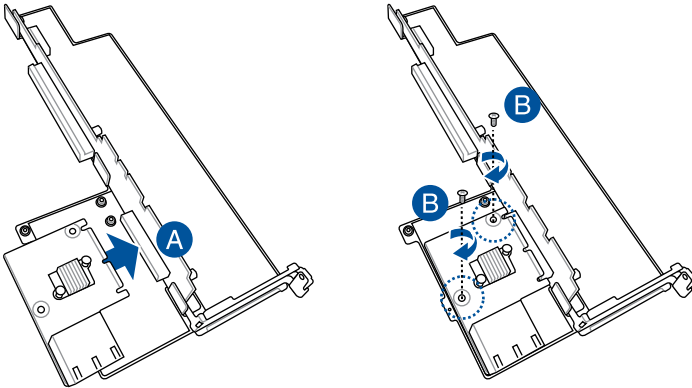

3. Follow step 4-5 of **Installing an expansion card to the butterfly riser card bracket** to install the butterfly riser card bracket to the chassis.

2.7.5 Installing an HBA/RAID card to the butterfly riser card bracket

1. Prepare the HBA/RAID card.
2. Remove the two (2) screws on the HBA/RAID card (A), and then remove the card bracket (B).

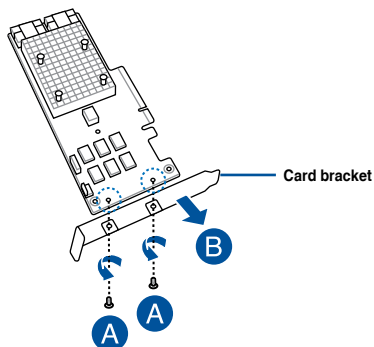

3. Follow step 1 of **Installing an expansion card to the butterfly riser card bracket**, to remove the butterfly riser card bracket from the chassis.
4. Flip the butterfly riser card bracket over and insert the HBA/RAID card into the internal **RS3_PCIE1** slot (A), and then secure it using two (2) screws (B).

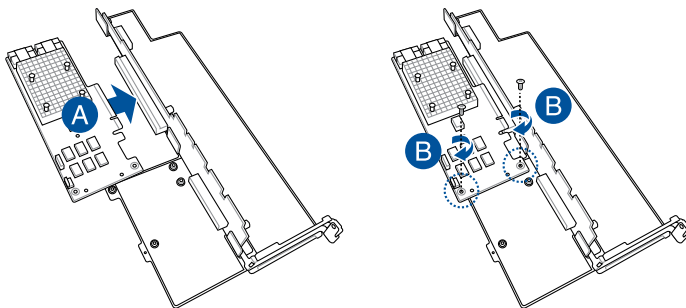

5. Follow step 4-5 of **Installing an expansion card to the butterfly riser card bracket** to install the butterfly riser card bracket to the chassis.
6. Connect the MCI0/miniSAS cables from the HBA/RAID card (A) to the NVMe/SATA/SAS backplane (B). Refer to the section **Backplane cabling** for the locations of the MCI0 connectors.

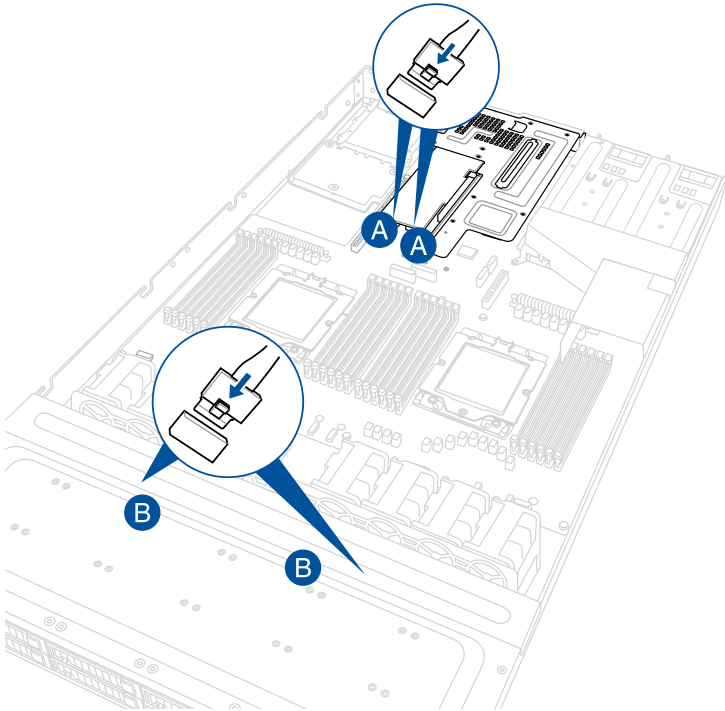

-
- The illustration above is for reference only.
 - For more information or assistance, refer to www.asus.com.
-

2.7.6 Removing the HBA/RAID card from the butterfly riser card bracket

1. Follow step 1 of **Installing an expansion card to the butterfly riser card bracket** to remove the butterfly riser card bracket from the chassis.
2. Disconnect the cables from the HBA/RAID card.

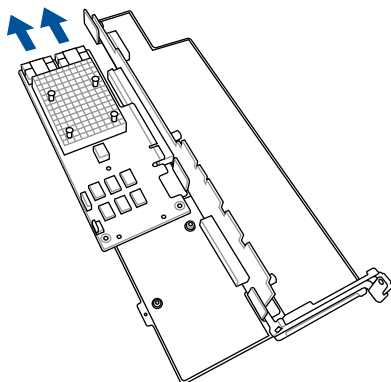

3. Remove the two (2) screws securing the card to the butterfly riser card bracket (A), and then remove the HBA/RAID card (B).

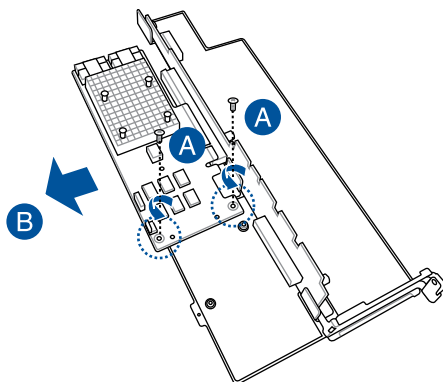

2.7.7 Installing the Cache Vault Power Module

The cache vault power module is required for selected HBA/RAID card models. You may install the cache vault power module to the butterfly riser card bracket. Please refer to the steps below to install the cache vault power module to your server system.

To install the cache vault power module:

1. Follow steps 1 and 2 of the **Installing an expansion card to the butterfly riser card bracket** section to remove the butterfly riser card bracket from the chassis.
2. Align the three screw holes on the Cache Vault Power Module clip with the three screw holes on the riser bracket, then secure the clip with the three bundled screws and hex nuts.

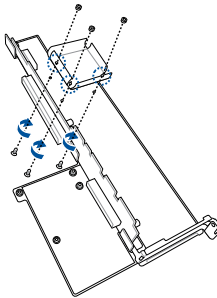

3. Align and install the Cache Vault Power Module into the Cache Vault Power Module clip.

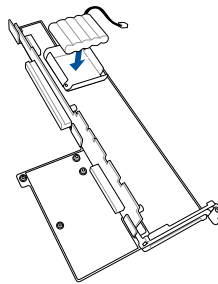

4. Connect the Cache Vault Power Module to the S-CAP connector on the HBA RAID card.
5. Install the butterfly riser card bracket back into the PCIe slot on the motherboard. Make sure that the gold fingers on the butterfly riser card bracket is firmly seated in place.

2.7.8 Installing an M.2 (NGFF) card

You may install M.2 cards (supports 2260, 2280) to the onboard M.2 (NGFF) slots on the motherboard.

1. Remove the riser card bracket. Please refer to **Installing an expansion card to the butterfly riser card bracket** for more information.
2. Locate the M.2 connectors (NGFF1 / NGFF2) on the motherboard.

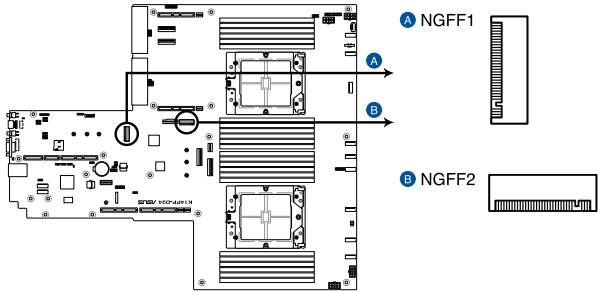

K14PP-D24 NGFF connectors

3. Select the appropriate screw hole on the motherboard for your M.2 card, then secure the bundled standoff to the motherboard.
4. Insert the M.2 card into the M.2 (NGFF) slot, and then secure the card using the bundled screw(s).

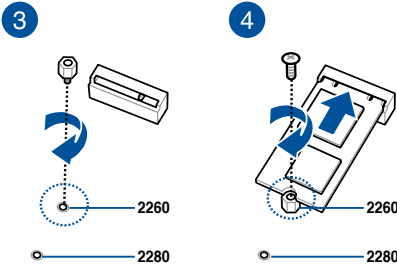

5. Repeat steps 3 and 4, if you have another M.2 card to install.

2.7.9 Configuring an expansion card

After installing an expansion card, configure it by adjusting the software settings.

1. Turn on the system and change the necessary BIOS settings, if any. Refer to the **BIOS Setup** chapter for information on BIOS setup.
2. Assign an IRQ to the card. Refer to the following tables.
3. Install the software drivers for the expansion card.

Standard Interrupt assignments

IRQ	Priority	Standard function
0	1	System Timer
1	2	Keyboard Controller
2	-	Programmable Interrupt
3*	11	Communications Port (COM2)
4*	12	Communications Port (COM1)
5*	13	--
6	14	Floppy Disk Controller
7*	15	--
8	3	System CMOS/Real Time Clock
9*	4	ACPI Mode when used
10*	5	IRQ Holder for PCI Steering
11*	6	IRQ Holder for PCI Steering
12*	7	PS/2 Compatible Mouse Port
13	8	Numeric Data Processor
14*	9	Primary IDE Channel
15*	10	Secondary IDE Channel

* These IRQs are usually available for ISA or PCI devices.

2.8 Cable connections



- The bundled system cables are pre-connected before shipment. You do not need to disconnect these cables unless you are going to remove pre-installed components to install additional devices.
- Refer to Chapter 4 for detailed information on the connectors.

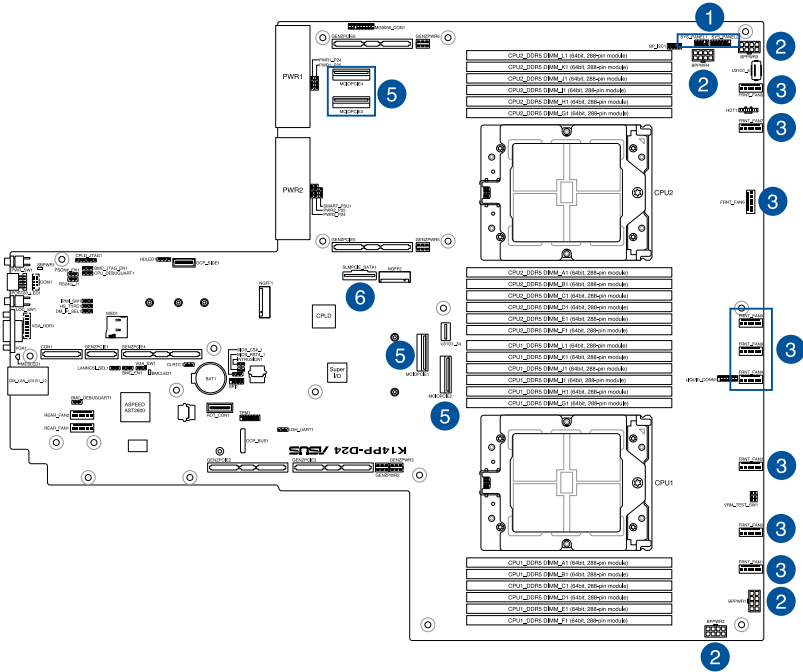

Pre-connected system cables

1. Panel connector (connected to front I/O board)
2. 8-pin BPPWR1-4 power connectors (connected to backplane)
3. System fan connectors
4. MCIOPCIE1-2 MCIO PCIe connectors (connected to backplane, supported by CPU1)
5. MCIOPCIE3-4 MCIO PCIe connectors (connected to backplane, supported by CPU2)
6. SLIMPCIE_SATA1 SlimSAS connector (connected to backplane)

2.9 Backplane cabling

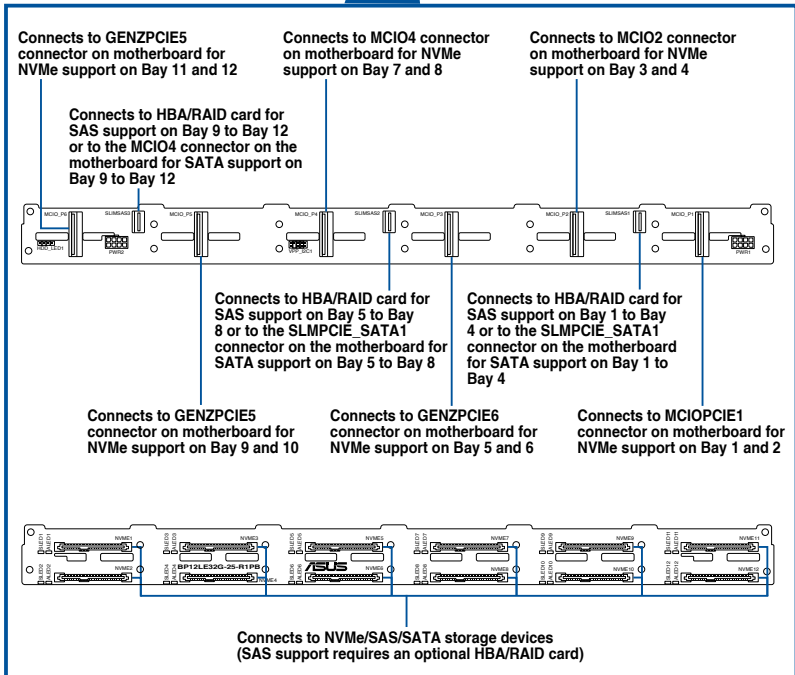
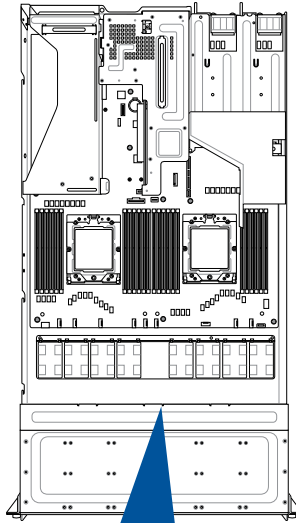

2.10 Storage device configuration and cabling

This section illustrates some storage configurations that are recommended for your server system. Before you start installing or removing the storage device cables, ensure that you have installed the correct storage devices into the supported bays.



Refer to **Storage Devices** for details on how to install storage devices.

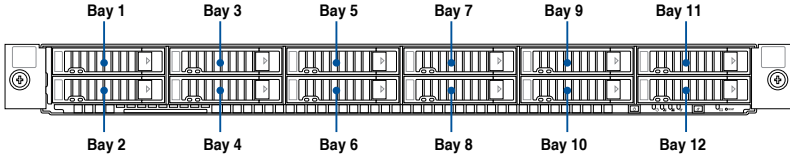

- Bays 1 to 12 support NVMe/SATA/SAS. SAS support requires an optional HBA/RAID card.
 - All bays support 2.5" drives with trays.
-

2.10.1 12 x SATA/NVMe storage device configuration and cabling



The illustrations in this section are for reference only and may vary depending on model.

1. Install the storage devices into the supported bays.



Refer to **Storage Devices** for details on how to install storage devices.

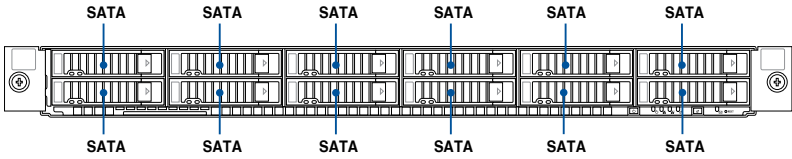

2. Remove the rear and backplane covers. For more information, refer to **Removing the rear cover** and **Removing the backplane cover**.
3. Locate the backplane (A), and then cut the cable tie(s) (B).
4. Connect the SlimSAS cables to the motherboard and the backplane.

Bays	Backplane connector	Cable	Connect to
1-4	SLIMSAS1	SlimSAS to SlimSAS	SLIMPCIE_SATA1 on motherboard
5-8	SLIMSAS2	SlimSAS to SlimSAS	SLIMPCIE_SATA1 on motherboard
9-12	SLIMSAS3	SlimSAS to SlimSAS	MCIOPCIE4 on motherboard

5. Tie the cables with cable tie(s) (A), then reinstall the backplane cover to the chassis (B).

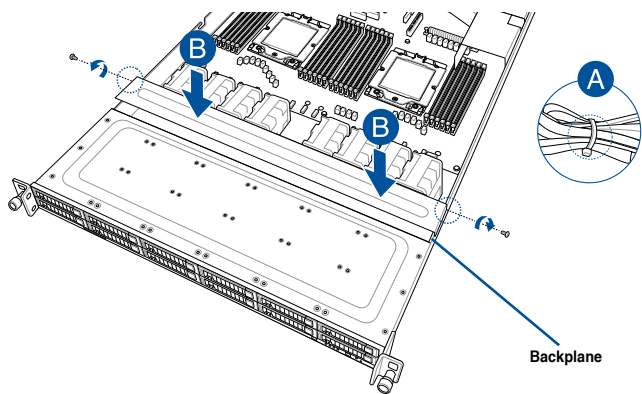

2.10.2 4 x NVMe storage device configuration and cabling



- The illustrations in this section are for reference only and may vary between models.
- You may still support either SATA for bays 1 to 12 or SAS for bays 1 to 8 with this configuration, for more information please refer to the following sections:
 - SATA support for bays 1 to 12: **12 x SATA storage device configuration and cabling**
 - SAS support for bays 1 to 8 and SATA support for bays 9 to 12: **8 x SAS and 4 x SATA storage device configuration and cabling**

Backplane connector	Cable	Connect to
MCIO_P1	MCIO to MCIO	MCIOPCIE1 on motherboard
MCIO_P2	MCIO to MCIO	MCIOPCIE2 on motherboard

1. Install the storage devices into the supported bays.



Refer to section **Storage Devices** for details on how to install storage devices.

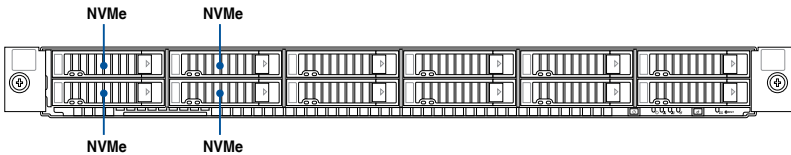

2. Remove the rear and backplane covers. For more information, refer to **Removing the rear cover** and **Removing the backplane cover**.

3. Locate the backplane (A), and then cut the cable tie(s) (B).

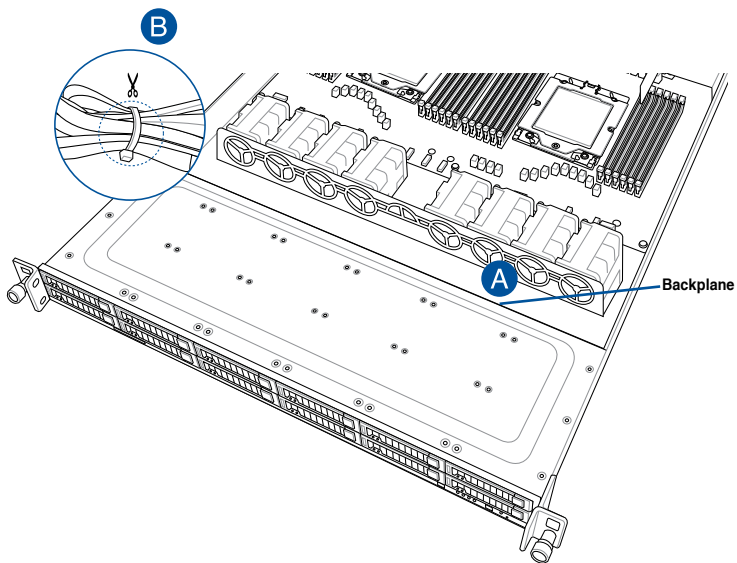

4. Connect the slimline PCIe cables to the motherboard and the backplane.

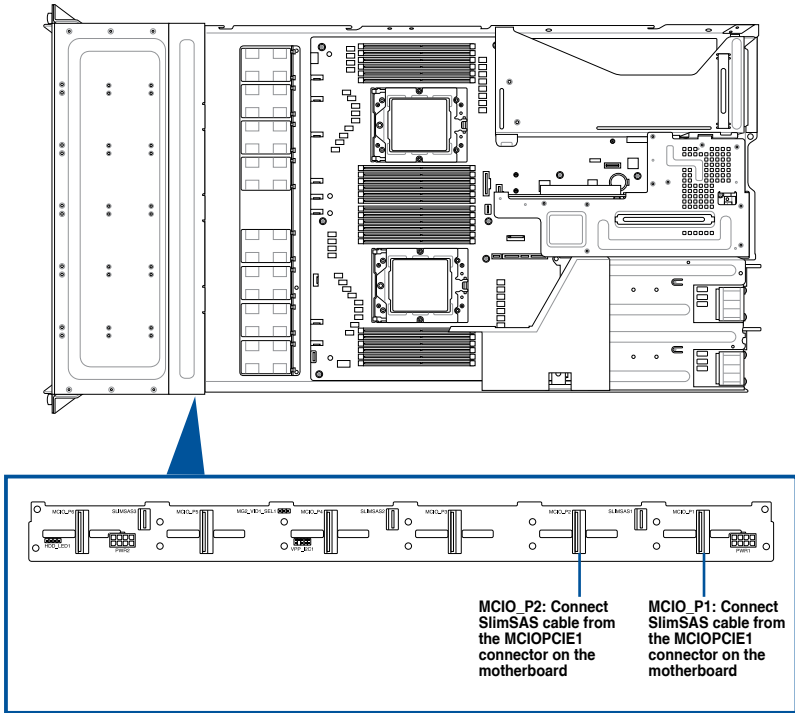

5. Tie the cables with cable tie(s) (A), then reinstall the backplane cover to the chassis (B).

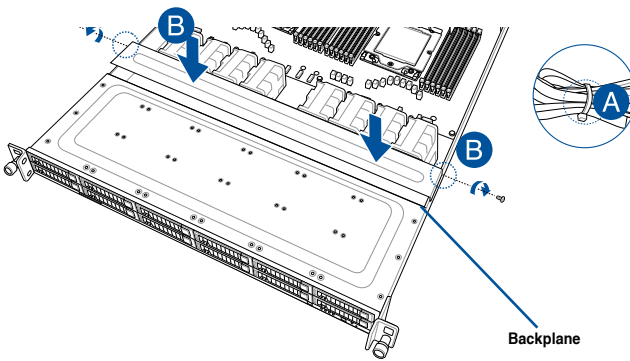

2.10.3 8 x NVMe storage device configuration and cabling



- The illustrations in this section are for reference only and may vary between models.
- You may still support either SATA for bays 1 to 12 or SAS for bays 1 to 8 with this configuration, for more information please refer to the following sections:
 - SATA support for bays 1 to 12: **12 x SATA storage device configuration and cabling**
 - SAS support for bays 1 to 8 and SATA support for bays 9 to 12: **8 x SAS and 4 x SATA storage device configuration and cabling**

Backplane connector	Cable	Connect to
MCIO_P1	MCIO to MCIO	MCIOPCIE1 on motherboard
MCIO_P2	MCIO to MCIO	MCIOPCIE2 on motherboard
MCIO_P3	MCIO to GENZ	GENZPCIE6 on motherboard
MCIO_P4	MCIO to GENZ	GENZPCIE6 on motherboard

1. Install the storage devices into the supported bays.



Refer to section **Storage Devices** for details on how to install storage devices.

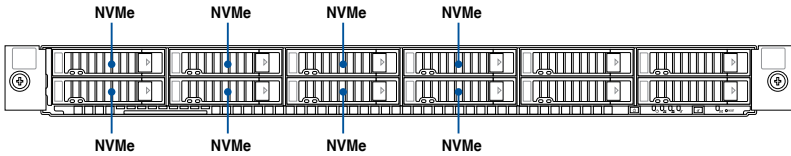

2. Remove the rear and backplane covers. For more information, refer to **Removing the rear cover** and **Removing the backplane cover**.

3. Locate the backplane (A), and then cut the cable tie(s) (B).

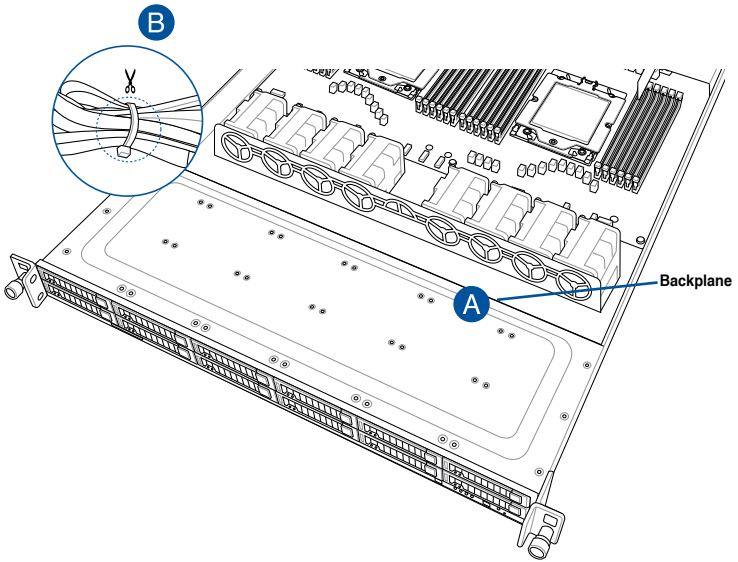

4. Connect the slimline PCIe cables to the motherboard and the backplane.

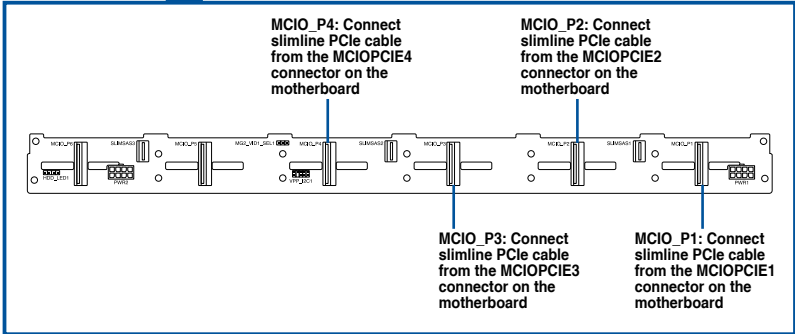
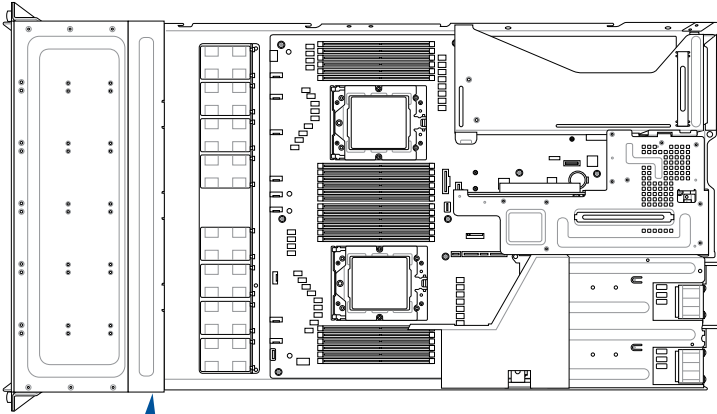

5. Tie the cables with cable tie(s) (A), then reinstall the backplane cover to the chassis (B).

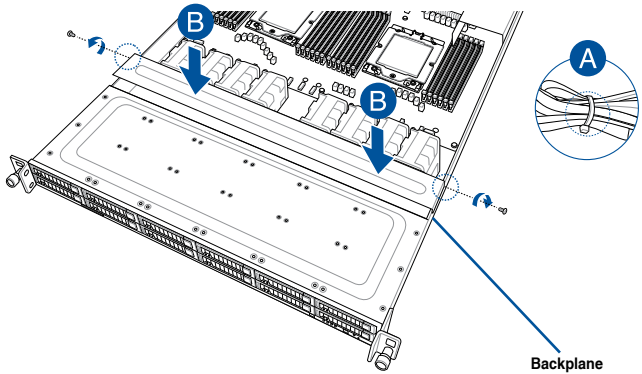

2.10.4 12 x NVMe storage device configuration and cabling



- The illustrations in this section are for reference only and may vary between models.
- You may still support one of the following configurations with this configuration, for more information please refer to the following sections:
 - SATA support for bays 1 to 12: **12 x SATA storage device configuration and cabling**
 - SAS support for bays 1 to 8 and SATA support for bays 9 to 12: **8 x SAS and 4 x SATA storage device configuration and cabling**

Backplane connector	Cable	Connect to
MCIO_P1	MCIO to MCIO	MCIOPCIE1 on motherboard
MCIO_P2	MCIO to MCIO	MCIOPCIE2 on motherboard
MCIO_P3	MCIO to GENZ	MCIOPCIE6 on motherboard
MCIO_P4	MCIO to GENZ	MCIOPCIE6 on motherboard
MCIO_P5	MCIO to GENZ	GENZPCIE5 on motherboard
MCIO_P6	MCIO to GENZ	GENZPCIE5 on motherboard

1. Install the storage devices into the supported bays.



Refer to section **Storage Devices** for details on how to install storage devices.

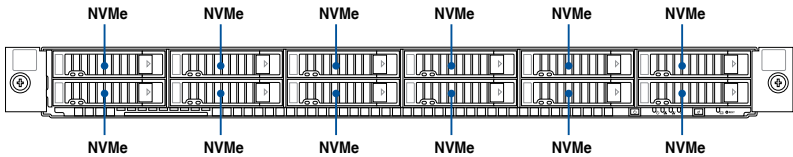

2. Remove the rear and backplane covers. For more information, refer to **Removing the rear cover** and **Removing the backplane cover**.

3. Locate the backplane (A), and then cut the cable tie(s) (B).

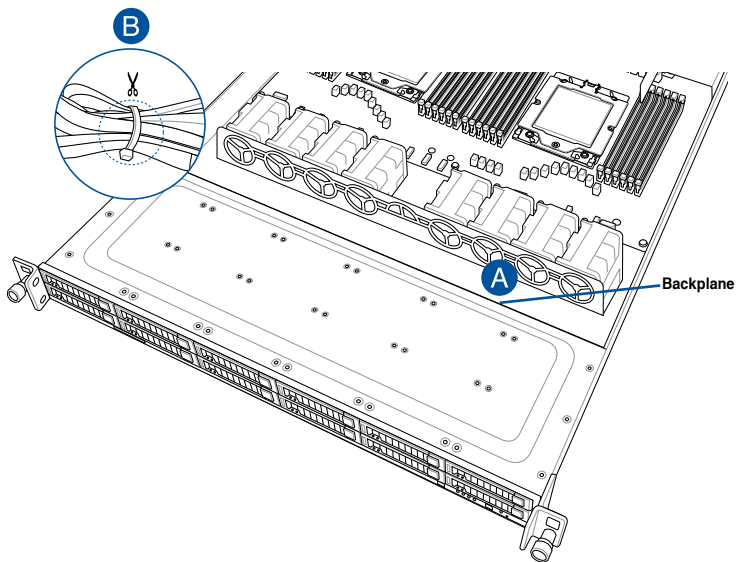

4. Connect the slimline PCIe cables to the motherboard and the backplane.

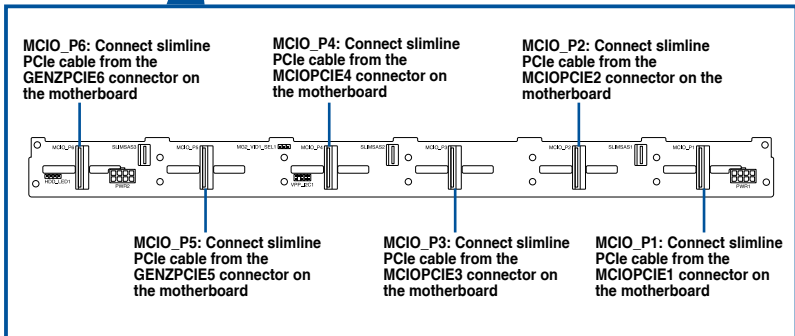
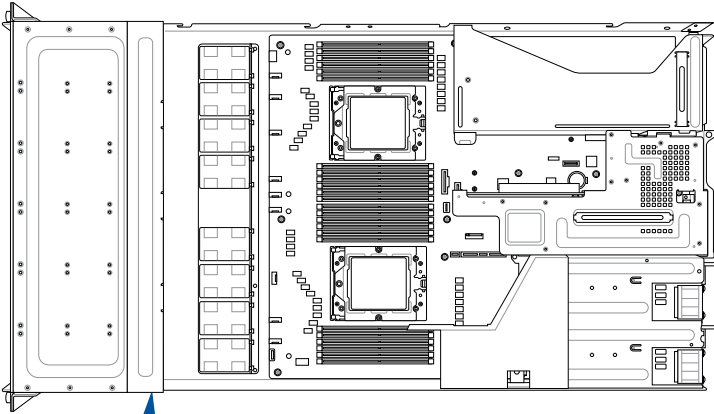

5. Tie the cables with cable tie(s) (A), then reinstall the backplane cover to the chassis (B).

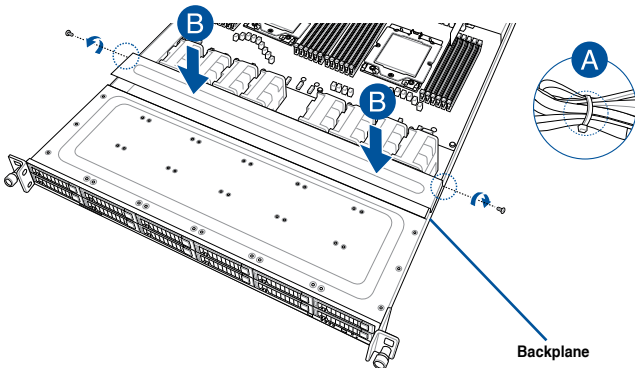

2.10.5 8 x SAS and 4 x SATA storage device configuration and cabling



- The illustrations in this section are for reference only and may vary between models.
- You may still support 4, 6 or 12 NVMe bays with this configuration, for more information please refer to the following sections:
 - 4 NVMe support: **4 x NVMe storage device configuration and cabling**
 - 8 NVMe support: **8 x NVMe storage device configuration and cabling**
 - 12 NVMe support: **12 x NVMe storage device configuration and cabling**

Backplane connector	Cable	Connect to
SLIMSAS1	SlimSAS to SlimSAS	HBA/RAID Card
SLIMSAS2	SlimSAS to SlimSAS	HBA/RAID Card
SLIMSAS3	SlimSAS to MCIO	MCIOPCIE4 on motherboard

1. Install the storage devices into the supported bays.



Refer to section **Storage Devices** for details on how to install storage devices.

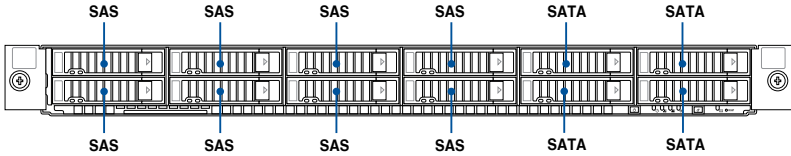

2. Install the HBA/RAID card to your system. For more information, refer to **Installing an HBA/RAID card**.

3. Locate the backplane (A), and then cut the cable tie(s) (B).

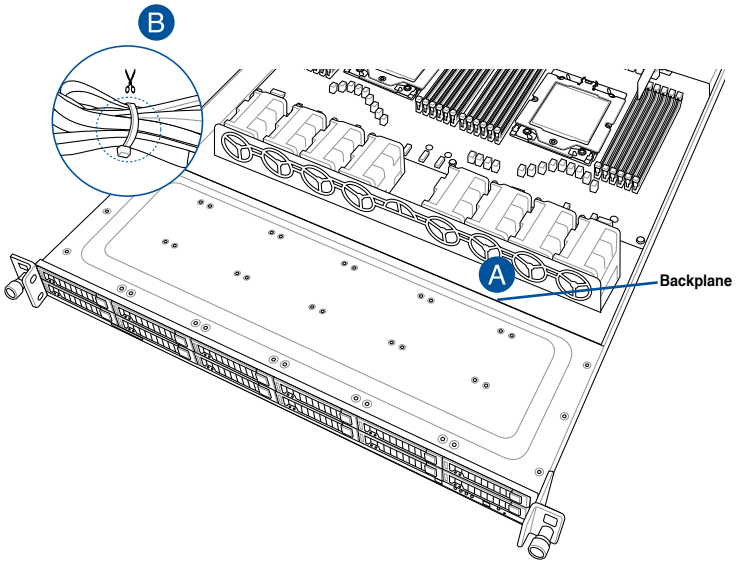

4. Connect the slimline PCIe cables to the motherboard and the backplane.

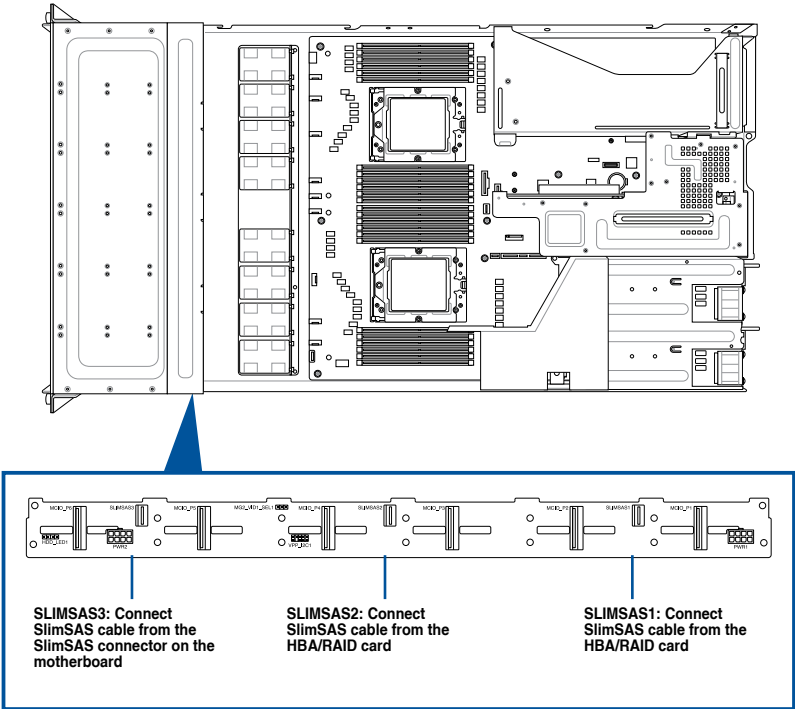

5. Tie the cables with cable tie(s) (A), then reinstall the backplane cover to the chassis (B).

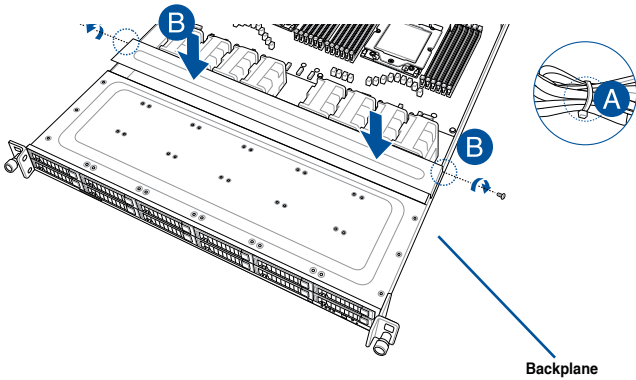

2.11 Motherboard

2.11.1 Removing the motherboard

To remove the system motherboard:

1. Disconnect the cables from the motherboard and remove any installed components on the motherboard.



Take a photo or make a note of which components are removed, which cables are disconnected, and which connectors the cables were connected to.

2. Remove the screws, then remove the motherboard.

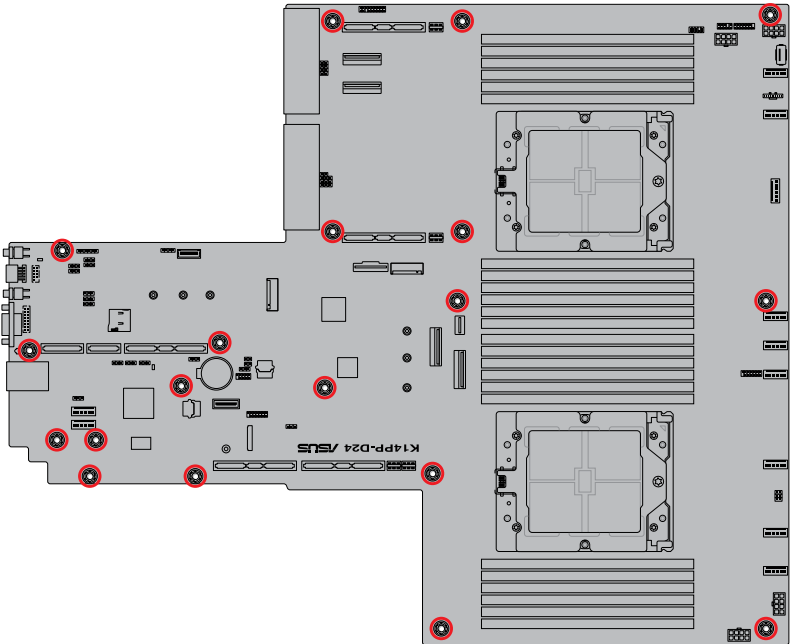

2.11.2 Installing the motherboard

To install the system motherboard:

1. Place the motherboard into the chassis and ensure the screw holes on the motherboard are aligned to the screw holes in the chassis, then secure the motherboard to the chassis using the screws removed previously.

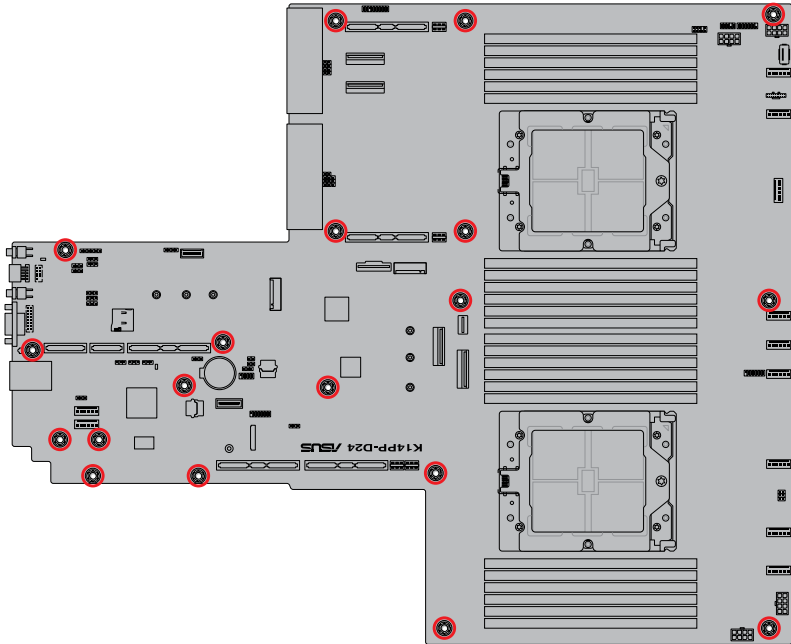

2. Reinstall removed components and reconnect the cables to the motherboard.

2.12 Removable/optional components

This section explains how to install optional components into the system and covers the following components:

1. System fans
2. Redundant power supply module
3. CMOS battery



Ensure that the system is turned off before removing any components.



You may need to remove previously installed component or factory shipped components when installing optional components.

2.12.1 System fans

To uninstall the system fans:

1. Disconnect the system fan cable from the fan connector on the motherboard.
2. Lift the fan, then set it aside.

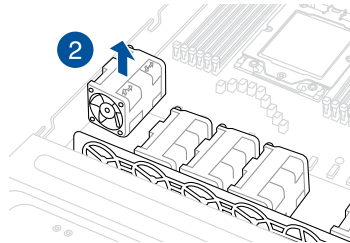
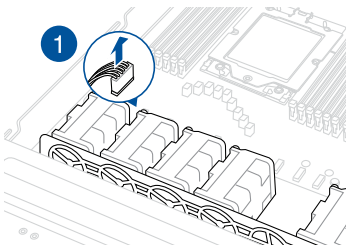

3. Repeat steps 1 to 2 to uninstall the other system fans.

To reinstall the system fans:

1. Insert the fan into the fan cage. The airflow directional arrow on the fan should point towards the system rear panel.



Ensure the notches on the fan module sit firmly into the notch holes in the chassis.

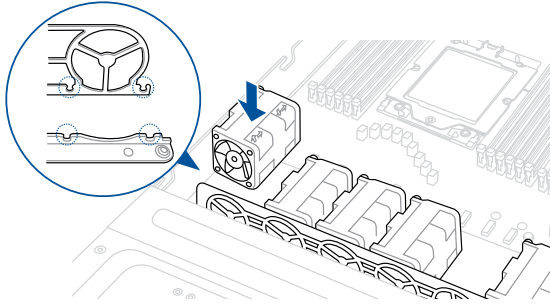

2. Connect the system fan cable to the fan connector on the motherboard.

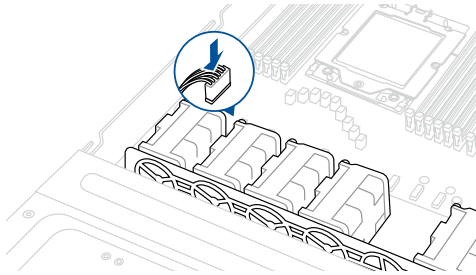

To install the external rear fan (on selected models):



- We recommend installing the external fan when you have GPU cards installed.
- The external fan is only available with selected models.

1. Use a screwdriver to pry open the slot.



Do not install the 4-port ethernet expansion card if you wish to install the external rear fan.

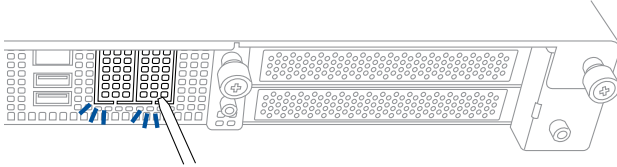

2. Prepare the rear external fan.
3. Pass the cable on the rear external fan through the open slot.

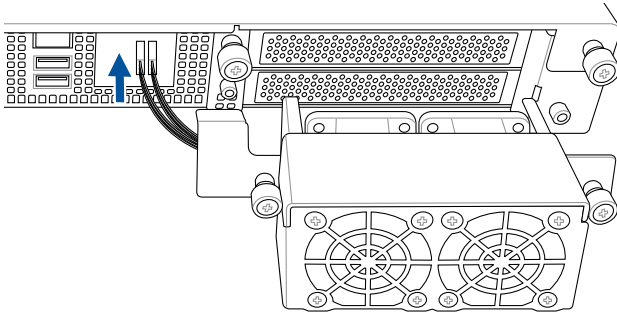

4. Connect the cables on the rear external fan to the **REAR_FAN1** and **REAR_FAN2** connectors on the motherboard.

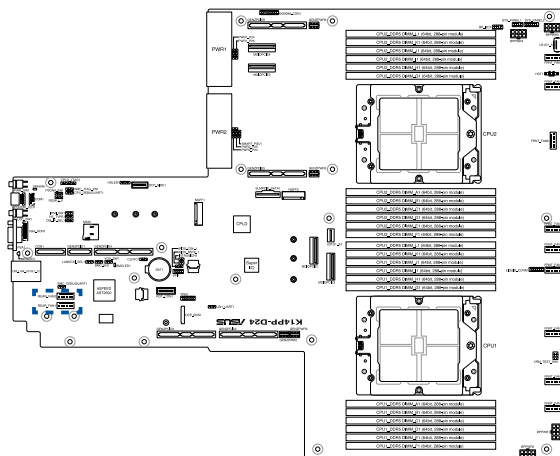

5. Align and place the rear external fan on the chassis.
6. Secure the rear external fan to the chassis with the thumbscrews.

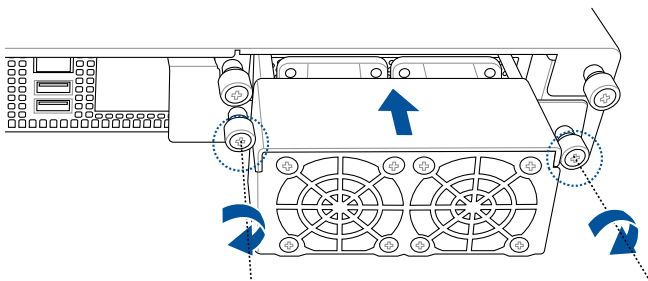

2.12.2 Redundant power supply module

To replace a failed redundant power supply module:

1. Lift up the power supply module lever.

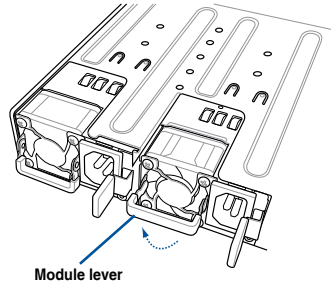

2. Hold the power supply module lever and press the PSU latch, then pull the power supply module out of the system chassis.

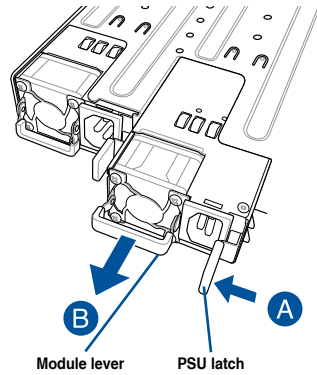

3. Prepare the replacement power supply module.
4. Insert the replacement power supply module into the chassis then push it inwards until the latch locks into place.

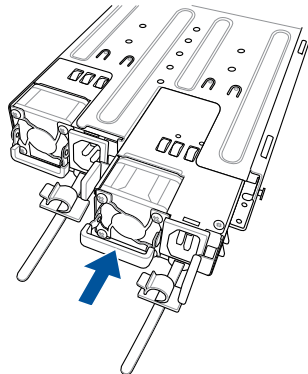

2.12.3 CMOS battery

To replace a CMOS battery:

1. Locate and remove the CMOS battery.

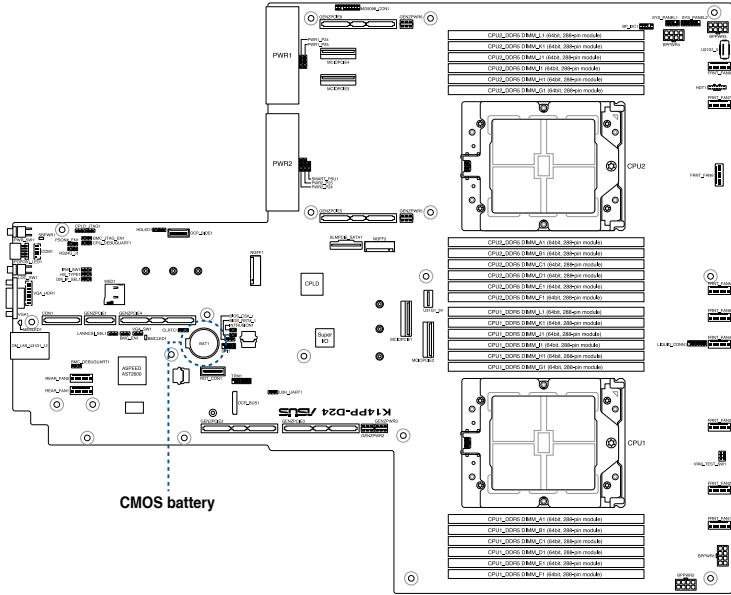

2. Place the replacement CMOS battery into the battery compartment.

2.13 Rail Kit Options

This server system supports the rail kit options listed below. For more information on rail kit installation, refer to corresponding documentation on the ASUS support site or on the official product site for this server system.



-
- We strongly recommend that at least two able-bodied persons perform the installation of the rail kit.
 - We recommend the use of an appropriate lifting tool or device, if necessary.
-

- Friction rail kit
- 1m half extension ball bearing rail kit
- 1.2m half extension ball bearing rail kit
- 1U full extension ball bearing rail kit

Motherboard Information

3

This chapter includes the motherboard layout and brief descriptions of the jumpers and internal connectors.

3.1 Motherboard layout

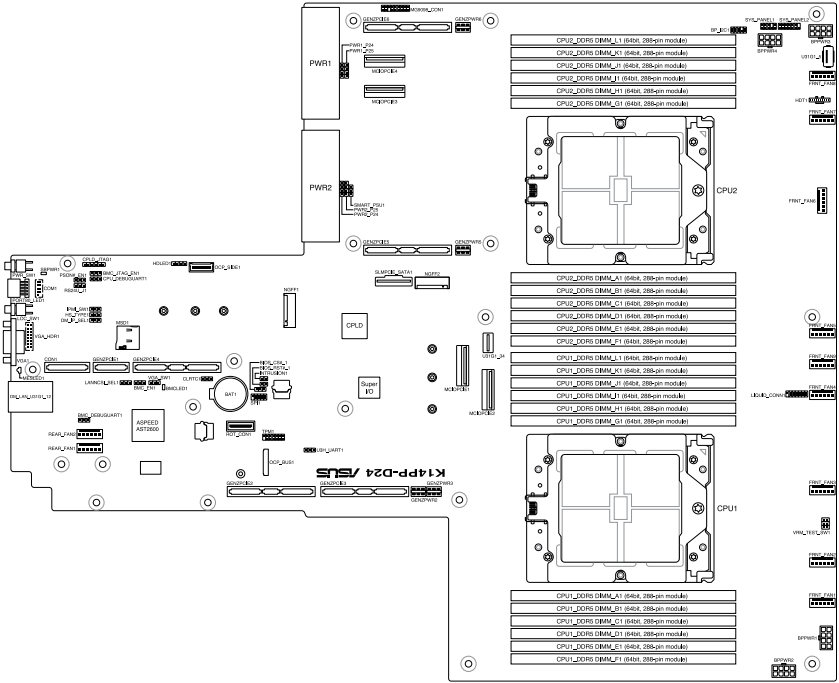

Layout contents

Central Processing Unit (CPU)	Page
LGA 6096 sockets (CPU1, CPU2)	3-5

Dual Inline Memory Module (DIMM)	Page
DDR5 sockets	3-5

Jumpers	Page
1. Clear RTC RAM (3-pin CLRRTC1)	3-6
2. VGA controller setting (3-pin VGA_SW1)	3-7
3. Baseboard Management Controller setting (3-pin BMC_EN1)	3-7
4. DMLAN setting (3-pin DM_IP_SEL1)	3-8
5. IPMI SW setting (3-pin IPMI_SW1)	3-8
6. Smart Ride Through (SmaRT) setting (3-pin SMART_PSU1)	3-9
7. LANNCSI setting (3-pin LANNCSI_SEL1)	3-9

Onboard LEDs	Page
1. Standby Power LED (SBPWR1)	3-10
2. Baseboard Management Controller LED (BMCLED1)	3-10
3. Message LED (MESLED1)	3-11

Internal connectors		Page
1.	SlimPCIe SATA connector (SLMPCIE_SATA1)	3-12
2.	MCI/O PCIe connector (MCIOPCIE1-4)	3-12
3.	USB 3.2 Gen 1 connector (U31G1_34; U31G1_5)	3-13
4.	Chassis Intrusion (2-pin INTRUSION1)	3-13
5.	Serial port connector (10-1 pin COM1)	3-14
6.	System fan connectors (6-pin FRNT_FAN1-8; REAR_FAN1-2)	3-15
7.	TPM connector (14-1 pin TPM1)	3-16
8.	M.2 (NGFF) card connector (NGFF1-2)	3-16
9.	Backplane power connector (8-pin BPPWR1-4)	3-17
10.	VGA connector (16-pin VGA_HDR1)	3-17
11.	System panel connector (10-1 pin SYS_PANEL1; 14-1 pin SYS_PANEL2)	3-18
12.	Micro SD card slot (MSD1)	3-19
13.	OCP Side connector (12-pin OCP_SIDE1)	3-19
14.	OCP Bus connector (OCP_BUS1)	3-20
15.	Hard disk activity LED connector (4-pin HDLED1)	3-20
16.	I2C connector (10-1 pin BP_I2C1)	3-21
17.	Liquid connector (12-1 pin LIQUID_CONN1)	3-21
18.	Platform Firmware Resilience (PFR) module connector (ROT_CON)	3-22

3.2 Central Processing Unit (CPU)

The motherboard comes with a surface mount SP5 socket designed for the AMD EPYC™ 9004 Series Family processors.

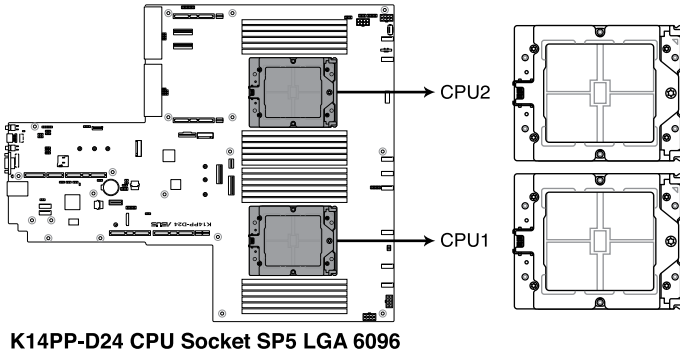

3.3 Dual Inline Memory Module (DIMM)

The motherboard comes with 24 Double Data Rate 5 (DDR5) Dual Inline Memory Modules (DIMM) sockets.

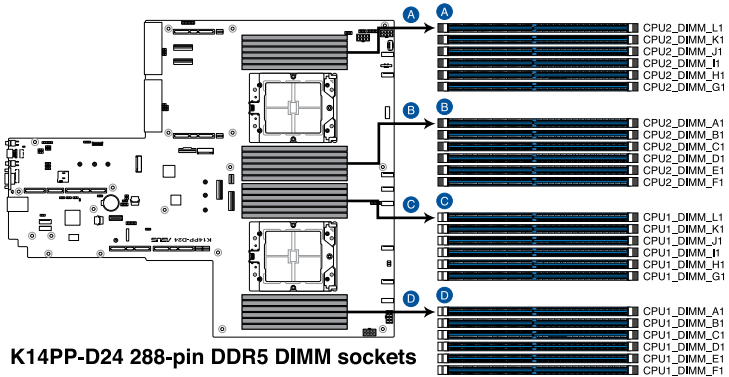

3.4 Jumpers

1. Clear RTC RAM (3-pin CLRTC1)

This jumper allows you to clear the Real Time Clock (RTC) RAM in CMOS. You can clear the CMOS memory of date, time, and system setup parameters by erasing the CMOS RTC RAM data. The onboard button cell battery powers the RAM data in CMOS, which include system setup information such as system passwords.

To erase the RTC RAM:

1. Turn OFF the computer and unplug the power cord.
2. Move the jumper cap from pins 1–2 (default) to pins 2–3. Keep the cap on pins 2–3 for about 5–10 seconds, then move the cap back to pins 1–2.
3. Plug the power cord and turn ON the computer.
4. Hold down the key during the boot process and enter BIOS setup to re-enter data.



Except when clearing the RTC RAM, never remove the cap on CLRTC jumper default position. Removing the cap will cause system boot failure!



If the steps above do not help, remove the onboard battery and move the jumper again to clear the CMOS RTC RAM data. After the CMOS clearance, reinstall the battery.

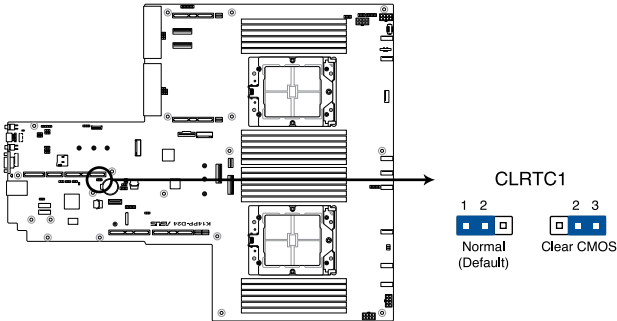

K14PP-D24 Clear RTC RAM

2. VGA controller setting (3-pin VGA_SW1)

This jumper allows you to enable or disable the onboard VGA controller. Set to pins 1–2 to activate the VGA feature.

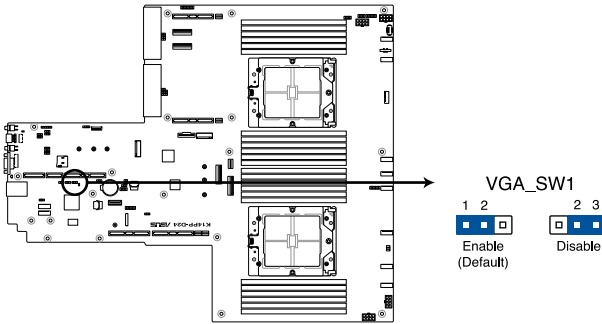

K14PP-D24 VGA setting

3. Baseboard Management Controller setting (3-pin BMC_EN1)

This jumper allows you to enable (default) or disable on-board BMC. Ensure to set this BMC jumper to enabled to avoid system fan control and hardware monitor error.

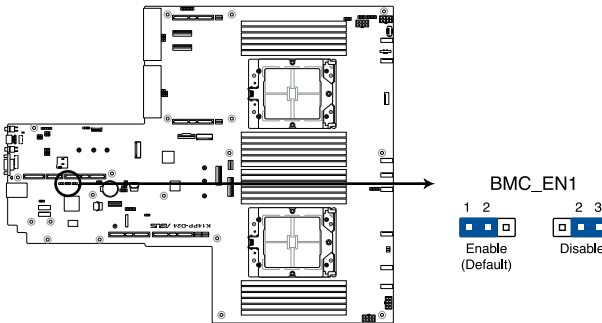

K14PP-D24 BMC setting

4. DMLAN setting (3-pin DM_IP_SEL1)

This jumper allows you to select the DMLAN setting. Set pins 2-3 to force the DMLAN IP to static mode (IP=10.10.10.10, submask=255.255.255.0).

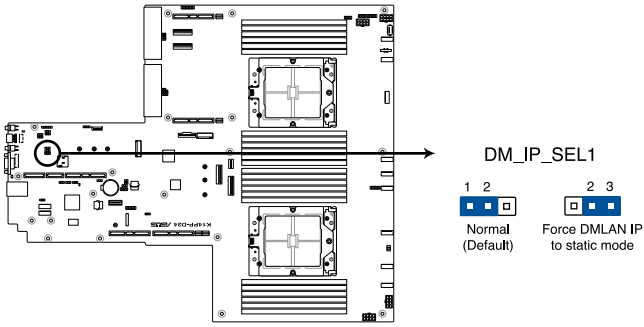

K14PP-D24 DM_IP_SEL1 setting

5. IPMI SW setting (3-pin IPMI_SW1)

This jumper allows you to select which protocol in the GPU sensor to function.

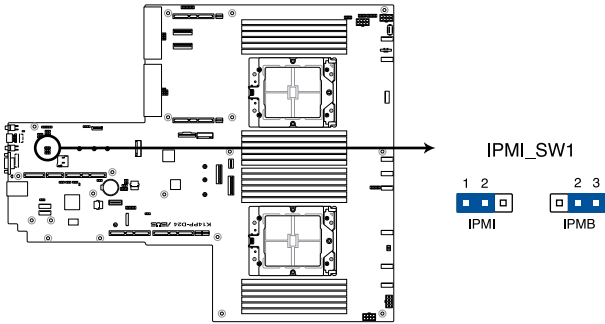

K14PP-D24 IPMI_SW1 setting

6. Smart Ride Through (SmaRT) setting (3-pin SMART_PSU1)

This jumper allows you to enable or disable the Smart Ride Through (SmaRT) function. This feature is enabled by default. Set to pins 2-3 to disable it. When enabled, SmaRT allows uninterrupted operation of the system during an AC loss event.

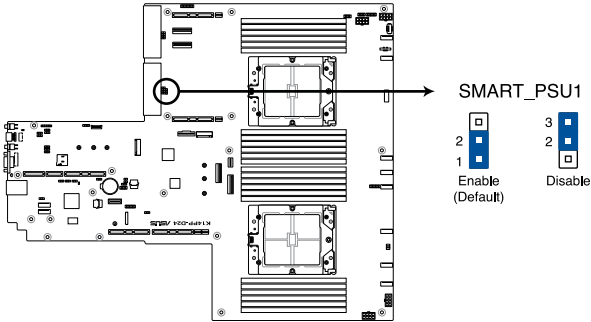

K14PP-D24 Smart Ride Through setting

7. LANNCSE1 setting (3-pin LANNCSE1_SEL1)

This jumper allows you to select which LAN NCSI to enable.

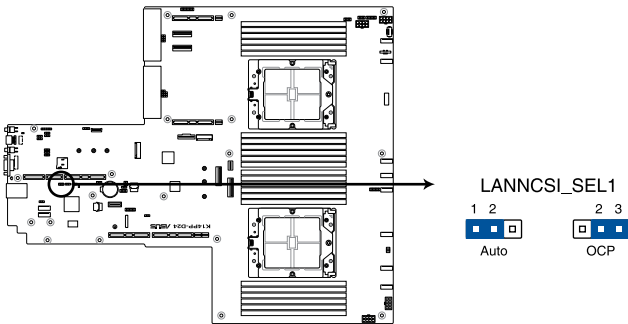

K14PP-D24 LANNCSE1_SEL1 setting

3.5 Internal LEDs

1. Standby Power LED (SBPWR1)

The motherboard comes with a standby power LED. The green LED lights up to indicate that the system is ON, in sleep mode, or in soft-off mode. This is a reminder that you should shut down the system and unplug the power cable before removing or plugging in any motherboard component. The illustration below shows the location of the onboard LED.

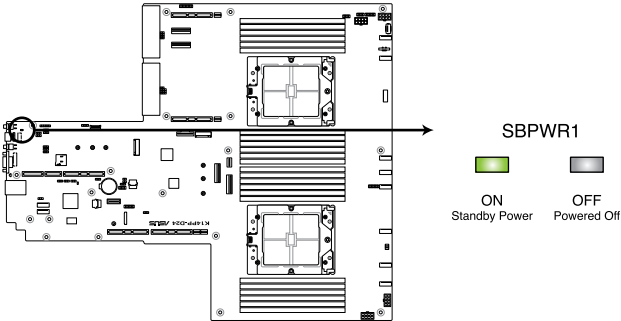

K14PP-D24 Standby Power LED

2. Baseboard Management Controller LED (BMCLED1)

The BMC LED blinks to indicate that the on-board BMC is functional.

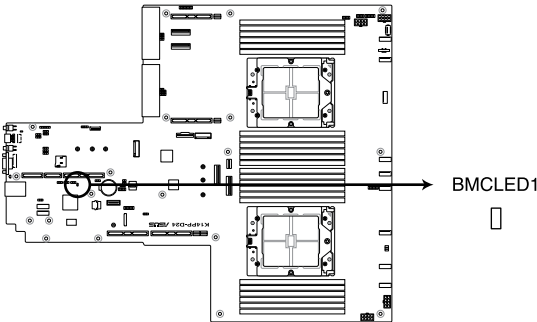

K14PP-D24 BMCLED1

3. Message LED (MESLED1)

This onboard LED lights up red when there is a BMC event log generated.

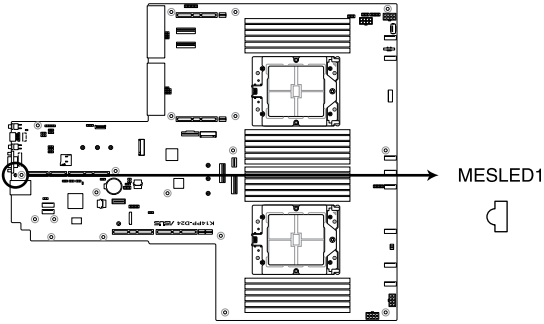

K14PP-D24 MESLED1

3.6 Internal connectors

1. SlimPCIe SATA connector (SLMPCIE_SATA1)

This motherboard comes with Slim SATA connectors, the storage technology that supports Serial ATA. Each connector supports up to eight (8) devices.

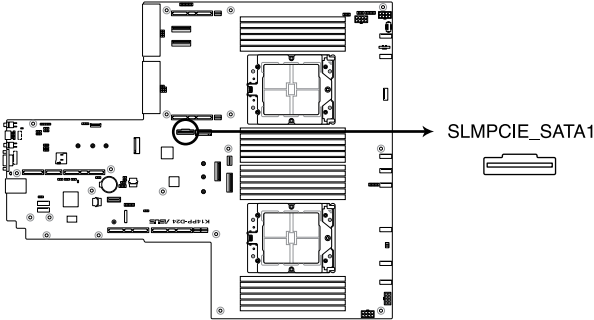

K14PP-D24 SLMPCIE_SATA connector

2. MCIOPCIe connector (MCIOPCIe1-4)

Connects the PCIe signal to the riser card or NVMe port on the backplane.

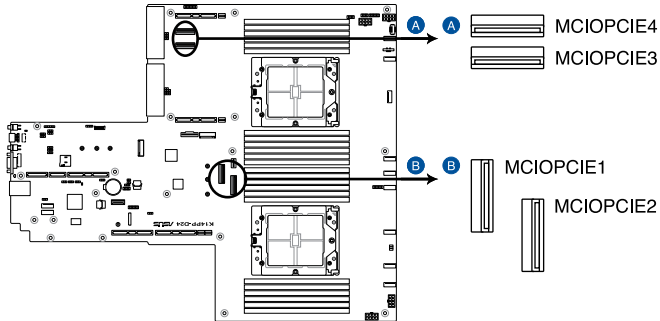

K14PP-D24 MCIOPCIe connectors

3. USB 3.2 Gen 1 connector (U31G1_34; U31G1_5)

This connector allows you to connect a USB 3.2 Gen 1 module for additional USB 3.2 Gen 1 ports on the front panel. The USB 3.2 Gen 1 connector provides data transfer speeds of up to 5 Gb/s. The Type-A connector allows you to directly connect a USB flash drive.

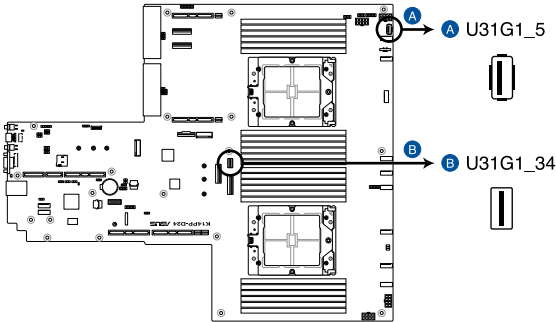

K14PP-D24 USB 3.2 Gen 1 connectors

4. Chassis Intrusion (2-pin INTRUSION1)

These leads are for the intrusion detection feature for chassis with intrusion sensor or microswitch. When you remove any chassis component, the sensor triggers and sends a high level signal to these leads to record a chassis intrusion event. The default setting is to short the CHASSIS# and the GND pin by a jumper cap to disable the function.

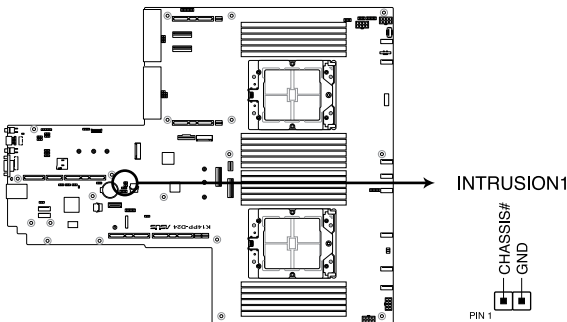

K14PP-D24 Chassis Intrusion connector

5. Serial Port connector (10-1 pin COM1)

This connector is for a serial (COM) port. Connect the serial port module cable to this connector, then install the module to a slot opening at the back of the system chassis.

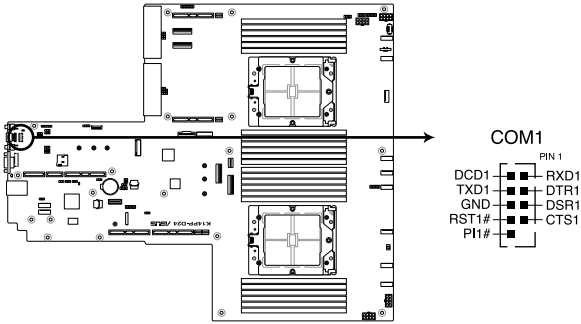

K14PP-D24 Serial port connector



The COM module is purchased separately.

6. System Fan connectors (6-pin FRNT_FAN1-8; 6-pin REAR_FAN1-2)

The 6-pin FRNT_FAN connectors are connected to the Fan board and supports 9A per pin for the +12V pins. The 6-pin REAR_FAN connectors support 3A per pin for the +12V pins. Connect the fan cables to the fan connectors on the motherboard, making sure that the black wire of each cable matches the ground pin of the connector.



DO NOT forget to connect the fan cables to the fan connectors. Insufficient air flow inside the system may damage the motherboard components. These are not jumpers! DO NOT place jumper caps on the fan connectors!

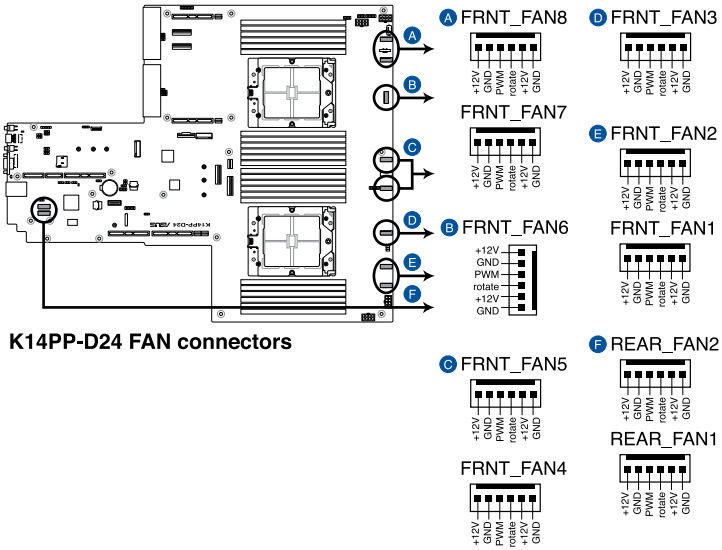

9. Backplane Power connector (8-pin BPPWR1-4)

These connectors are for the power supply plugs that connect to the backplane. The power supply plugs are designed to fit these connectors in only one orientation. Find the proper orientation and push down firmly until the connectors completely fit.

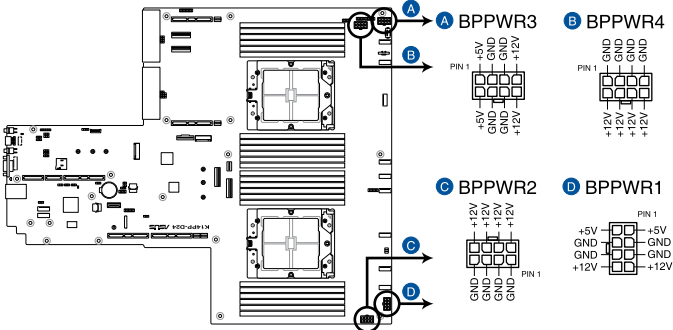

K14PP-D24 BP power connectors



DO NOT connect VGA cards to these connectors. Doing so may cause system boot errors and permanent damage to your motherboard or device.

10. VGA connector (16-pin VGA_HDR1)

This connector outputs a VGA signal to a connected display device.

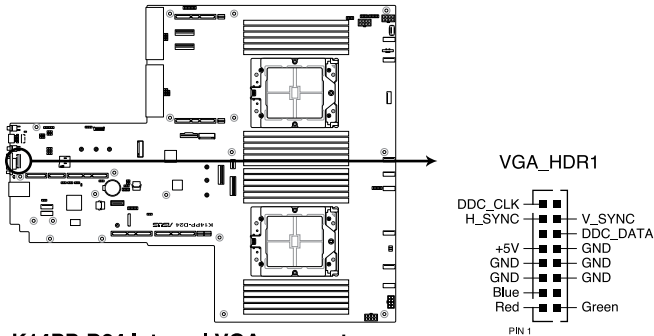

K14PP-D24 Internal VGA connector

11. System Panel connector (10-1 pin SYS_PANEL1; 14-1 pin SYS_PANEL2)

This connector supports several chassis-mounted functions.

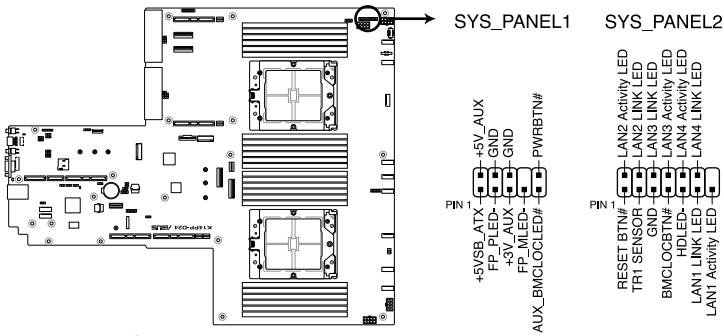

K14PP-D24 System panel connectors

- **System power LED (FP_PLED)**

This 1-pin connector is for the system power LED. Connect the chassis power LED cable to this connector. The system power LED lights up when you turn on the system power.

- **Message LED (FP_MLED)**

This 2-pin connector is for the message LED cable that connects to the front message LED. The message LED is controlled by the BMC to indicate an abnormal event occurrence.

- **Locator LED connector (AUX_BMCLOCLED)**

This connector allows you to connect the Locator LED. The Location LED helps visually locate and identify the server in error on a server rack.

- **Power Button/Soft-off Button connector (PWRBTN)**

The 3-1 pin connector allows you to connect the system power button. Press the power button to power up the system, or put the system into sleep or soft-off mode (depending on the operating system settings).

- **Reset button connector (RESETBTN)**

This connector allows you to connect the chassis-mounted reset button. Press the reset button to reboot the system.

- **TR1 Sensor connector (TR1 SENSOR)**

This connector allows detection of the environmental temperature of the front panel.

- **Locator button connector (BMCLOCBTN#)**

This connector allows you to connect the Locator button. Press the button to light up the Locator LED.

- **LAN LED connector (LAN1-4 LINK and Activity LED)**

This 2-pin connector allows you to connect the Gigabit LAN Activity LED.

- **Storage Device Activity LED connector (HDLED)**

This connector allows you to connect the Storage Device Activity LED. The Storage Device Activity LED lights up or blinks when data is read from or written to the storage device or storage device add-on card.

12. Micro SD card slot (MSD1)

Your motherboard supports SD Memory Card v2.00 (SDHC) / v3.00 (SDXC).

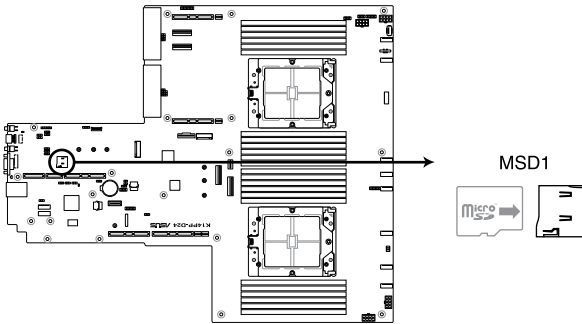

K14PP-D24 MicroSD card slot



Disconnect all power (including redundant PSUs) from the existing system before you add or remove a Memory Card, then reboot the system to access the Memory Card.

13. OCP Side connector (OCP_SIDE1)

This connector connects the OCP 3.0 Riser card sideband signals to the motherboard

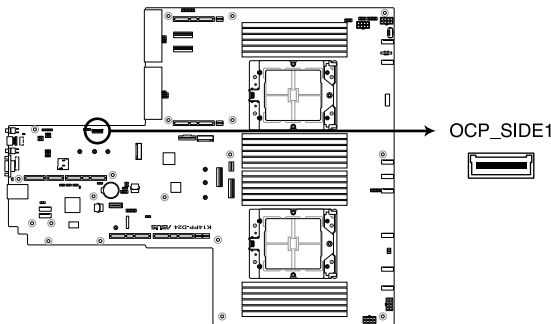

K14PP-D24 OCP_SIDE1 connector

14. OCP bus connector (OCP_BUS1)

This connector connects the OCP 3.0 Riser card NCSI signals to the motherboard

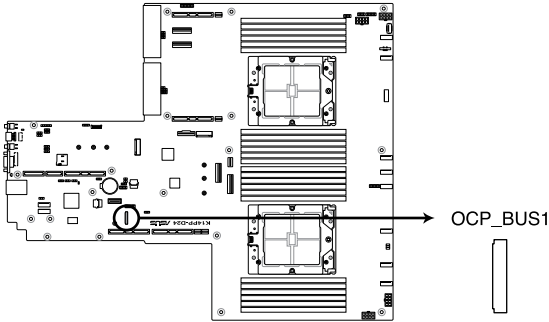

K14PP-D24 OCP_BUS1 connector

15. Hard Disk Activity LED connector (4-pin HDLED1)

This LED connector is for the storage add-on card cable connected to the SATA or SAS add-on card. The read or write activities of any device connected to the SATA or SAS add-on card causes the front panel LED to light up.

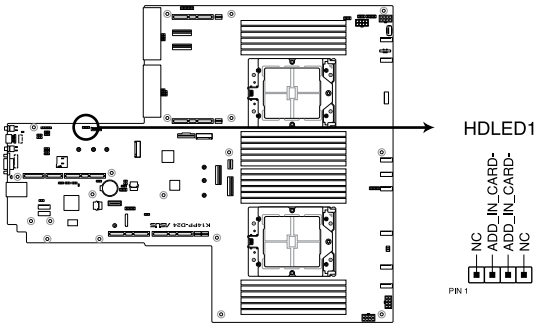

K14PP-D24 HDLED1 connector

16. I²C connector (10-1 pin BP_I2C1)

This connector is used for the AMD NVME Hot plug function and for the NVME temperature read function.

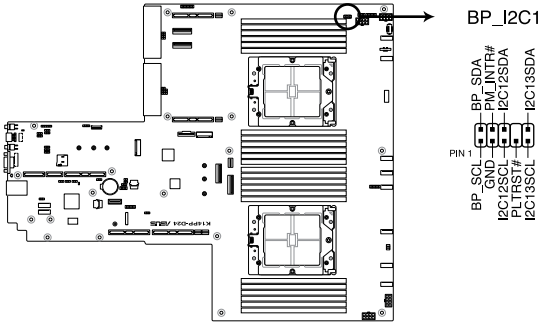

K14PP-D24 BP_I2C1 connector

17. Liquid connector (12-1 pin LIQUID_CONN1)

This connector is used for detecting the pump speed of the water cooling system.

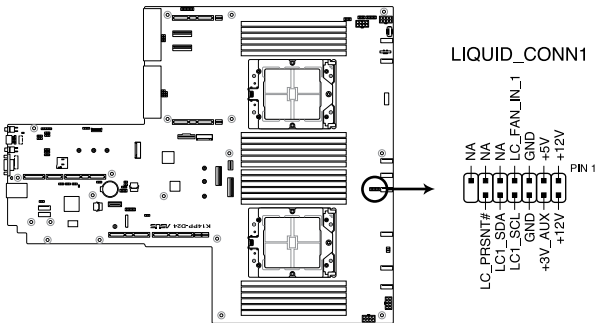

K14PP-D24 LIQUID_CONN1 connector

18. Platform Firmware Resilience (PFR) module connector (ROT_CON)

This connector allows you to connect a PFR module to enable platform firmware resilience functions.

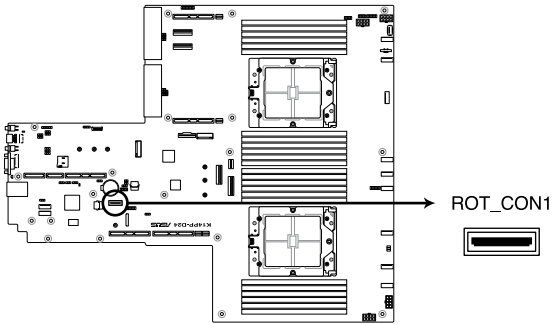

K14PP-D24 ROT_CON1 connector

BIOS Setup

4

This chapter tells how to change the system settings through the BIOS Setup menus. Detailed descriptions of the BIOS parameters are also provided.

4.1 Managing and updating your BIOS

The following utilities allow you to manage and update the motherboard Basic Input/Output System (BIOS) setup:

1. ASUS CrashFree BIOS 3

To recover the BIOS using a bootable USB flash disk drive when the BIOS file fails or gets corrupted.

2. ASUS EzFlash

Updates the BIOS using a USB flash disk.

Refer to the corresponding sections for details on these utilities.

4.1.1 ASUS CrashFree BIOS 3 utility

The ASUS CrashFree BIOS 3 is an auto recovery tool that allows you to restore the BIOS file when it fails or gets corrupted during the updating process. You can update a corrupted BIOS file using a USB flash drive that contains the updated BIOS file.



Prepare a USB flash drive containing the updated motherboard BIOS before using this utility.

Recovering the BIOS from a USB flash drive

To recover the BIOS from a USB flash drive:

1. Insert the USB flash drive with the original or updated BIOS file to one USB port on the system.
2. The utility will automatically recover the BIOS. It resets the system when the BIOS recovery finished.



DO NOT shut down or reset the system while recovering the BIOS! Doing so would cause system boot failure!



The recovered BIOS may not be the latest BIOS version for this motherboard. Visit the ASUS website at www.asus.com to download the latest BIOS file.

4.1.2 ASUS EZ Flash Utility

The ASUS EZ Flash Utility feature allows you to update the BIOS without having to use a DOS-based utility.



Before you start using this utility, download the latest BIOS from the ASUS website at www.asus.com.

To update the BIOS using EZ Flash Utility:

1. Insert the USB flash disk that contains the latest BIOS file into the USB port.
2. Enter the BIOS setup program. Go to the **Tool** menu then select **Start ASUS EzFlash**. Press <Enter>.

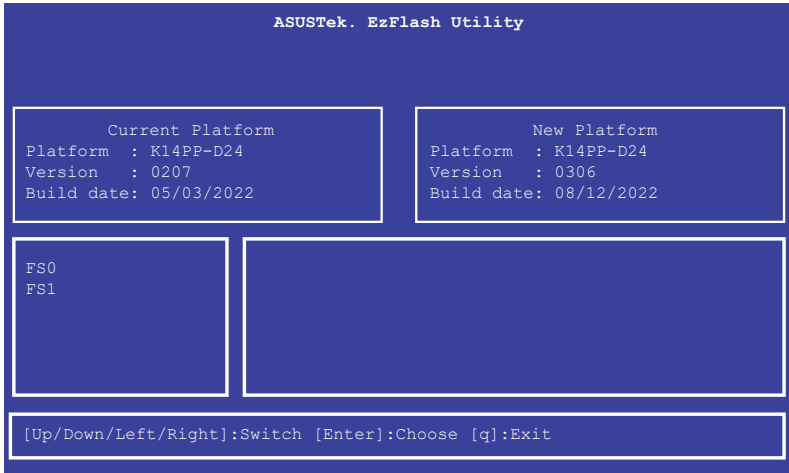

3. Press Left arrow key to switch to the **Drive** field.
4. Press the Up/Down arrow keys to find the USB flash disk that contains the latest BIOS, then press <Enter>.
5. Press Right arrow key to switch to the **Folder Info** field.
6. Press the Up/Down arrow keys to find the BIOS file, and then press <Enter> to perform the BIOS update process. Reboot the system when the update process is done.



- This function can support devices such as a USB flash disk with FAT 32/16 format and single partition only.
- DO NOT shut down or reset the system while updating the BIOS to prevent system boot failure!



Ensure to load the BIOS default settings to ensure system compatibility and stability. Press <F5> and select **Yes** to load the BIOS default settings.

4.2 BIOS setup program

This motherboard supports a programmable firmware chip that you can update using the provided utility described in section **4.1 Managing and updating your BIOS**.

Use the BIOS Setup program when you are installing a motherboard, reconfiguring your system, or prompted to “Run Setup.” This section explains how to configure your system using this utility.

Even if you are not prompted to use the Setup program, you can change the configuration of your computer in the future. For example, you can enable the security password feature or change the power management settings. This requires you to reconfigure your system using the BIOS Setup program so that the computer can recognize these changes and record them in the CMOS RAM of the firmware chip.

The firmware chip on the motherboard stores the Setup utility. When you start up the computer, the system provides you with the opportunity to run this program. Press during the Power-On Self-Test (POST) to enter the Setup utility; otherwise, POST continues with its test routines.

If you wish to enter Setup after POST, restart the system by pressing <Ctrl>+<Alt>+<Delete>, or by pressing the reset button on the system chassis. You can also restart by turning the system off and then back on. Do this last option only if the first two failed.

The Setup program is designed to make it as easy to use as possible. Being a menu-driven program, it lets you scroll through the various sub-menus and make your selections from the available options using the navigation keys.



-
- The default BIOS settings for this motherboard apply for most conditions to ensure optimum performance. If the system becomes unstable after changing any BIOS settings, load the default settings to ensure system compatibility and stability. Press <F5> and select **Yes** to load the BIOS default settings.
 - The BIOS setup screens shown in this section are for reference purposes only, and may not exactly match what you see on your screen.
 - Visit the ASUS website (www.asus.com) to download the latest BIOS file for this motherboard.
-

4.2.1 BIOS menu screen

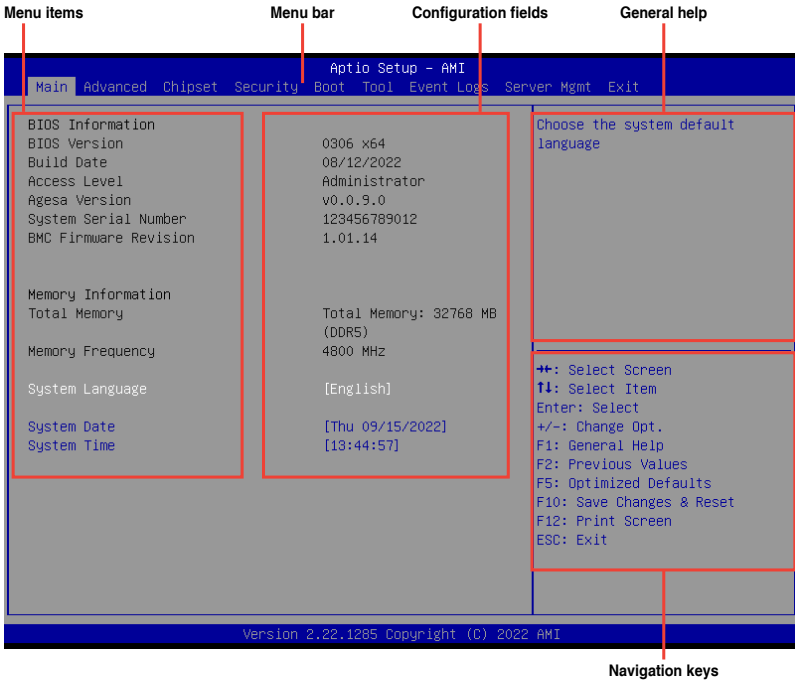

4.2.2 Menu bar

The menu bar on top of the screen has the following main items:

- Main** For changing the basic system configuration
- Performance Tuning** For changing the performance settings
- Advanced** For changing the advanced system settings
- Chipset** For changing the chipset settings
- Security** For changing the security settings
- Boot** For changing the system boot configuration
- Tool** For configuring options for special functions
- Event Logs** For changing the event log settings
- Server Mgmt** For changing the Server Mgmt settings
- Exit** For selecting the exit options

To select an item on the menu bar, press the right or left arrow key on the keyboard until the desired item is highlighted.

4.2.3 Menu items

The highlighted item on the menu bar displays the specific items for that menu. For example, selecting **Main** shows the Main menu items.

The other items (such as **Advanced**) on the menu bar have their respective menu items.

4.2.4 Submenu items

A solid triangle before each item on any menu screen means that the item has a submenu. To display the submenu, select the item then press <Enter>.

4.2.5 Navigation keys

At the bottom right corner of a menu screen are the navigation keys for the BIOS setup program. Use the navigation keys to select items in the menu and change the settings.

4.2.6 General help

At the top right corner of the menu screen is a brief description of the selected item.

4.2.7 Configuration fields

These fields show the values for the menu items. If an item is user-configurable, you can change the value of the field opposite the item. You cannot select an item that is not user-configurable.

A configurable field is enclosed in brackets, and is highlighted when selected. To change the value of a field, select it and press <Enter> to display a list of options.

4.2.8 Pop-up window

Select a menu item and press <Enter> to display a pop-up window with the configuration options for that item.

4.2.9 Scroll bar

A scroll bar appears on the right side of a menu screen when there are items that do not fit on the screen. Press the Up / Down arrow keys or <Page Up> / <Page Down> keys to display the other items on the screen.

4.3 Main menu

When you enter the BIOS Setup program, the Main menu screen appears. The Main menu provides you an overview of the basic system information, and allows you to set the system date, time, and language settings.



System Language [English]

Allows you to select the system default language.

System Date [Day xx/xx/xxxx]

Allows you to set the system date.

System Time [xx:xx:xx]

Allows you to set the system time.

4.4 Performance Tuning menu

The Performance Tuning menu items allow you to change performance related settings for different scenarios.

Item	Value	Description
Optimized Performance Setting	[Default]	Dynamically adjusts the frequency of all CPU cores based on their current utilization, delivering better performance per watt for improved system energy
Core Optimizer	[Disabled]	
Engine Boost	[Disabled]	
Overclocking	[Disabled]	
Power Balancer	[Disabled]	

Optimized Performance Setting [Default]

Allows you to select performance settings for different scenarios.

[Default] Default settings.

[By Benchmark] Optimize for different kinds of benchmarks. Select this option, then select a benchmark type from the >> list.

[By Workload] Optimize for different kinds of workloads. Select this option, then select a workload type from the >> list.



This function will reset some BIOS settings that you have changed back to their default values. Please check your BIOS settings again.



The following item appears only when **Power Balancer** is set to **[Disabled]**, or if **Optimized Performance Setting** is set to **[Default]** or **[By Benchmark]**.

Core Optimizer [Disabled]

Allows you to keep the processor operating at the turbo highest frequency for the maximum performance.

Configuration options: [Disabled] [Auto] [Manual]



The following item appears only when you set **Core Optimizer** to **[Manual]**.

CPU Max frequency [XXXX]

The default value for this option will be the maximum supported frequency of the CPU installed and may vary between different CPUs.



The following item appears only when you set **Optimized Performance Setting** to **[Default]** or **[By Benchmark]**.

Engine Boost [Disabled]

Enable this item to boost the CPU's frequency. Recommended operation at an ambient temperature of 25°C or below for optimized performance.

Configuration options: [Disabled] [Normal] [Aggressive]



Operate with an ambient temperature of 25°C or lower for optimized performance.

Overclocking [Disabled]

Enable this item to increase the CPU's clock. Please use an external PCIe storage controller for your hard drives when enabling this feature.

Configuration options: [Disabled] [Enabled]



Please note that overclocking might cause component damage or system crashes, which may reduce the lifespan of the system and the CPU. Use this tool at your own risk.



The following item appears only when you set **Core Optimizer** to **[Disabled]**, or if **Optimized Performance Setting** is set to **[Default]** or **[By Benchmark]**.

Power Balancer [Disabled]

Allows you to dynamically adjust the frequency of all CPU cores based on their current utilization, delivering better performance per watt for improved system energy efficiency.

Configuration options: [Disabled] [Enabled by ACC]



When setting **Power Balancer** to **[Enabled by ACC]**, make sure that you have the latest ASUS Control Center software installed to support Power Balancer. Please see below for recommended software versions:

- **ACC**: 1.4.3.5 version or above.



The following item appears only when you set **Power Balancer** to **[Enabled by ACC]**.

Policy [Auto]

Configuration options: [Auto] [Manual]



The following item appears only when you set **Policy** to **[Manual]**.

CPU Max frequency [XXXX]

The default value for this option will be the maximum supported frequency of the CPU installed and may vary between different CPUs.

4.5 Advanced menu

The Advanced menu items allow you to change the settings for the CPU and other system devices.



Take caution when changing the settings of the Advanced menu items. Incorrect field values can cause the system to malfunction.

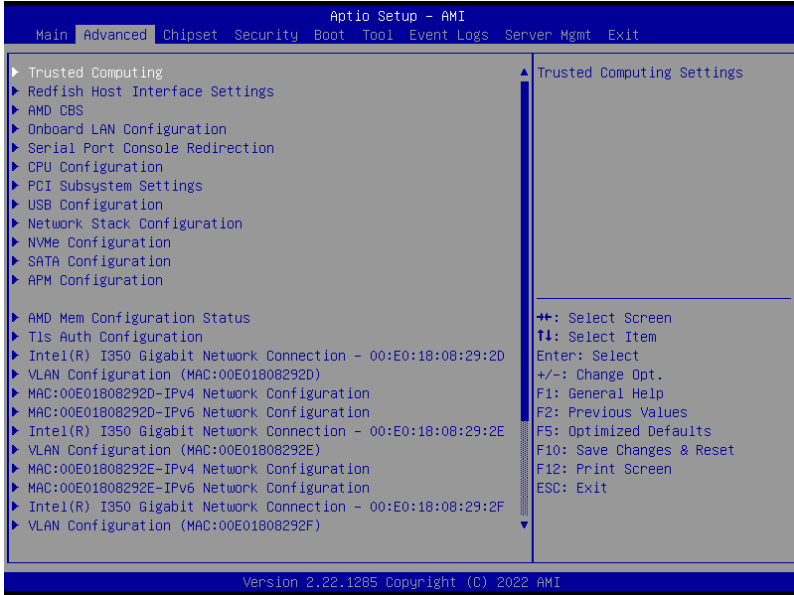

4.5.1 Trusted Computing

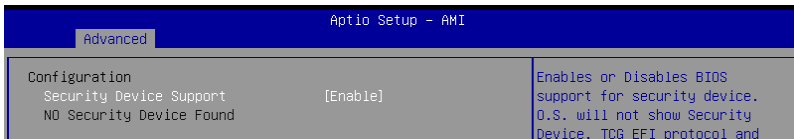

Configuration

Security Device Support [Enabled]

Allows you to enable or disable the BIOS support for security device. O.S. will not show Security Device. TCG EFI protocol and INT1A interface will not be available.

Configuration options: [Disabled] [Enabled]

4.5.2 Redfish Host Interface Settings

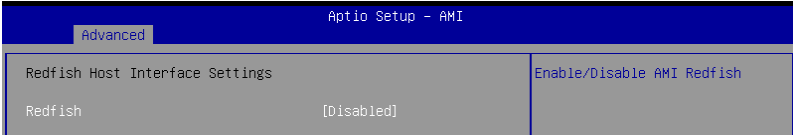

Redfish [Disabled]

Allows you to enable or disable Redfish.

Configuration options: [Disabled] [Enabled]



The following items appear only when **Redfish** is set to **[Enabled]**.

Authentication mode [Basic Authentication]

Allows you to select the authentication mode.

Configuration options: [Basic Authentication] [Session Authentication]

Redfish BMC Settings

IP address

Allows you to enter the IP address.

IP Mask address

Allows you to enter the IP Mask address.

IP Port

Allows you to enter the IP Port.

4.5.3 AMD CBS

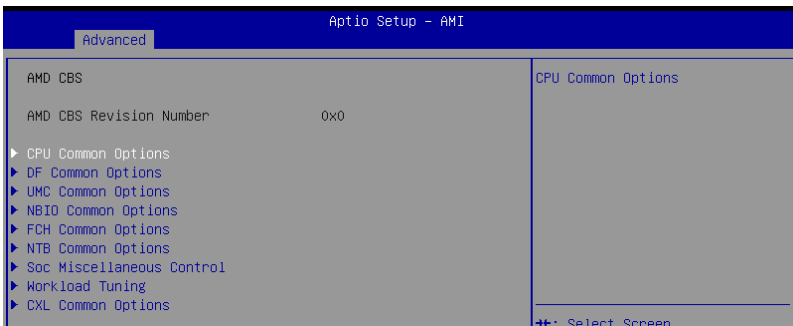

CPU Common Options

Performance

Allows you to configure performance options.

REP-MOV/STOS Streaming [Enabled]

Allows you to enable or disable the use of non-caching streaming stores for large sizes.

Configuration options: [Disabled] [Enabled]

Prefetcher Settings

Allows you to configure prefetcher options.

Core Watchdog

Allows you to configure core watchdog options.

RedirectForReturnDis [Auto]

Allows you to set RedirectForReturnDis to 0, 1, or Auto as a workaround for GCC/C000005 issue for XV Core on CZ A0.

Configuration options: [Auto] [1] [0]

Platform First Error Handling [Auto]

Allows you to enable or disable PFEH, cloak individual banks, and mask deferred error interrupts from each bank.

Configuration options: [Disabled] [Enabled] [Auto]

Core Performance Boost [Auto]

Configuration options: [Disabled] [Auto]

Global C-State Control [Auto]

Allows you to control IO based C-state generation and DF C-states.

Configuration options: [Disabled] [Enabled] [Auto]

Power Supply Idle Control [Auto]

Configuration options: [Low Current Idle] [Typical Current Idle] [Auto]

SEV-ES ASID Space Limit Control [Auto]

Configuration options: [Auto] [Manual]

SEV-ES ASID Space Limit [1]

SEV-ES and SNP guests must use ASIDs in the range 1 through (this value - 1). SEV guests must use ASIDs in the range of this value through 1006. To have all ASIDs support SEV-ES or SNP guests, set this value to 1007. The default is 1: all SEV guests and no SEV-ES or SNP guests.

Configuration options: [1] - [1007]

SEV Control [Enabled]

Can be used to disable SEV. To re-enable SEV, a power cycle is needed after selecting the [Enabled] option.

Configuration options: [Disabled] [Enabled]

Streaming Stores Control [Auto]

Configuration options: [Disabled] [Enabled] [Auto]

Local APIC Mode [Auto]

Configuration options: [Compatibility] [xAPIC] [x2APIC] [Auto]

ACPI _CST C1 Declaration [Auto]

Determines whether or not to declare the C1 state to the OS.
Configuration options: [Disabled] [Enabled] [Auto]

MCA Error Threshold Enable [Auto]

Configuration options: [False] [True] [Auto]

MCA FruText [Auto]

Configuration options: [False] [True]

SMU and PSP Debug Mode [Auto]

If this option is enabled, uncorrected errors detected by the PSP FW or SMU FW will hang and not reset the system instead of causing a cold reset.
Configuration options: [Disabled] [Enabled] [Auto]

PPIN Opt-in [Auto]

Configuration options: [Disabled] [Enabled] [Auto]

SNP Memory (RMP Table) Coverage [Auto]

When [Enabled] is selected, the entire system memory is covered.
Configuration options: [Disabled] [Enabled] [Custom] [Auto]



The following item appears only when **SNP Memory (RMP Table) Coverage** is set to **[Custom]**.

Amount of Memory to Cover [0]

Allows you to set the amount of system memory (MB) to be covered in hex.

SMEE [Auto]

Configuration options: [Disabled] [Enabled] [Auto]

Action on BIST Failure [Auto]

Allows you to configure what action is taken when a CCD BIST failure is detected.
Configuration options: [Do nothing] [Down-CCD] [Auto]

Enhanced Short REP MOVSB (ESRM) [Auto]

Configuration options: [Disabled] [Enabled] [Auto]

Log Transparent Errors [Auto]

Configuration options: [Disabled] [Enabled] [Auto]

AVX512 [Auto]

Configuration options: [Disabled] [Enabled] [Auto]

MONITOR and MWAIT Disable [Auto]

When this option is enabled, MONITOR, MWAIT, MONITORX, and MWAITX opcodes become invalid.
Configuration options: [Disabled] [Enabled] [Auto]

Small Hammer Configuration [Auto]

Configuration options: [Disabled] [Enabled] [Auto]

Corrector Branch Predictor [Disabled]

Enabling for branch heavy codes may reduce conditional branch mispredicts.
Configuration options: [Disabled] [Enabled]

CPU Speculative Store Modes [Auto]

- [Balanced] Store instructions may delay sending out their invalidations to remote cacheline copies when the cacheline is present but not in a writable state in the local cache.
- [More Speculative] Store instructions will send out invalidations to remote cacheline copies as soon as possible.
- [Less Speculative] Store instructions may delay sending out their invalidations to remote cacheline copies when the cacheline is not present in the local cache or not in a writable state in the local cache.
- [Auto] Default setting is applied.

PAUSE Delay [Auto]

Number of cycles thread will be idle after a PAUSE instruction.
Configuration options: [Auto] [Disabled] [16 cycles] [32 cycles] [64 cycles] [128 cycles]

DF Common Options

Memory Addressing

Allows you to configure memory addressing options.

ACPI

Allows you to configure ACPI options.

Link

Allows you to configure Link settings.

SDCI

Allows you to configure SDCI settings.

DF Watchdog Timer Interval [Auto]

Allows you to set the Data Fabric watchdog timer interval.
Configuration options: [Auto] [41ms] [166ms] [334ms] [669ms] [1.34 seconds] [2.68 seconds] [5.36 seconds]

Disable DF to external IP SyncFloodPropagation [Auto]

Allows you to enable or disable SyncFlood to UMC and downstream slaves.
Configuration options: [Sync flood disabled] [Sync flood enabled] [Auto]

Sync Flood Propagation to DF Components [Auto]

Configuration options: [Sync flood disabled] [Sync flood enabled] [Auto]

Freeze DF module queues on error [Auto]

Configuration options: [Disabled] [Enabled] [Auto]

CC6 Memory Region Encryption [Auto]

Configuration options: [Disabled] [Enabled] [Auto]

CCD B/W Balance Throttle Level [Auto]

Configuration options: [Auto] [Level 0] [Level 1] [Level 2] [Level 3] [Level 4]

UMC Common Options

DDR Addressing Options

Allows you to configure DDR addressing options.

DDR Controller Configuration

Allows you to configure DDR controller options.

DDR MBIST Options

Allows you to configure DDR MBIST options.

DDR RAS

Allows you to configure DDR RAS options.

DDR Bus Configuration

Allows you to configure DDR Bus options.

DDR Timing Configuration

Allows you to configure DDR Timing options.

DDR Training Options

Allows you to configure DDR Training options.

DDR Security

Allows you to configure DDR Security options.

DDR PMIC Configuration

Allows you to configure DDR PMIC options.

DDR Miscellaneous

Allows you to configure DDR Miscellaneous options.

NBIO Common Options

IOMMU [Auto]

Configuration options: [Disabled] [Enabled] [Auto]

DMAR Support [Auto]

Allows you to enable or disable DMAR system protection during POST.

Configuration options: [Disabled] [Enabled] [Auto]

DMA Protection [Auto]

Allows you to enable or disable DMA remap support in IVRS IVinfo Field.

Configuration options: [Auto] [Enabled] [Disabled]

DRTM Virtual Device Support [Auto]

Configuration options: [Disabled] [Enabled] [Auto]

DRTM Memory Reservation [Auto]

Allows you to enable or disable reservation of 128MB memory below Bottom IO for DRTM. This option is required for Secured-Core Server functionality.
Configuration options: [Disabled] [Enabled] [Auto]



The following item appears only when **Enable AER Cap** is set to **[Enabled]** or **[Auto]**.

ACS Enable [Auto]

Configuration options: [Disabled] [Enabled] [Auto]

PCIe ARI Support [Auto]

Configuration options: [Disabled] [Enabled] [Auto]

PCIe ARI Enumeration [Auto]

ARI Forwarding enabled for each downstream port.
Configuration options: [Disabled] [Enabled] [Auto]

PCIe Ten Bit Tag Support [Auto]

Allows you to enable PCIe ten bit tags for supported devices. Support is disabled if this option is set to **[Auto]**.
Configuration options: [Disabled] [Enabled] [Auto]

SMU Common Options

Allows you to configure SMU Common options.

NBIO RAS Common Options

Allows you to configure NBIO RAS Common options.

Enable AER Cap [Auto]

Configuration options: [Disabled] [Enabled] [Auto]

Early Link Speed [Auto]

Configuration options: [Auto] [Gen1] [Gen2]

Hot Plug Handling Mode [Auto]

Configuration options: [OS First] [Firmware First/EDR if OS supports]
[Firmware First but allow OS first] [System Firmware Intermediary] [Auto]

Hot Plug Allow FF in Synchronous [Disabled]

Allows firmware first hot plug handling mode to operate in mode A and mode B synchronous mappings.
Configuration options: [Disabled] [Enabled]

Presence Detect Select Mode [Auto]

Configuration options: [OR] [AND] [Auto]

Data Link Feature Cap [Auto]

Configuration options: [Disabled] [Enabled] [Auto]

CV Test [Auto]

Allows you to enable or disable support for PCIECV tool. Hardware defaults are preserved if this option is set to Auto.
Configuration options: [Disabled] [Enabled] [Auto]

SEV-SNP Support [Disabled]

Configuration options: [Disabled] [Enabled] [Auto]

Allow Compliance [Auto]

Allows you to enable or disable PCIe RP entering the polling compliance state.

Configuration options: [Disabled] [Enabled] [Auto]

SRIS [Auto]

Configuration options: [Disabled] [Enabled] [Auto]

Multi Upstream Auto Speed Change [Auto]

Defines the setting of this feature for all PCIe devices. When this option is set to [Auto], the DXIO default setting of 0 for Gen1 and 1 for Gen2/3 is applied.

Configuration options: [Disabled] [Enabled] [Auto]

Multi Auto Speed Change on Last Rate [Auto]

Force PCIe link training speed to last advertised for all ports.

[Disabled] Use highest data rate ever advertised.

[Enabled] Use last data rate advertised.

[Auto] Use default settings.

PCIe Link Speed Capability [GEN5]

Configuration options: [Maximum speed] [Gen1] [Gen2] [GEN3] [GEN4] [GEN5] [Auto]

RTM Margining Support [Auto]

Configuration options: [Disabled] [Enabled] [Auto]

Advertise EQ to High Rate Support [Auto]

Controls the ability to advertise Equalization Bypass to Highest Rate Support in TSxs sent prior to LinkUp=1.

Configuration options: [Disabled] [Enabled] [Auto]

nBif Common Options

Allows you to configure nBif Common options.

FCH Common Options

I3C/I2C Configuration Options

Allows you to configure I3C/I2C options.

SATA Configuration Options

Allows you to configure SATA options.

USB Configuration Options

Allows you to configure USB options.

Ac Power Loss Options

Allows you to configure AC power loss options.

UART Configuration Options

Allows you to configure UART options.

ESPI Configuration Options

Allows you to configure ESPI options.

FCH RAS Options

Allows you to configure FCH RAS options.

Miscellaneous Options

Allows you to configure miscellaneous FCH options.

NTB Common Options

Socket-0 P0 NTB Enable [Auto]

Configuration options: [Disabled] [Enabled] [Auto]

Socket-0 P2 NTB Enable [Auto]

Configuration options: [Disabled] [Enabled] [Auto]

Socket-0 G0 NTB Enable [Auto]

Configuration options: [Disabled] [Enabled] [Auto]

Socket-0 G2 NTB Enable [Auto]

Configuration options: [Disabled] [Enabled] [Auto]

Soc Miscellaneous Control

ABL Console Out Control [Auto]

[Disabled] Disable ConsoleOut Function for ABL.

[Enabled] Enable ConsoleOut Function for ABL.

[Auto] Keep default behavior.



The following items appear only when **ABL Console Out Control** is set to **[Enabled]**.

ABL Console Out Serial Port

[eSPI UART] Enable serial port through eSPI UART.

[SOC UART0] Enable serial port through SOC UART0.

[SOC UART1] Enable serial port through SOC UART1.

[Auto] Keep default behavior.



The following item appears only when **ABL Console Out Serial Port** is set to **[eSPI UART]**.

ABL Console Out Serial Port IO

Select Legacy Uart (SIO or eSPI) IO base.

Configuration options: [0x3F8] [0x2F8] [0x3E8] [0x2E8] [Auto]

ABL Basic Console Out Control

[Disabled] Disable Basic ConsoleOut Function for ABL.

[Enabled] Enable Basic ConsoleOut Function for ABL.

[Auto] Keep default behavior.

ABL PMU message Control

Allows you to control the total number of PMU debug messages.

Configuration options: [Detailed debug message] [Coarse debug message] [Stage completion] [Assertion messages] [Firmware completion message only] [Auto]

ABL Memory Population message Control

Non-recommended configurations may be functional but may not be validated by AMD.

[Warning message] Show warning messages if Memory channel configuration does NOT follow SP5 Memory Population Guidelines.

[Fatal error] Show warning messages and halt system.

PSP error injection support

Configuration options: [False] [True]

Firmware Anti-rollback (FAR)

Allows you to configure Firmware Anti-rollback (FAR) options.

Workload Tuning

Workload Profile

[Disabled]	Don't use any workload profiles.
[CPU Intensive]	Tuned for CPU intensive workloads, providing optimal integer and floating point performance.
[Java Throughput]	Tuned for the highest level of throughput with Java workloads.
[Java Latency]	Tuned for the latency sensitive Java workloads, to meet critical SLA's.
[Power Efficiency]	Tuned for optimal power efficiency.
[Memory Throughput Intensive]	Tuned for the highest memory throughput available.
[Storage IO Intensive]	Tuned for the highest storage IO bandwidth.
[NIC Throughput Intensive]	Tuned for maximum TCP/IP and RDMA network throughput.
[NIC Latency Sensitive]	Tuned for network performance where the kernel preforms L3 packet forwarding.
[Accelerator Throughput]	Tuned to maximum peer-to-peer PCIe throughput with accelerators such as GPUs.
[VMware vSphere Optimized]	Tuned for general virt+P3+Q4.
[Linux KVM Optimized]	Tuned for general virtualization performance when using Linux KVM.
[Container Optimized]	Optimized for container performance.
[RDBMS Optimized]	Tuned for relational databases.
[Big Data Analytics Optimized]	Tuned for big data analytics.
[IOT Gateway]	Tuned for throughput analytics as observed by IOT gateways.
[HPC Optimized]	Tuned for general HPC performance.
[OpenStack NFV]	Tuned for Openstack based NFV workloads.
[OpenStack for RealTime Kernel]	Tuned for OpenStack with RealTime kernel enabled.
[Auto]	Uses BIOS default workload profile.

Performance Tracing

Configuration options: [Disabled] [Enabled] [Auto]

CXL Common Options



For an AVL of components that support CXL, please contact your sales representative.

CXL Control

Configuration options: [Disabled] [Enabled] [Auto]

CXL SPM

Set CXL memory as Special Purpose Memory.
Configuration options: [Disabled] [Enabled] [Auto]

CXL ASPM

Configuration options: [Disabled] [Enabled] [Auto]

CXL vLSM Power Management

Allows you to configure CXL vLSM Power Management options.

CXL Encryption

Configuration options: [Disabled] [Enabled]

Temp Gen5 Advertisement

Configuration options: [Disabled] [Enabled] [Auto]

4.5.4 Onboard LAN Configuration



The items in this menu will vary depending on the LAN card installed.

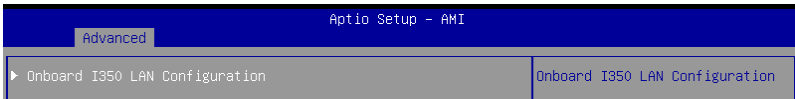

The following items appear only when an Intel® I350 1G LAN card is installed.

Onboard I350 LAN Configuration

Intel I350 LAN1-4

LAN Enable [JumperState]

Allows you to enable or disable the Intel LAN.
Configuration options: [Disabled] [JumperState]

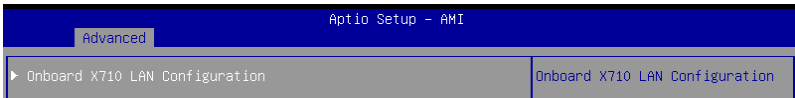

The following items appear only when an Intel® X710 10G LAN card is installed.

Onboard X710 LAN Configuration

Intel X710 LAN1-2

LAN Enable [JumperState]

Allows you to enable or disable the Intel LAN.
Configuration options: [Disabled] [JumperState]

4.5.5 Serial Port Console Redirection

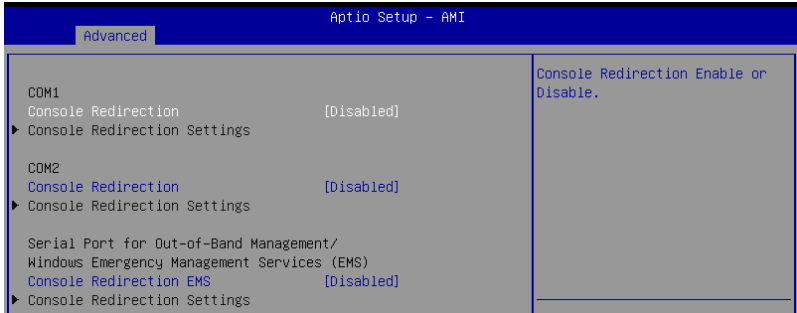

COM1/COM2

Console Redirection [Disabled]

Allows you to enable or disable the console redirection feature.

Configuration options: [Disabled] [Enabled]



The following item appears only when **Console Redirection** is set to **[Enabled]**.

Console Redirection Settings

These items become configurable only when you enable the **Console Redirection** item. The settings specify how the host computer and the remote computer (which the user is using) will exchange data. Both computers should have the same or compatible settings.

Terminal Type [ANSI]

Allows you to set the terminal type.

[VT100] ASCII char set.

[VT100PLUS] Extends VT100 to support color, function keys, etc.

[VT-UTF8] Uses UTF8 encoding to map Unicode chars onto 1 or more bytes.

[ANSI] Extended ASCII char set.

Bits per second [115200]

Selects serial port transmission speed. The speed must be matched on the other side. Long or noisy lines may require lower speeds.

Configuration options: [9600] [19200] [38400] [57600] [115200]

Data Bits [8]

Configuration options: [7] [8]

Parity [None]

A parity bit can be sent with the data bits to detect some transmission errors. [Mark] and [Space] parity do not allow for error detection.

[None]	None
[Even]	parity bit is 0 if the num of 1's in the data bits is even
[Odd]	parity bit is 0 if num of 1's in the data bits is odd
[Mark]	parity bit is always 1
[Space]	parity bit is always 0

Stop Bits [1]

Stop bits indicate the end of a serial data packet. (A start bit indicates the beginning.) The standard setting is 1 stop bit. Communication with slow devices may require more than 1 stop bit.

Configuration options: [1] [2]

Flow Control [None]

Flow control can prevent data loss from buffer overflow. When sending data, if the receiving buffers are full, a "stop" signal can be sent to stop the data flow. Once the buffers are empty, a "start" signal can be sent to re-start the flow. Hardware flow control uses two wires to send start/stop signals.

Configuration options: [None] [Hardware RTS/CTS]

VT -UTF8 Combo Key Support [Enabled]

This allows you to enable the VT -UTF8 Combination Key Support for ANSI/VT100 terminals.

Configuration options: [Disabled] [Enabled]

Recorder Mode [Disabled]

With this mode enabled only text will be sent. This is to capture Terminal data.

Configuration options: [Disabled] [Enabled]

Resolution 100x31 [Enabled]

This allows you enable or disable extended terminal resolution.

Configuration options: [Disabled] [Enabled]

Putty Keypad [VT100]

This allows you to select the FunctionKey and Keypad on Putty.

Configuration options: [VT100] [LINUX] [XTERMR6] [SCO] [ESCN] [VT400]

Serial Port for Out-of-Band Management/ Windows Emergency Management Services (EMS)

Console Redirection [Disabled]

Allows you to enable or disable the console redirection feature.

Configuration options: [Disabled] [Enabled]



The following item appears only when **Console Redirection** is set to **[Enabled]**.

Console Redirection Settings

Out-of-Band Mgmt Port [COM1]

Microsoft Windows Emergency Management Services (EMS) allow for remote management of a Windows Server OS through a serial port.

Configuration options: [COM1] [COM2]

Terminal Type [VT-UTF8]

Microsoft Windows Emergency Management Services (EMS) allow for remote management of a Windows Server OS through a serial port.

Configuration options: [VT100] [VT100PLUS] [VT-UTF8] [ANSI]

Bits per second [115200]

Microsoft Windows Emergency Management Services (EMS) allow for remote management of a Windows Server OS through a serial port.

Configuration options: [9600] [19200] [57600] [115200]

Flow Control [None]

Microsoft Windows Emergency Management Services (EMS) allow for remote management of a Windows Server OS through a serial port.

Configuration options: [None] [Hardware RTS/CTS] [Software Xon/Xoff]

4.5.6 CPU Configuration

This page displays the CPU node information.

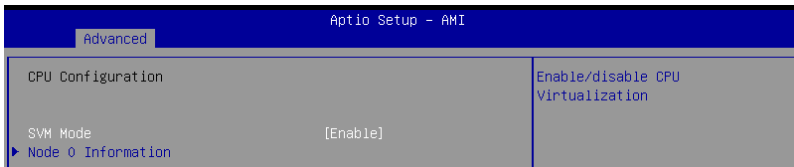

SVM Mode [Enabled]

This item allows you enable or disable CPU Virtualization.

Configuration options: [Disabled] [Enabled]

Node 0 Information

This item allows you to view memory information related to Node 0.

4.5.7 PCI Subsystem Settings

Allows you to configure PCI, PCI-X, and PCI Express Settings.

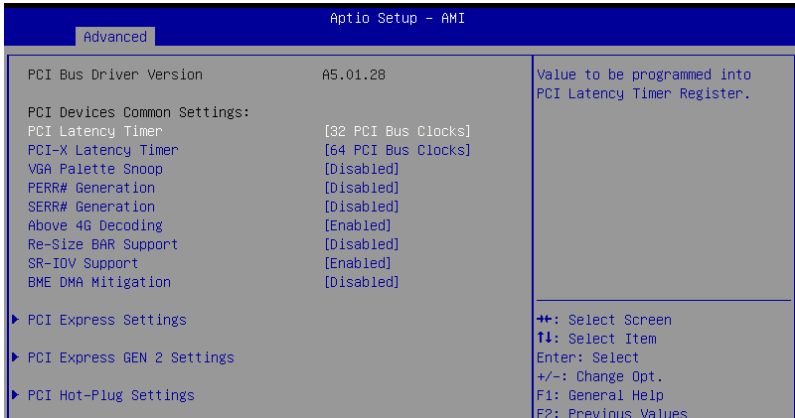

PCI Latency Timer [32 PCI Bus Clocks]

Configuration options: [32 PCI Bus Clocks] [64 PCI Bus Clocks] [96 PCI Bus Clocks] [128 PCI Bus Clocks] [160 PCI Bus Clocks] [192 PCI Bus Clocks] [224 PCI Bus Clocks] [248 PCI Bus Clocks]

PCI-X Latency Timer [64 PCI Bus Clocks]

Configuration options: [32 PCI Bus Clocks] [64 PCI Bus Clocks] [96 PCI Bus Clocks] [128 PCI Bus Clocks] [160 PCI Bus Clocks] [192 PCI Bus Clocks] [224 PCI Bus Clocks] [248 PCI Bus Clocks]

VGA Palette Snoop [Disabled]

Configuration options: [Disabled] [Enabled]

PERR# Generation [Disabled]

Configuration options: [Disabled] [Enabled]

SERR# Generation [Disabled]

Configuration options: [Disabled] [Enabled]

Above 4G Decoding [Enabled]

Allows you to enable or disable 64-bit capable devices to be decoded in above 4G address space. It only works if the system supports 64-bit PCI decoding.

Configuration options: [Disabled] [Enabled]

Re-Size BAR Support [Disabled]

Configuration options: [Disabled] [Auto]



This option only comes into effect if the system has Resizable BAR capable PCIe devices.

SR-IOV Support [Enabled]

This option enables or disables Single Root IO Virtualization Support if the system has SR-IOV capable PCIe devices.

Configuration options: [Disabled] [Enabled]

BME DMA Mitigation [Disabled]

This allows you to enable or disable re-enabling Bus Master Attribute disabled during Pci enumeration for PCI Bridges after SMM locked.

Configuration options: [Disabled] [Enabled]

PCI Express Settings

PCI Express Device Register Settings

Relaxed Ordering [Enabled]

Configuration options: [Disabled] [Enabled]

Extended Tag [Disabled]

If this item is enabled, it will allow Device to use 8-bit Tag field as a requester.

Configuration options: [Disabled] [Enabled]

No Snoop [Enabled]

Configuration options: [Disabled] [Enabled]

Maximum Payload [Auto]

Allows you to set Maximum Payload of PCI Express Device or allow System BIOS to select the value.

Configuration options: [Auto] [128 Bytes] [256 Bytes] [512 Bytes] [1024 Bytes] [2048 Bytes] [4096 Bytes]

Maximum Read Request [Auto]

Allows you to set Maximum Read Request Size of PCI Express Device or allow System BIOS to select the value.

Configuration options: [Auto] [128 Bytes] [256 Bytes] [512 Bytes] [1024 Bytes] [2048 Bytes] [4096 Bytes]

PCI Express Link Register Settings

ASPM Support [Disabled]

Allows you to set the ASPM level.

[Disabled] Disables ASPM.

[Auto] BIOS auto configure.

[Force L0s] Force all links to L0 State.



Enabling ASPM may cause some PCI-E devices to fail.

Extended Synch [Disabled]

If this item is enabled, it will allow generation of Extended Synchronization patterns.

Configuration options: [Disabled] [Enabled]

Link Training Retry [5]

Allows you to define the number of Retry Attempts software will take to retrain the link if previous training attempt was unsuccessful.

Configuration options: [Disabled] [2] [3] [5]

Link Training Timeout (uS) [1000]

Allows you to define the number of Microseconds software will wait before polling 'link Training' bit in Link Status register.

Configuration options: [10] - [10000]

Unpopulated Links [Keep Link ON]

If this option is set to **[Disable Link]**, in order to save power, software will disable unpopulated PCI Express Links.

Configuration options: [Keep Link ON] [Disabled Link]

PCI Express GEN 2 Settings

The items in this submenu allow you change PCI Express GEN Devices Settings.

PCI Express GEN2 Device Register Settings

Completion Timeout [Default]

In device Functions that support Completion Timeout programmability, allows system software to modify the Completion Timeout value.

[Default] 50us to 50ms.

[Shorter] Software will use shorter timeout ranges supported by hardware.

[Longer] Software will use longer timeout ranges.

[Disabled] Disable completion timeout.

ARI Forwarding [Disabled]

If supported by hardware and set to **[Enabled]**, the Downstream Port disables its traditional Device Number field being 0 enforcement when turning a Type1 Configuration Request into a Type0 Configuration Request, permitting access to Extended Functions in an ARI Device immediately below the Port.

Configuration options: [Disabled] [Enabled]

Atomic0p Requester Enable [Disabled]

If supported by hardware and set to **[Enabled]**, this function initiates Atomic0p Requests only if Bus Master Enable bit is in the Command Register Set.

Configuration options: [Disabled] [Enabled]

Atomic0p Egress Blocking [Disabled]

If supported by hardware and set to **[Enabled]**, outbound Atomic0p Requests via Egress Ports will be blocked.

Configuration options: [Disabled] [Enabled]

IDO Request Enable [Disabled]

If supported by hardware and set to **[Enabled]**, this permits setting the number of ID-Based Ordering (IDO) bit (Attribute[2]) requests to be initiated.

Configuration options: [Disabled] [Enabled]

IDO Completion Enable [Disabled]

If supported by hardware and set to **[Enabled]**, this permits setting the number of ID-Based Ordering (IDO) bit (Attribute[2]) requests to be initiated.

Configuration options: [Disabled] [Enabled]

LTR Mechanism Enable [Disabled]

If supported by hardware and set to **[Enabled]**, this enables the Latency Tolerance Reporting (LTR) Mechanism.

Configuration options: [Disabled] [Enabled]

End-End TLP Prefix Blocking [Disabled]

If supported by hardware and set to **[Enabled]**, this function will block forwarding of TLPs containing End-End TLP Prefixes.

Configuration options: [Disabled] [Enabled]

PCI Express GEN2 Link Register Settings

Target Link Speed [Auto]

If supported by hardware and set to **[Force to X.X GT/s]**, for Downstream Ports, this sets an upper limit on Link operational speed by restricting the values advertised by the Upstream component in its training sequences. When **[Auto]** is selected HW initialized data will be used.

Configuration options: [Disabled] [Force to 2.5 GT/s] [Force to 5.0 GT/s] [Force to 8.0 GT/s] [Force to 16.0 GT/s] [Force to 32.0 GT/s]

Clock Power Management [Disabled]

If supported by hardware and set to **[Enabled]**, the device is permitted to use CLKREQ# signal for power management of Link clock in accordance to protocol defined in appropriate form factor specification.

Configuration options: [Disabled] [Enabled]

Compliance SOS [Disabled]

If supported by hardware and set to **[Enabled]**, this will force LTSSM to send SKP Ordered Sets between sequences when sending Compliance Pattern or Modified Compliance Pattern.

Configuration options: [Disabled] [Enabled]

Hardware Autonomous Width [Enabled]

If supported by hardware and set to **[Disabled]**, this will disable the hardware's ability to change link width except width size reduction for the purpose of correcting unstable link operation.

Configuration options: [Disabled] [Enabled]

Hardware Autonomous Speed [Enabled]

If supported by hardware and set to **[Disabled]**, this will disable the hardware's ability to change link speed except speed rate reduction for the purpose of correcting unstable link operation.

Configuration options: [Disabled] [Enabled]

PCI Hot-Plug Settings

The items in this submenu allow you change PCI Express Hot-Plug and Standard HP Controller Settings.

BIOS Hot-Plug Support [Enabled]

If this item is enabled, it allows the BIOS built-in Hot-Plug support to be used.. Use this feature if OS does not support PCI Express and SHPC hot-plug natively.

Configuration options: [Disabled] [Enabled]



The following items appear only when **BIOS Hot-Plug Support** is set to **[Enabled]**.

PCI Buses Padding [1]

Configuration options: [Disabled] [1] - [5]

I/O Resources Padding [4 K]

Configuration options: [Disabled] [4 K] [8 K] [16 K] [32 K]

MMIO 32 bit Resources Padding [64 M]

Configuration options: [Disabled] [1 M] [2 M] [4 M] [8 M] [16 M] [32 M] [64 M] [128 M]

PFMMIO 32 bit Resources Padding [16 M]

Configuration options: [Disabled] [1 M] [2 M] [4 M] [8 M] [16 M] [32 M] [64 M] [128 M]

PFMMIO 64 bit Resources Padding [Disabled]

Configuration options: [Disabled] [1 M] [2 M] [4 M] [8 M] [16 M] [32 M] [64 M] [128 M] [256 M] [512 M] [1 G] [2 G] [4 G] [8 G]



Due to the Bridge Architecture Specification Software, selected padding for 64 and 32 bit PFMMIO window cannot be applied at the same time. User must pick choose which PFMMIO they want to pad by setting the other resource to the disabled state. If both PFMMIO is set, the 32 bit resource will be used.

4.5.8 USB Configuration

Advanced		Aptio Setup - AMI	
USB Configuration		[Enabled]: Enables the Legacy USB support.	
USB Module Version	29	[Auto]: Automatically disables the Legacy USB support if USB devices are not connected.	
USB Controllers: 2 XHCIs		[Disabled]: USB devices are available only for EFI applications.	
USB Devices: 3 Drives, 3 Keyboards, 2 Mice, 3 Hubs			
Legacy USB Support	[Enabled]		
XHCI Hand-off	[Enabled]		
USB Mass Storage Driver Support	[Enabled]		
USB Keyboard and Mouse Simulator	[Enabled]		
USB hardware delays and time-outs:		++: Select Screen F1: Select Item Enter: Select +/-: Change Opt. F1: General Help F2: Previous Values F5: Optimized Defaults F10: Save Changes & Reset F12: Print Screen ESC: Exit	
USB transfer time-out	[20 sec]		
Device reset time-out	[20 sec]		
Device power-up delay	[Auto]		
Mass Storage Devices:			
JetFlashTranscend 4GB 8.07	[Auto]		
AMI Virtual CDROM 1.00	[Auto]		
AMI Virtual HDisk 1.00	[Auto]		

Legacy USB Support [Enabled]

- [Disabled] USB devices are available only for EFI applications.
- [Enabled] Enables the support for USB devices on legacy operating systems (OS).
- [Auto] Automatically disables the Legacy USB support if USB devices are not connected.

XHCI Hand-off [Enabled]

Allows you to enable or disable workaround for OSes without XHCI hand-off support. The XHCI ownership change should be claimed by XHCI driver.
 Configuration options: [Enabled] [Disabled]

USB Mass Storage Driver Support [Enabled]

Configuration options: [Disabled] [Enabled]

USB Keyboard and Mouse Simulator [Enabled]

Enable this item to simulate USB keyboard and mouse to PS/2 module in Windows 7. Ensure to install the USB drivers to your system before disabling this item.
 Configuration options: [Disabled] [Enabled]

USB hardware delays and time-outs

USB transfer time-out [20 sec]

Allows you to select time-out value for Control, Bulk, and Interrupt transfers.
 Configuration options: [1 sec] [5 sec] [10 sec] [20 sec]

Device reset time-out [20 sec]

Configuration options: [10 sec] [20 sec] [30 sec] [40 sec]

Device power-up delay [Auto]

Maximum time the device will take before it properly reports itself to the Host Controller.

[Auto] Uses default value; for a Root port it is 100 ms, for a Hub port the delay is taken from Hub descriptor.

[Manual] Manually set the device power-up delay.



The following item appears only when **Device power-up delay** is set to **[Manual]**.

Device power-up delay in seconds [5]

Allows you to set the device power-up delay in seconds. Use the <+> or <-> to adjust the value. The values range from 1 to 40.

Mass Storage Devices

Allows you to select the mass storage device emulation type for devices connected.

Configuration options: [Auto] [Floppy] [Forced FDD] [Hard Disk] [CD-ROM]

4.5.9 Network Stack Configuration

Aptio Setup - AMI		
Advanced		
Network Stack	[Enabled]	Enable/Disable UEFI Network Stack
IPv4 PXE Support	[Disabled]	
IPv4 HTTP Support	[Disabled]	
IPv6 PXE Support	[Disabled]	
IPv6 HTTP Support	[Disabled]	
PXE boot wait time	0	
Media detect count	1	

Network stack [Enabled]

Enables or disables the network stack feature.

Configuration options: [Disabled] [Enabled]



The following item appears only when **Network stack** is set to **[Enabled]**.

Ipv4 PXE Support [Disabled]

Enables or disables the Ipv4 PXE Boot Support. If disabled, Ipv4 PXE boot option will not be created.

Configuration options: [Disabled] [Enabled]

Ipv4 HTTP Support [Disabled]

Enables or disables the Ipv4 HTTP Boot Support. If disabled, Ipv4 HTTP boot option will not be created.

Configuration options: [Disabled] [Enabled]

Ipv6 PXE Support [Disabled]

Enables or disables the Ipv6 PXE Boot Support. If disabled, Ipv6 PXE boot option will not be created.

Configuration options: [Disabled] [Enabled]

Ipv6 HTTP Support [Disabled]

Enables or disables the Ipv6 HTTP Boot Support. If disabled, Ipv6 HTTP boot option will not be created.

Configuration options: [Disabled] [Enabled]

PXE boot wait time [0]

Set the wait time to press ESC key to abort the PXE boot. Use the <+> or <-> to adjust the value. The values range from 0 to 5.

Media detect count [1]

Set the number of times presence of media will be checked. Use the <+> or <-> to adjust the value. The values range from 1 to 50.

4.5.10 NVMe Configuration

This page will display the NVMe controller and drive information. You may press <Enter> on a connected NVMe device which appears in this menu to view more information on the NVMe device.

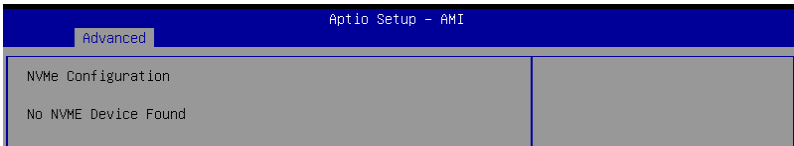

Device



The devices and names shown in the NVMe configuration list depends on the connected devices. If no devices are connected, **No NVMe Device Found** will be displayed.

Self Test Option [Short]

This option allows you to select either Short or Extended Self Test. Short option will take couple of minutes, and the extended option will take several minutes to complete.

Configuration options: [Short] [Extended]

Self Test Action [Controller Only Test]

This item allows you to select either to test Controller alone or Controller and NameSpace. Selecting Controller and NameSpace option will take a lot longer to complete the test.

Configuration options: [Controller Only Test] [Controller and NameSpace Test]

Run Device Self Test

Press <Enter> to perform device self test for the corresponding Option and Action selected by the user. Pressing the <ESC> key will abort the test. The results shown below is the most recent result logged in the device.

4.5.11 SATA Configuration

This page will display the SATA controller and drive information.

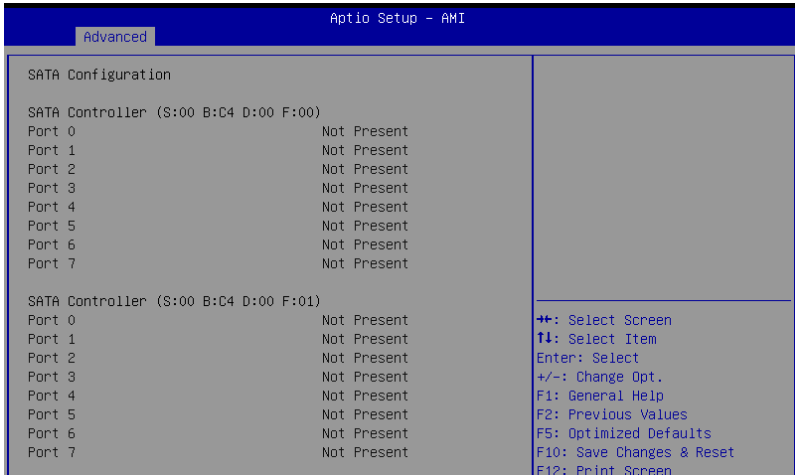

4.5.12 APM Configuration

Allows you to configure the Advance Power Management (APM) settings.

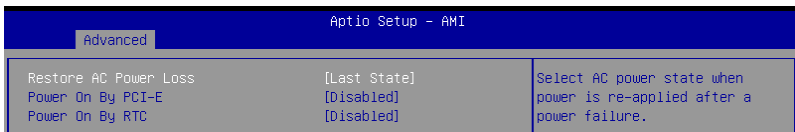

Restore AC Power Loss [Last State]

When set to [Power Off], the system goes into off state after an AC power loss. When set to [Power On], the system will reboot after an AC power loss. When set to [Last State], the system goes into either off or on state, whatever the system state was before the AC power loss.

Configuration options: [Power On] [Power Off] [Last State]

Power On By PCI-E [Disabled]

[Disabled] Disables the PCIE devices to generate a wake event.

[Enabled] Enables the PCIE devices to generate a wake event.

Power On By RTC [Disabled]

[Disabled] Disables RTC to generate a wake event.

[Enabled] When set to [Enabled], the items **RTC Alarm Date (Days)** and **Hour/Minute/Second** will become user-configurable with set values.

4.5.13 AMD Mem Configuration Status

The items in this menu display the memory configuration (initialized by ABL) status.

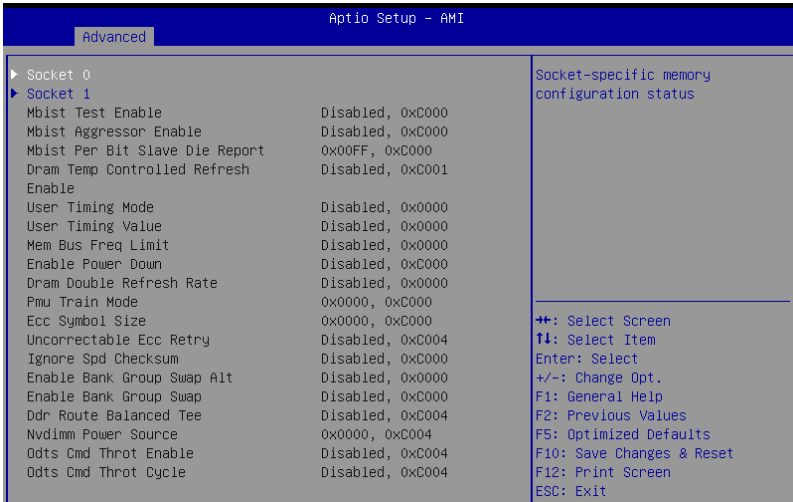

Socket 0-1

Allows you to view and configure Socket-specific memory configuration status options.

4.5.14 T1s Auth

Allows you to configure the Server Certificate Authority (CA).



Server CA Configuration / Client Cert Configuration

Enroll Cert

Allows you to enroll a certificate using a certificate file or manually input a certificate GUID.

Enroll Cert Using File

Allows you to enroll a certificate using a certificate file. You will be prompted to select a storage device and navigate to the location of the certificate file.

Cert GUID

Allows you to enroll a certificate by manually inputting the certificate GUID.

Commit Changes and Exit

Exit Server CA configuration after saving the changes.

Discard Changes and Exit

Exit Server CA configuration without saving any changes.

Delete Cert

Allows you to delete the certificate.

4.5.15 Driver Health

Provides Health Status for the Drivers/Controllers.

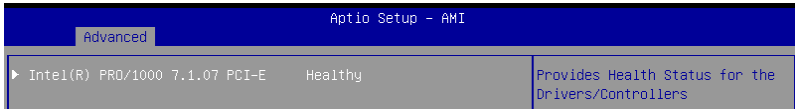

4.5.16 Third-party UEFI driver configurations

Additional configuration options for third-party UEFI drivers installed to the system will appear in the bottom of the Advanced menu, in the section marked red in the screenshot below.

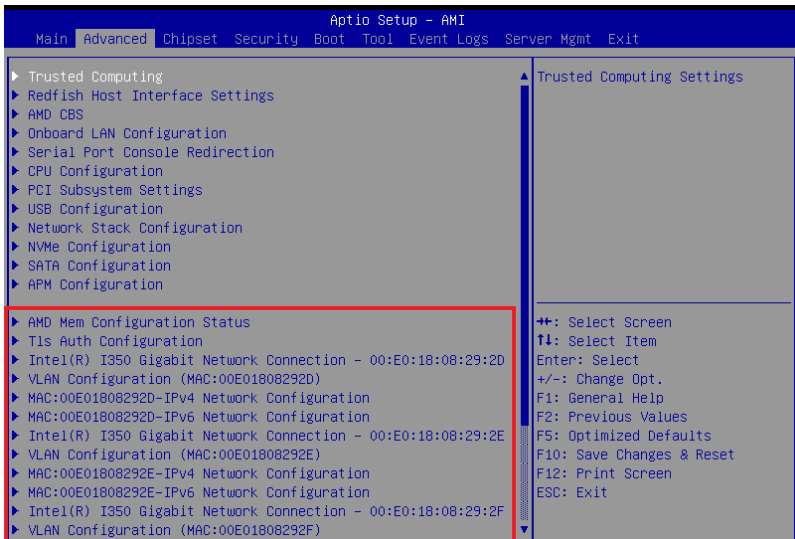

4.6 Chipset menu

The Chipset menu items allow you to change the Chipset settings.



PCIe Link Training Type [1 Step]

This item allows you to select PCIe Link Training in 1 or 2 steps.

Configuration options: [1 Step] [2 Step]

PCIe Compliance Mode [Off]

Configuration options: [Off] [On]

System Agent (SA) Configuration

Socket 1 Information

This item displays the memory information on Socket 1.

4.7 Security menu

This menu allows a new password to be created or a current password to be changed. The menu also enables or disables the Secure Boot state and lets the user configure the System Mode state.

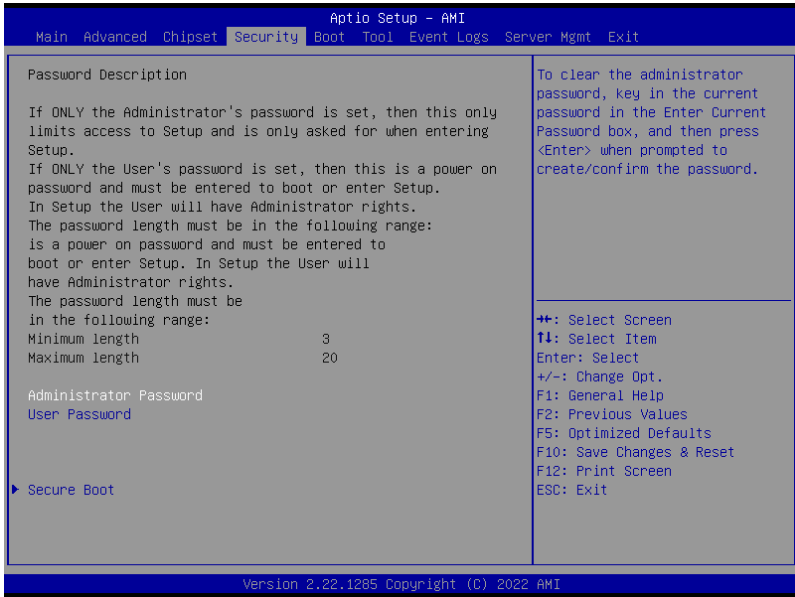

Administrator Password

To set an administrator password:

1. Select the Administrator Password item and press <Enter>.
2. From the Create New Password box, key in a password, then press <Enter>.
3. Confirm the password when prompted.

To change an administrator password:

1. Select the Administrator Password item and press <Enter>.
2. From the Enter Current Password box, key in the current password, then press <Enter>.
3. From the Create New Password box, key in a new password, then press <Enter>.
4. Confirm the password when prompted.



To clear the administrator password, follow the same steps as in changing an administrator password, but press <Enter> when prompted to create/confirm the password.

User Password

To set a user password:

1. Select the User Password item and press <Enter>.
2. From the Create New Password box, key in a password, then press <Enter>.
3. Confirm the password when prompted.

To change a user password:

1. Select the User Password item and press <Enter>.
2. From the Enter Current Password box, key in the current password, then press <Enter>.
3. From the Create New Password box, key in a new password, then press <Enter>.
4. Confirm the password when prompted.

To clear a user password:

1. Select the Clear User Password item and press <Enter>.
2. Select **Yes** from the Warning message window then press <Enter>.

Secure Boot

This item allows you to customize the Secure Boot settings.

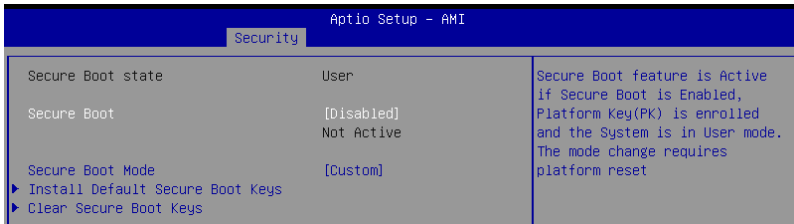

Secure Boot [Disabled]

Secure Boot feature is Active if Secure Boot is Enabled, Platform Key (PK) is enrolled, and the System is in User mode. A mode change requires a platform reset.

Configuration options: [Disabled] [Enabled]

Secure Boot Mode [Custom]

Allows you to set the Secure Boot selector. In Custom mode, Secure Boot Policy variables can be configured physically by the present user without full authentication.

Configuration options: [Custom] [Standard]



The following items are only available when **Secure Boot Mode** is set to **[Custom]**.

Install Default Secure Boot Keys

This option will load the default secure boot keys, including the PK (Platform key), KEK (key-exchange key), db (signature database), and dbx (revoked signature database). All the secure boot keys states will change from unloaded to loaded. Save changes and reset the system for the changes to take effect.

Clear Secure Boot Keys

This option will delete all previously applied secure boot keys, including the PK (Platform key), KEK (key-exchange key), db (signature database), and dbx (revoked signature database). All the secure boot keys states will change from unloaded to loaded. Save changes and reset the system for the changes to take effect.

Key Management

The Key Management item allows you to modify Secure Boot variables and set Key Management page.

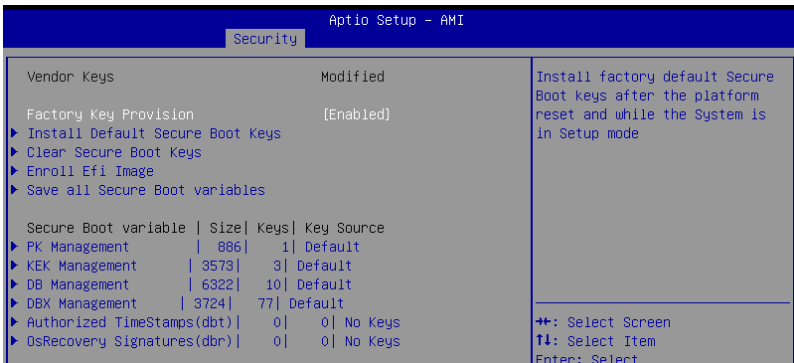

Factory Key Provision [Enabled]

Allows you to provision factory default Secure Boot keys after the platform resets and while the system is in Setup Mode.

Configuration options: [Disabled] [Enabled]

Install Default Secure Boot Keys

This option will load the default secure boot keys, including the PK (Platform key), KEK (key-exchange key), db (signature database), and dbx (revoked signature database). All the secure boot keys states will change from unloaded to loaded. Save changes and reset the system for the changes to take effect.

Clear Secure Boot Keys

This option will delete all previously applied secure boot keys, including the PK (Platform key), KEK (key-exchange key), db (signature database), and dbx (revoked signature database). All the secure boot keys states will change from unloaded to loaded. Save changes and reset the system for the changes to take effect.

Enroll Efi Image

This item will allow the image to run in Secure Boot mode. Enroll SHA256 Hash certificate of a PE image into Authorized Signature Database (db).

Save all Secure Boot Variables

This option will save NVRAM content of Secure Boot policy variables to the file (EFI_SIGNATURE_LIST data format) in root folder on a target file system device.

PK Management

Configuration options: [Details] [Save To File] [Set New Key] [Delete key]

KEK Management / DB Management / DBX Management

Configuration options: [Details] [Save To File] [Set New Key] [Append Key] [Delete key]

Authorized TimeStamps (dbt) / OsRecovery Signatures (dbr)

Configuration options: [Set New Key] [Append Key]

4.8 Boot menu

The Boot menu items allow you to change the system boot options.

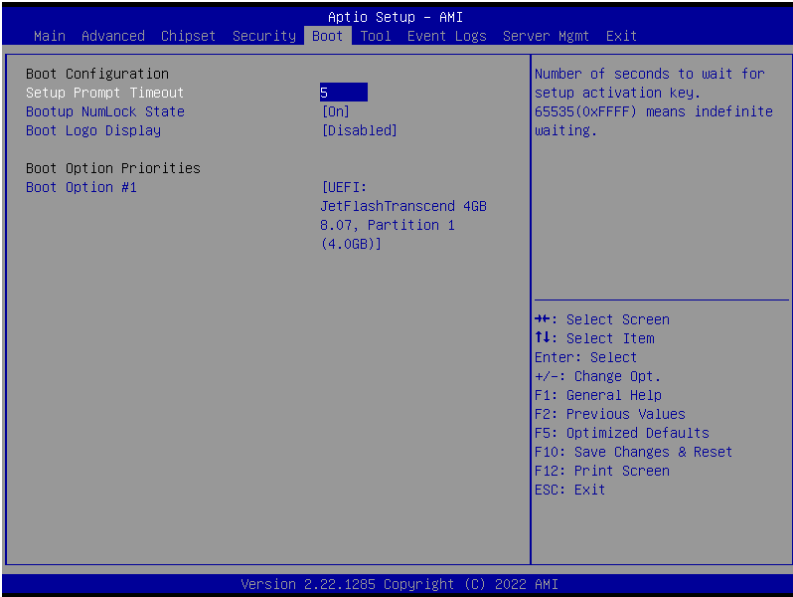

Setup Prompt Timeout [5]

Allows you to set the number of seconds that the firmware waits before initiating the original default boot selection. 65535(0xFFFF) means indefinite waiting. Use the <+> or <-> to adjust the value.

Bootup NumLock State [On]

Configuration options: [Off] [On]

Boot Logo Display [Disabled]

[Disabled] Hide the logo during POST.

[Enabled] Display the boot logo during POST.

Boot Option Priorities

These items specify the boot device priority sequence from the available devices. The number of device items that appears on the screen depends on the number of devices installed in the system.



- To select the boot device during system startup, press <F8> when ASUS Logo appears.
- To access Windows OS in Safe Mode, please press <F8> after POST.

4.9 Tool menu

The Tool menu items allow you to configure options for special functions. Select an item then press <Enter> to display the submenu.



Start ASUS EzFlash

Allows you to run ASUS EzFlash BIOS ROM Utility when you press <Enter>. Refer to the **ASUS EzFlash Utility** section for details.

IPMI Hardware Monitor

Allows you to run the IPMI hardware monitor.

ASUS SMBIOS Viewer

Allows you to run ASUS SMBIOS Viewer.

ASUS Storage Viewer

Allows you to run ASUS Storage Viewer.

4.10 Event Logs menu

The Event Logs menu items allow you to change the event log settings and view the system event logs.

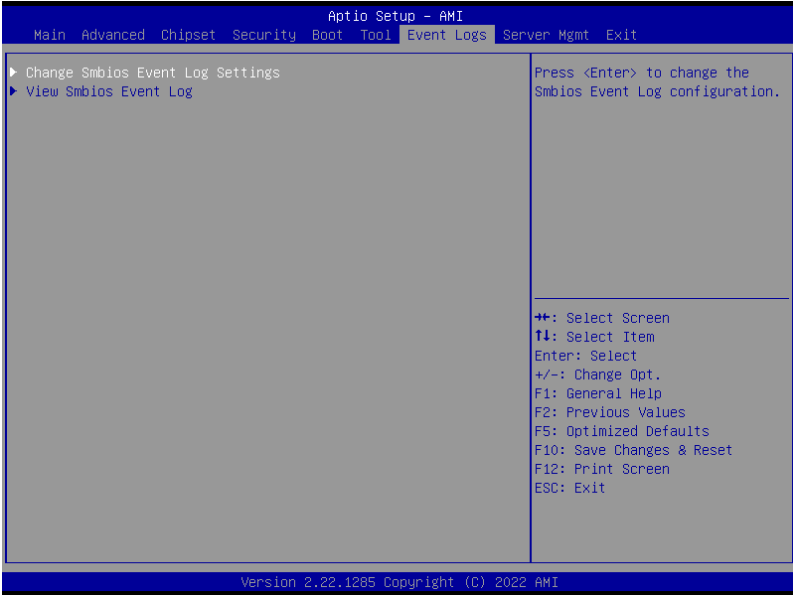

4.10.1 Change Smbios Event Log Settings

Press <Enter> to change the Smbios Event Log configuration.



All values changed here do not take effect until computer is restarted.

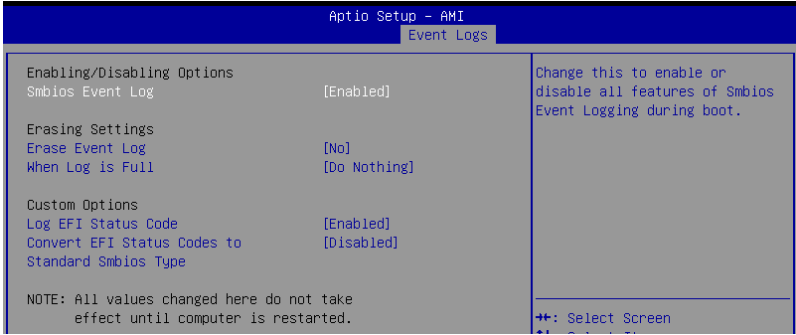

Enabling/Disabling Options

Smbios Event Log [Enabled]

Change this to enable or disable all features of Smbios Event Logging during boot.
Configuration options: [Disabled] [Enabled]



The following item appears only when **Smbios Event Log** is set to **[Enabled]**.

Erasing Settings

Erase Event Log [No]

Choose options for erasing Smbios Event Log. Erasing is done prior to any logging activation during reset.

Configuration options: [No] [Yes, Next reset] [Yes, Every reset]

When Log is Full [Do Nothing]

Choose options for reactions to a full Smbios Event Log.

Configuration options: [Do Nothing] [Erase Immediately]

Custom Options

Log EFI Status Code [Enabled]

Configuration options: [Disabled] [Enabled]



The following item appears only when **Log EFI Status Code** is set to **[Enabled]**.

Convert EFI Status Codes to Standard Smbios Type [Disabled]

Configuration options: [Disabled] [Enabled]

4.10.2 View Smbios Event Log

Press <Enter> to view all smbios event logs.

Aptio Setup - AMI					
Event Logs					
DATE	TIME	ERROR CODE	SEVERITY	COUNT	DESCRIPTION
01/01/11	00:00:01	Smbios 0x16	N/A	N/A	Log Area Reset and Count is applicable only for
09/16/22	10:01:00	EFI 03051002	Major	01	Multi-Events
09/16/22	16:06:55	EFI 03051002	Major	01	

4.11 Server Mgmt menu

The Server Management menu displays the server management status and allows you to change the settings.

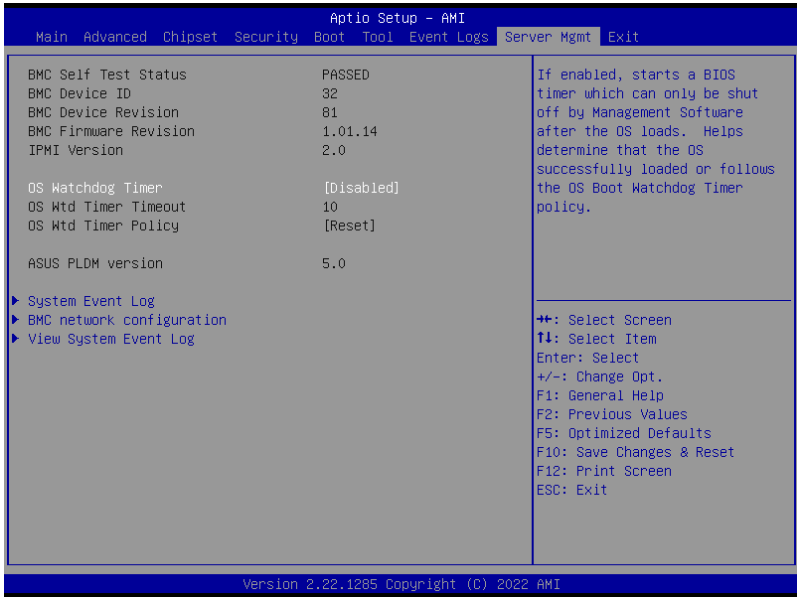

OS Watchdog Timer [Disabled]

Allows you to start a BIOS timer which can only be shut off by Management Software after the OS loads. Helps determine if the OS successfully loaded or follows the OS Boot Watchdog Timer policy.

Configuration options: [Disabled] [Enabled]



The following items appear only when the **OS Watchdog Timer** is set to **[Enabled]**.

OS Wtd Timer Timeout [10]

Allows you to enter a value between 1 to 30 minutes for OS Boot Watchdog Timer Expiration.

Configuration options: [1] - [30]

OS Wtd Timer Policy [Reset]

This item allows you to configure the how the system should respond if the OS Boot Watch Timer expires.

Configuration options: [Do Nothing] [Reset] [Power Down]

4.11.1 System Event Log

Allows you to change the SEL event log configuration.



All values changed here do not take effect until computer is restarted.

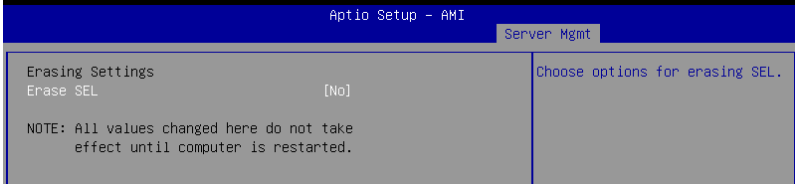

Erase SEL [No]

Allows you to choose options for erasing SEL.

Configuration options: [No] [Yes, On next reset] [Yes, On every reset]

4.11.2 BMC network configuration

The sub-items in this configuration allow you to configure the BMC network parameters.

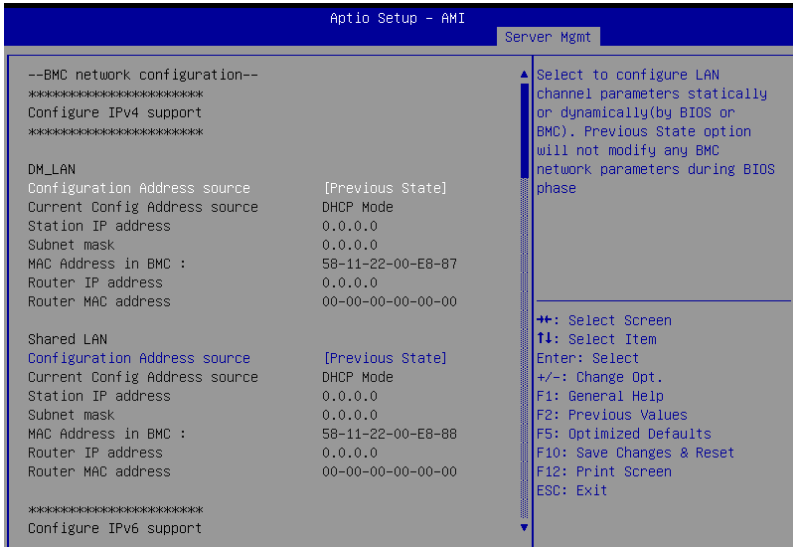

Configure IPV4 support

DM_LAN/Shared LAN

Configuration Address source [Previous State]

This item allows you to configure LAN channel parameters statistically or dynamically (by BIOS or BMC). [Previous State] option will not modify any BMC network parameters during BIOS phase.

Configuration options: [Previous State] [Static] [DynamicBmcDhcp] [DynamicBmcNonDhcp]



The following items are available only when **Configuration Address source** is set to **[Static]**.

Station IP address

Allows you to set the station IP address.

Subnet mask

Allows you to set the subnet mask. We recommend that you use the same Subnet Mask you have specified on the operating system network for the used network card.

Router IP Address

Allows you to set the router IP address.

Router MAC Address

Allows you to set the router MAC address.

Configure IPV6 support

DM_LAN/Shared LAN

IPV6 support [Enabled]

Allows you to enable or disable IPV6 support.

Configuration options: [Enabled] [Disabled]



The following items appear only when **IPV6 support** is set to **[Enabled]**.

Configuration Address source [Previous State]

Allows you to set the LAN channel parameters statically or dynamically (by BIOS or by BMC). **[Previous State]** option will not modify any BMC network parameters during BIOS phase.

Configuration options: [Previous State] [Static] [DynamicBmcDhcp]



The following items are available only when **Configuration Address source** is set to **[Static]**.

Station IPV6 address

Allows you to set the station IPV6 address.

Prefix Length

Allows you to set the prefix length (maximum of Prefix Length is 128).

Configuration Router Lan1-2 Address source [Previous State]

Allows you to set the LAN channel parameters statically or dynamically (by BIOS or by BMC). **[Previous State]** option will not modify any BMC network parameters during BIOS phase.

Configuration options: [Previous State] [Static] [DynamicBmcDhcp]



The following items are available only when **Configuration Router Lan1-2 Address source** is set to **[Static]**.

IPV6 Router1 IP address

Allows you to set the IPV6 Router1 IP address.

IPV6 Router1 Prefix Length Lan1-2

Allows you to set the IPV6 Router1 prefix length (maximum of Prefix Length is 128).

IPV6 Router1 Prefix Value Lan1-2

Allows you to set the IPV6 Router1 prefix value.

4.11.3 View System Event Log

This item allows you to view the system event log records.

The screenshot shows the 'Server Mgmt' menu in the Aptio Setup - AMI utility. The main window is divided into two panes. The left pane displays a list of system event log entries with columns for DATE, TIME, and SENSOR TYPE. The right pane shows hexadecimal data and a legend for function keys.

No. of log entries in SEL : 39

DATE	TIME	SENSOR TYPE
12/31/79	19:00:09	Physical Security
09/02/22	05:53:09	Power Unit
09/02/22	05:55:35	Power Unit
09/02/22	05:55:41	Power Unit
09/02/22	05:57:50	Power Unit
09/02/22	05:59:40	Power Unit
09/02/22	06:01:30	Power Unit
09/02/22	06:03:19	Power Unit
09/02/22	06:05:09	Power Unit
09/02/22	06:06:59	Power Unit
09/02/22	06:08:48	Power Unit
09/02/22	06:10:38	Power Unit
09/02/22	06:11:36	Power Unit
09/02/22	06:11:42	Power Unit
09/02/22	06:13:52	Power Unit
09/02/22	06:16:42	Power Unit
01/01/11	00:00:07	Power Unit
01/01/11	00:00:13	Power Unit
01/01/11	00:02:43	Power Unit
01/01/11	00:04:53	Power Unit
01/01/11	00:07:04	Power Unit

HEX:
01 00 02 B9 5F CE
12 20 00 04 05 FC
6F 00 00 00
Generator ID: BMC - LUN #0
(Channel #0)
Sensor Number: 0xFC OEM
(Unknown)
Event Description: General
Chassis Intrusion, Record
Type-0x02, Assertion Event.

←+: Select Screen
F1: Select Item
Enter: Select
+/-: Change Opt.
F1: General Help
F2: Previous Values
F5: Optimized Defaults
F10: Save Changes & Reset
F12: Print Screen
ESC: Exit

4.12 Exit menu

The Exit menu items allow you to save or discard your changes to the BIOS items.

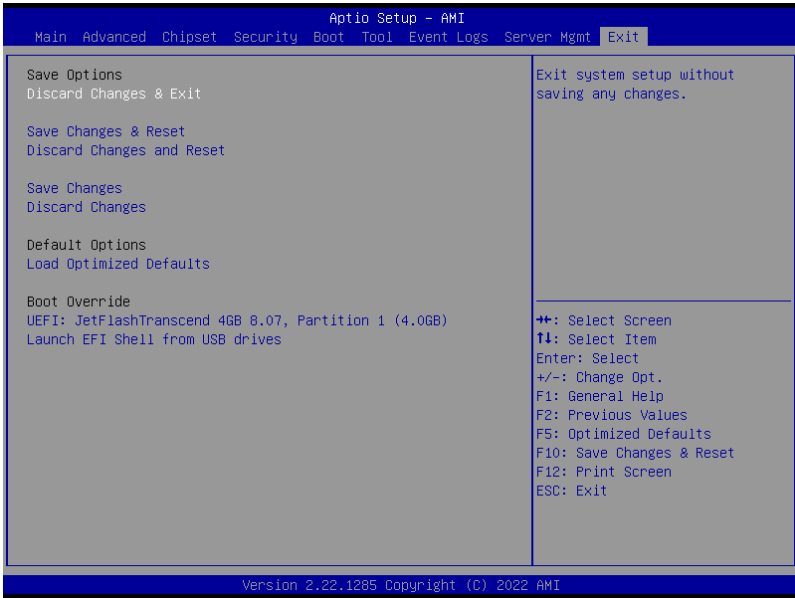

Pressing <Esc> does not immediately exit this menu. Select one of the options from this menu or <F10> from the legend bar to exit.

Save Options

Discard Changes and Exit

Exit system setup without saving any changes.

Save Changes and Reset

Reset system after saving the changes.

Discard Changes and Reset

Reset system setup without saving any changes.

Save Changes

Save changes done so far to any of the setup options.

Discard Changes

Discard changes done so far to any of the setup options.

Default Options

Load Optimized Defaults

Restore/Load Default values for all the setup options.

Boot Override

These items displays the available devices. The device items that appears on the screen depends on the number of devices installed in the system. Click an item to start booting from the selected device.

Launch EFI Shell from filesystem device

Attempt to Launch EFI Shell application (Shell.efi) from one of the available filesystem devices.

Appendix

This appendix includes additional information that you may refer to when configuring the motherboard.

K14PP-D24 block diagram

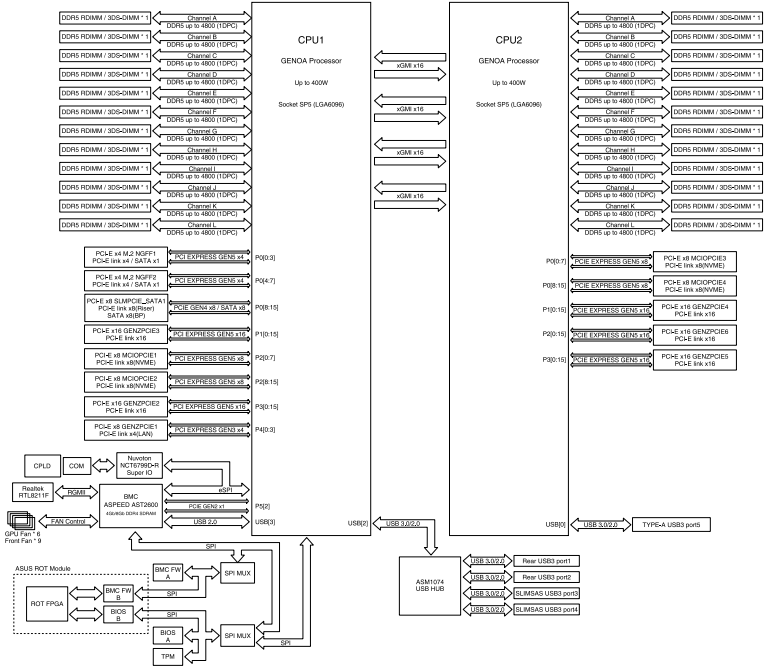

Notices

Federal Communications Commission Statement

This device complies with Part 15 of the FCC Rules. Operation is subject to the following two conditions:

- This device may not cause harmful interference.
- This device must accept any interference received including interference that may cause undesired operation.

This equipment has been tested and found to comply with the limits for a Class A digital device, pursuant to part 15 of the FCC Rules. These limits are designed to provide reasonable protection against harmful interference when the equipment is operated in a commercial environment. This equipment generates, uses, and can radiate radio frequency energy and, if not installed and used in accordance with the instruction manual, may cause harmful interference to radio communications. Operation of this equipment in a residential area is likely to cause harmful interference in which case the user will be required to correct the interference at his own expense.



The use of shielded cables for connection of the monitor to the graphics card is required to assure compliance with FCC regulations. Changes or modifications to this unit not expressly approved by the party responsible for compliance could void the user's authority to operate this equipment.

Compliance Statement of Innovation, Science and Economic Development Canada (ISED)

This device complies with Innovation, Science and Economic Development Canada licence exempt RSS standard(s). Operation is subject to the following two conditions: (1) this device may not cause interference, and (2) this device must accept any interference, including interference that may cause undesired operation of the device.

CAN ICES-003(B)/NMB-003(B)

Déclaration de conformité de Innovation, Sciences et Développement économique Canada (ISED)

Le présent appareil est conforme aux CNR d'Innovation, Sciences et Développement économique Canada applicables aux appareils radio exempts de licence. L'exploitation est autorisée aux deux conditions suivantes : (1) l'appareil ne doit pas produire de brouillage, et (2) l'utilisateur de l'appareil doit accepter tout brouillage radioélectrique subi, même si le brouillage est susceptible d'en compromettre le fonctionnement.

CAN ICES-003(B)/NMB-003(B)

Australia statement notice

From 1 January 2012 updated warranties apply to all ASUS products, consistent with the Australian Consumer Law. For the latest product warranty details please visit <https://www.asus.com/support/>. Our goods come with guarantees that cannot be excluded under the Australian Consumer Law. You are entitled to a replacement or refund for a major failure and compensation for any other reasonably foreseeable loss or damage. You are also entitled to have the goods repaired or replaced if the goods fail to be of acceptable quality and the failure does not amount to a major failure.

If you require assistance please call ASUS Customer Service 1300 2787 88 or visit us at <https://www.asus.com/support/>.



DO NOT throw the motherboard in municipal waste. This product has been designed to enable proper reuse of parts and recycling. This symbol of the crossed out wheeled bin indicates that the product (electrical and electronic equipment) should not be placed in municipal waste. Check local regulations for disposal of electronic products.



DO NOT throw the mercury-containing button cell battery in municipal waste. This symbol of the crossed out wheeled bin indicates that the battery should not be placed in municipal waste.

Japan statement notice

This product cannot be directly connected to the Internet (including public wireless LAN) of a telecom carrier (mobile network companies, landline network companies, Internet providers, etc.). When connecting this product to the Internet, be sure to connect it through a router or switch.

インターネット回線への接続に関するご注意

本製品は電気通信事業者（移动通信会社、固定通信会社、インターネットプロバイダ等）の通信回線（公衆無線LANを含む）に直接接続することができません。本製品をインターネットに接続する場合は、必ずルータ等を経由し接続してください。」等が考えられる。

Safety Precautions

Accessories that came with this product have been designed and verified for the use in connection with this product. Never use accessories for other products to prevent the risk of electric shock or fire.

安全上のご注意

付属品は当該専用品です。他の機器には使用しないでください。機器の破損もしくは、火災や感電の原因となることがあります。

Declaration of compliance for product environmental regulation

ASUS follows the green design concept to design and manufacture our products, and makes sure that each stage of the product life cycle of ASUS product is in line with global environmental regulations. In addition, ASUS disclose the relevant information based on regulation requirements.

Please refer to <https://esg.asus.com/Compliance.htm> for information disclosure based on regulation requirements ASUS is complied with:

EU REACH and Article 33

Complying with the REACH (Registration, Evaluation, Authorization, and Restriction of Chemicals) regulatory framework, we publish the chemical substances in our products at ASUS REACH website at <https://esg.asus.com/Compliance.htm>.

EU RoHS

This product complies with the EU RoHS Directive. For more details, see <https://esg.asus.com/Compliance.htm>

Japan JIS-C-0950 Material Declarations

Information on Japan RoHS (JIS-C-0950) chemical disclosures is available on <https://esg.asus.com/Compliance.htm>

India RoHS

This product complies with the "India E-Waste (Management) Rules, 2016" and prohibits use of lead, mercury, hexavalent chromium, polybrominated biphenyls (PBBs) and polybrominated diphenyl ethers (PBDEs) in concentrations exceeding 0.1% by weight in homogenous materials and 0.01% by weight in homogenous materials for cadmium, except for the exemptions listed in Schedule II of the Rule.

Vietnam RoHS

ASUS products sold in Vietnam, on or after September 23, 2011, meet the requirements of the Vietnam Circular 30/2011/TT-BCT.

Các sản phẩm ASUS bán tại Việt Nam, vào ngày 23 tháng 9 năm 2011 trở về sau, đều phải đáp ứng các yêu cầu của Thông tư 30/2011/TT-BCT của Việt Nam.

Türkiye RoHS

AEEE Yönetmeliğine Uygundur

ASUS Recycling/Takeback Services

ASUS recycling and takeback programs come from our commitment to the highest standards for protecting our environment. We believe in providing solutions for you to be able to responsibly recycle our products, batteries, other components as well as the packaging materials. Please go to <https://esg.asus.com/en/Takeback.htm> for detailed recycling information in different regions.

Ecodesign Directive

The European Union announced a framework for the setting of ecodesign requirements for energy-related products (2009/125/EC). Specific implementing measures are aimed at improving environmental performance of specific products or across multiple product types. ASUS provides product information at <https://esg.asus.com/Compliance.htm>.

Access Advance Patent Notice



FCC COMPLIANCE INFORMATION

Per FCC Part 2 Section 2.1077



Responsible Party: **Asus Computer International**
Address: **48720 Kato Rd, Fremont, CA 94538.**
Phone/Fax No: **(510)739-3777/(510)608-4555**

hereby declares that the product

Product Name : **Server**
Model Number : **RS700A-E12-RS12U, RS700A-E12-RS4U**

compliance statement:

This device complies with part 15 of the FCC Rules. Operation is subject to the following two conditions: (1) This device may not cause harmful interference, and (2) this device must accept any interference received, including interference that may cause undesired operation.

Ver. 180620

Simplified UKCA Declaration of Conformity

ASUSTeK Computer Inc. hereby declares that this device is in compliance with the essential requirements and other relevant provisions of related UKCA Directives. Full text of UKCA declaration of conformity is available at: www.asus.com/support

Simplified EU Declaration of Conformity

English ASUSTeK Computer Inc. hereby declares that this device is in compliance with the essential requirements and other relevant provisions of related Directives. Full text of EU declaration of conformity is available at: www.asus.com/support

Français AsusTek Computer Inc. déclare par la présente que cet appareil est conforme aux critères essentiels et autres clauses pertinentes des directives concernées. La déclaration de conformité de l'UE peut être téléchargée à partir du site Internet suivant : www.asus.com/support

Deutsch ASUSTeK Computer Inc. erklärt hiermit, dass dieses Gerät mit den wesentlichen Anforderungen und anderen relevanten Bestimmungen der zugehörigen Richtlinien übereinstimmt. Der gesamte Text der EU-Konformitätserklärung ist verfügbar unter: www.asus.com/support

Italiano ASUSTeK Computer Inc. con la presente dichiara che questo dispositivo è conforme ai requisiti essenziali e alle altre disposizioni pertinenti con le direttive correlate. Il testo completo della dichiarazione di conformità UE è disponibile all'indirizzo: www.asus.com/support

Русский Компания ASUS заявляет, что это устройство соответствует основным требованиям и другим соответствующим условиям соответствующих директив. Подробную информацию, пожалуйста, смотрите на www.asus.com/support

Български С настоящото ASUSTeK Computer Inc. декларира, че това устройство е в съответствие със съществените изисквания и другите приложими постановления на свързаните директиви. Пълният текст на декларацията за съответствие на ЕС е достъпна на адрес: www.asus.com/support

Hrvatski ASUSTeK Computer Inc. ovim izjavljuje da je ovaj uređaj sukladan s bitnim zahtjevima i ostalim odgovarajućim odredbama vezanih direktiva. Cijeli tekst EU izjave o sukladnosti dostupan je na: www.asus.com/support

Čeština Společnost ASUSTeK Computer Inc. tímto prohlašuje, že toto zařízení splňuje základní požadavky a další příslušná ustanovení souvisejících směrnic. Plné znění prohlášení o shodě EU je k dispozici na adrese: www.asus.com/support

Dansk ASUSTeK Computer Inc. erklærer hermed, at denne enhed er i overensstemmelse med hovedkravene og andre relevante bestemmelser i de relaterede direktiver. Hele EU-overensstemmelseserklæringen kan findes på: www.asus.com/support

Nederlands ASUSTeK Computer Inc. verklaart hierbij dat dit apparaat voldoet aan de essentiële vereisten en andere relevante bepalingen van de verwante richtlijnen. De volledige tekst van de EU-verklaring van conformiteit is beschikbaar op: www.asus.com/support

Eesti Käesolevaga kinnitab ASUSTeK Computer Inc, et see seade vastab asjakohaste direktiivide oluliste nõuetele ja teistele asjassepuutuvatele sätetele. EL vastavusdeklaratsiooni täielik tekst on saadaval järgmisel aadressil: www.asus.com/support

Suomi ASUSTeK Computer Inc. ilmoittaa täten, että tämä laite on asiaankuuluvien direktiivien olennaisten vaatimusten ja muiden tätä koskevien säädösten mukainen. EU-yhdenmukaisuusilmoituksen koko teksti on luettavissa osoitteessa: www.asus.com/support

Ελληνικά Με το παρόν, η AsusTek Computer Inc. δηλώνει ότι αυτή η συσκευή συμμορφώνεται με τις θεμελιώδεις απαιτήσεις και άλλες σχετικές διατάξεις των Οδηγιών της ΕΕ. Το πλήρες κείμενο της δήλωσης συμβατότητας είναι διαθέσιμο στη διεύθυνση: www.asus.com/support

Magyar Az ASUSTeK Computer Inc. ezennel kijelenti, hogy ez az eszköz megfelel a kapcsolódó irányelvek lényeges követelményeinek és egyéb vonatkozó rendelkezéseinek. Az EU megfeleléségi nyilatkozat teljes szövege innen letölthető: www.asus.com/support

Latviski ASUSTeK Computer Inc. ar šo paziņo, ka šī ierīce atbilst saistīto Direktīvu būtiskajām prasībām un citiem citiem saistošajiem nosacījumiem. Pilns ES atbilstības paziņojuma teksts pieejams šeit: www.asus.com/support

Lietuvių „ASUSTeK Computer Inc.“ šiuo tvirtina, kad šis įrenginys atitinka pagrindinius reikalavimus ir kitas svarbias susijusių direktyvų nuostatas. Visą ES atitikties deklaracijos tekstą galima rasti: www.asus.com/support

Norsk ASUSTeK Computer Inc. erklærer herved at denne enheten er i samsvar med hovedsaklige krav og andre relevante forskrifter i relaterte direktiver. Fullstendig tekst for EU-samsvarserklæringen finnes på: www.asus.com/support

Polski Firma ASUSTeK Computer Inc. niniejszym oświadcza, że urządzenie to jest zgodne z zasadniczymi wymogami i innymi właściwymi postanowieniami powiązanych dyrektyw. Pełny tekst deklaracji zgodności UE jest dostępny pod adresem: www.asus.com/support

Português A ASUSTeK Computer Inc. declara que este dispositivo está em conformidade com os requisitos essenciais e outras disposições relevantes das Diretivas relacionadas. Texto integral da declaração da UE disponível em: www.asus.com/support

Română ASUSTeK Computer Inc. declară că acest dispozitiv se conformează cerințelor esențiale și altor prevederi relevante ale directivelor conexe. Textul complet al declarației de conformitate a Uniunii Europene se găsește la: www.asus.com/support

Srpski ASUSTeK Computer Inc. ovim izjavljuje da je ovaj uređaj u saglasnosti sa osnovnim zahtevima i drugim relevantnim odredbama povezanih Direktiva. Pun tekst EU deklaracije o usaglašenosti je dostupan da adresi: www.asus.com/support

Slovensky Spoločnosť ASUSTeK Computer Inc. týmto vyhlasuje, že toto zariadenie vyhovuje základným požiadavkám a ostatým príslušným ustanoveniam príslušných smerníc. Celý text vyhlásenia o zhode pre štáty EÚ je dostupný na adrese: www.asus.com/support

Slovenščina ASUSTeK Computer Inc. izjavlja, da je ta naprava skladna z bistvenimi zahtevami in drugimi ustreznimi določbami povezanih direktiv. Celotno besedilo EU-izjave o skladnosti je na voljo na spletnem mestu: www.asus.com/support

Español Por la presente, ASUSTeK Computer Inc. declara que este dispositivo cumple los requisitos básicos y otras disposiciones pertinentes de las directivas relacionadas. El texto completo de la declaración de la UE de conformidad está disponible en: www.asus.com/support

Svenska ASUSTeK Computer Inc. förklarar härmed att denna enhet överensstämmer med de grundläggande kraven och andra relevanta föreskrifter i relaterade direktiv. Fulltext av EU-försäkran om överensstämmelse finns på: www.asus.com/support

Українська ASUSTeK Computer Inc. заявляє, що цей пристрій відповідає основним вимогам та іншим відповідним положенням відповідних Директив. Повний текст декларації відповідності стандартам ЄС доступний на: www.asus.com/support

Türkçe AsusTek Computer Inc., bu aygıtın temel gereksinimlerle ve ilişkili Yönergelerin diğer ilgili koşullarıyla uyumlu olduğunu beyan eder. AB uygunluk bildiriminin tam metni şu adreste bulunabilir: www.asus.com/support

Bosanski ASUSTeK Computer Inc. ovim izjavljuje da je ovaj uređaj usklađen sa bitnim zahtjevima i ostalim odgovarajućim odredbama vezanih direktiva. Cijeli tekst EU izjave o usklađenosti dostupan je na: www.asus.com/support

Service and Support

Visit our multi-language website at <https://www.asus.com/support/>

