



SuperServer®
SYS-622B-TRT

USER'S MANUAL

Revision 1.0a MNL-2771

The information in this User's Manual has been carefully reviewed and is believed to be accurate. The vendor assumes no responsibility for any inaccuracies that may be contained in this document, and makes no commitment to update or to keep current the information in this manual, or to notify any person or organization of the updates. Note: For the most up-to-date version of this manual, see our website at <https://www.supermicro.com>.

Super Micro Computer, Inc. ("Supermicro") reserves the right to make changes to the product described in this manual at any time and without notice. This product, including software and documentation, is the property of Supermicro and/or its licensors, and is supplied only under a license. Any use or reproduction of this product is not allowed, except as expressly permitted by the terms of said license.

IN NO EVENT WILL Super Micro Computer, Inc. BE LIABLE FOR DIRECT, INDIRECT, SPECIAL, INCIDENTAL, SPECULATIVE OR CONSEQUENTIAL DAMAGES ARISING FROM THE USE OR INABILITY TO USE THIS PRODUCT OR DOCUMENTATION, EVEN IF ADVISED OF THE POSSIBILITY OF SUCH DAMAGES. IN PARTICULAR, SUPER MICRO COMPUTER, INC. SHALL NOT HAVE LIABILITY FOR ANY HARDWARE, SOFTWARE, OR DATA STORED OR USED WITH THE PRODUCT, INCLUDING THE COSTS OF REPAIRING, REPLACING, INTEGRATING, INSTALLING OR RECOVERING SUCH HARDWARE, SOFTWARE, OR DATA.

Any disputes arising between manufacturer and customer shall be governed by the laws of Santa Clara County in the State of California, USA. The State of California, County of Santa Clara shall be the exclusive venue for the resolution of any such disputes. Supermicro's total liability for all claims will not exceed the price paid for the hardware product.

FCC Statement: This equipment has been tested and found to comply with the limits for a Class A or Class B digital device pursuant to Part 15 of the FCC Rules. These limits are designed to provide reasonable protection against harmful interference when the equipment is operated in industrial environment for Class A device or in residential environment for Class B device. This equipment generates, uses, and can radiate radio frequency energy and, if not installed and used in accordance with the manufacturer's instruction manual, may cause harmful interference with radio communications. Operation of this equipment in a residential area is likely to cause harmful interference, in which case you will be required to correct the interference at your own expense.

California Best Management Practices Regulations for Perchlorate Materials: This Perchlorate warning applies only to products containing CR (Manganese Dioxide) Lithium coin cells. "Perchlorate Material-special handling may apply. See <https://www.dtsc.ca.gov/hazardouswaste/perchlorate>".



WARNING: This product can expose you to chemicals including lead, known to the State of California to cause cancer and birth defects or other reproductive harm. For more information, go to <https://www.P65Warnings.ca.gov>.



AVERTISSEMENT : Ce produit peut vous exposer à des agents chimiques, y compris le plomb, identifié par l'État de Californie comme pouvant causer le cancer, des malformations congénitales ou d'autres troubles de la reproduction. Pour de plus amples informations, prière de consulter <https://www.P65Warnings.ca.gov>.

The products sold by Supermicro are not intended for and will not be used in life support systems, medical equipment, nuclear facilities or systems, aircraft, aircraft devices, aircraft/emergency communication devices or other critical systems whose failure to perform be reasonably expected to result in significant injury or loss of life or catastrophic property damage. Accordingly, Supermicro disclaims any and all liability, and should buyer use or sell such products for use in such ultra-hazardous applications, it does so entirely at its own risk. Furthermore, buyer agrees to fully indemnify, defend and hold Supermicro harmless for and against any and all claims, demands, actions, litigation, and proceedings of any kind arising out of or related to such ultra-hazardous use or sale.

Manual Revision 1.0a

Release Date: July 24, 2025

Unless you request and receive written permission from Super Micro Computer, Inc., you may not copy any part of this document. Information in this document is subject to change without notice. Other products and companies referred to herein are trademarks or registered trademarks of their respective companies or mark holders.

Copyright © 2025 by Super Micro Computer, Inc.
All rights reserved.

Published in the United States of America

Preface

About This Manual

This manual is written for professional system integrators and PC technicians. It provides information for the installation and use of the SYS-622B-TRT server. Installation and maintenance should be performed by certified service technicians only.

Notes

For your system to work properly, follow the links below to download all necessary drivers/utilities and the user's manual for your server.

- Supermicro product manuals: <https://www.supermicro.com/support/manuals>
- Product drivers and utilities: <https://www.supermicro.com/wdl>
- Product safety info: https://www.supermicro.com/about/policies/safety_information.cfm
- A secure data deletion tool designed to fully erase all data from storage devices can be found on our website:
https://www.supermicro.com/about/policies/disclaimer.cfm?url=/wdl/utility/Lot9_Secure_Data_Deletion_Utility
- Frequently Asked Questions: <https://www.supermicro.com/FAQ/index.php>
- If you still have questions after referring to our FAQs, contact our support team. Region-specific Technical Support email addresses can be found at: "[Contacting Supermicro](#)" on page 11
- If you have any feedback on Supermicro product manuals, contact our writing team at: Techwriterteam@supermicro.com

This manual may be periodically updated without notice. Check the Supermicro website for possible updates to the manual revision level.

Conventions Used in the Manual

Special attention should be given to the following symbols for proper installation and to prevent damage done to the components or injury to yourself.



Warning! Indicates important information given to prevent equipment/property damage or personal injury.



Warning! Indicates high voltage may be encountered while performing a procedure.

Important: Important information given to ensure proper system installation or to relay safety precautions.

Note: Additional information given to differentiate various models or to provide information for proper system setup.

Contents

Contacting Supermicro	11
Chapter 1: Introduction	12
1.1 Overview	13
1.2 System Features	15
Front View	15
Drive Carriers	16
Control Panel	17
Rear View	19
1.3 System Architecture	21
Main Components	21
Motherboard Block Diagram	22
1.4 Motherboard Quick Reference	23
Motherboard Layout	23
Quick Reference	26
Chapter 2: Server Installation	28
2.1 Unpacking the System	29
2.2 Preparing for Setup	30
Choosing a Setup Location	30
Rack Precautions	30
System Precautions	30
Rack Mounting Considerations	31
Ambient Operating Temperature	32
Airflow	32
Mechanical Loading	32
Circuit Overloading	32
Reliable Ground	32
2.3 Installing the Rails	33
Identifying the Rails	33
Releasing the Inner Rail	34
Installing Inner Rails onto the Chassis	35
Installing the Outer Rails onto the Rack	36

2.4 Installing the Chassis into the Rack	37
Removing the Chassis from the Rack	39
Chapter 3: Maintenance and Component Installation	40
3.1 Removing Power	42
3.2 Accessing the System	43
Removing the Chassis Cover	43
3.3 Static-Sensitive Devices	44
Precautions	44
3.4 Processor and Heatsink Installation	45
LGA 4710 Socket E2 Processors	46
Processor Top View	46
Overview of the Processor Carrier	47
Processor Carriers	47
Overview of the Processor Socket	49
Overview of the Processor Heatsink Module	50
Installing the Processor	52
Assembling the Processor Heatsink Module	55
Preparing the Processor Socket for Installation	57
Preparing to Install the PHM into the Processor Socket	58
Installing the Processor Heatsink Module	60
Removing the Processor Heatsink Module	62
3.5 Memory Support and Installation	65
General Guidelines for Optimizing Memory Performance	65
Memory Support	65
DIMM Installation	71
DIMM Removal	73
3.6 Motherboard Battery Removal and Installation	74
Battery Removal	74
Proper Battery Disposal	74
Battery Installation	74
3.7 Storage Drives	75
Hot-Swap for NVMe Drives	75
Ejecting a Drive	75
Replacing a Drive	76

3.8 System Cooling	77
Fans	77
Changing a System Fan	77
Air Shrouds	78
Installing an Air Shroud	78
3.9 Expansion Cards	79
PCIe Cards	79
Installing Expansion Cards	79
3.10 Power Supply	81
Replacing the Power Supply	81
Chapter 4: Motherboard Connections, Jumpers, and LEDs	83
4.1 Power Supply and Power Connections	85
ATX Power Connectors	85
4.2 Headers and Connections	86
Backplane SMBus Header	86
Chassis Intrusion	86
COM Header	86
External BMC I ² C Header	87
Fan Headers	87
M.2 M-Key PCIe 5.0 x4 Slots	88
MCIO PCIe 5.0 x8 Connectors	88
NC-SI Connection	88
NVMe SMBus Header	88
Power SMB (I ² C) Header	89
SATA Ports	89
Standby Power	90
TPM/Port 80 Header	90
USB Header	91
VGA Header	91
VROC RAID Key Header	91
4.3 Front Control Panel Header	93
Power On and BMC/BIOS Status LED Button	93
Reset Button	94
Power Fail LED	94

Overheat/Fan Fail and UID LED	95
NIC1/NIC2 (LAN1/LAN2)	95
HDD LED/UID Switch	96
Power LED	96
NMI Button	97
4.4 Rear I/O Ports	98
COM Port	98
LAN Ports (LAN1, LAN2, and BMC LAN)	99
USB Ports	99
VGA Port	99
Unit Identifier/BMC Reset Switch	99
4.5 Jumper Settings	101
CMOS Clear	101
LAN Ports Enable/Disable	102
4.6 LED Indicators	103
BMC Heartbeat LED	103
BMC LAN LEDs	103
LAN LEDs	103
M.2 LEDs	104
Onboard Power LED	104
Unit ID (UID) LED	104
Chapter 5: Software	105
5.1 Microsoft Windows OS Installation	106
Installing the OS	106
5.2 Driver Installation	108
5.3 BMC	110
BMC ADMIN User Password	110
Chapter 6: Optional Components	111
6.1 TPM Security Module	112
6.2 HBA Card	113
6.3 RAID Cards	114
6.4 Cable Management Arm	115
Installing the Cable Management Arm	116
Removing the Cable Management Arm	117

6.5 Intel Virtual RAID on CPU (VROC)	118
Requirements and Restrictions	118
Additional Information	118
Hardware Key	119
Configuring Intel VMD	120
Configuring VMD Manually	120
Creating NVMe RAID Configurations	125
Status Indications	126
Hot-Swap Drives	127
Hot-Unplug	127
Hot-Plug	127
Related Information Links	127
Chapter 7: Troubleshooting and Support	128
7.1 Online Resources	129
Direct Links for the SYS-622B-TRT System	129
Direct Links for General Support and Information	129
7.2 Baseboard Management Controller (BMC)	130
7.3 Troubleshooting Procedures	131
Before Power On	131
No Power	131
No Video	131
System Boot Failure	131
Memory Errors	132
Losing the System's Setup Configuration	132
If the System Becomes Unstable	132
7.4 CMOS Clear	134
7.5 Motherboard Battery	135
7.6 Where to Get Replacement Components	136
7.7 Technical Support Procedures	137
Returning Merchandise for Service	137
7.8 Feedback	139
Chapter 8: UEFI BIOS	140
8.1 Introduction	141
Updating BIOS	141

Starting the Setup Utility	141
8.2 Main Setup	143
8.3 Advanced Setup Configurations	145
8.4 Event Logs	146
8.5 BMC	147
8.6 Security	148
8.7 Boot	150
8.8 Save & Exit	152
Appendix A: BIOS Codes	154
BIOS Error POST (Beep) Codes	154
Additional BIOS POST Codes	154
Appendix B: Standardized Warning Statements for AC Systems	155
Warning Definition	155
Installation Instructions	157
Circuit Breaker	158
Power Disconnection Warning	160
Equipment Installation	161
Restricted Area	163
Battery Handling	164
Redundant Power Supplies	166
Backplane Voltage	167
Comply with Local and National Electrical Codes	169
Product Disposal	170
Fan Warning	171
Power Cable and AC Adapter	173
Appendix C: System Specifications	177
Appendix C: RoHS Certification	181

Contacting Supermicro

Headquarters

Address: Super Micro Computer, Inc.
980 Rock Ave.
San Jose, CA 95131 U.S.A.

Tel: +1 (408) 503-8000

Fax: +1 (408) 503-8008

Email: Marketing@supermicro.com (General Information)
Sales-USA@supermicro.com (Sales Inquiries)
Government_Sales-USA@supermicro.com (Gov. Sales Inquiries)
Support@supermicro.com (Technical Support)
RMA@Supermicro.com (RMA Support)
Webmaster@supermicro.com (Webmaster)

Website: <https://www.supermicro.com>

Europe

Address: Super Micro Computer B.V.
Het Sterrenbeeld 28, 5215 ML
's-Hertogenbosch, The Netherlands

Tel: +31 (0) 73-6400390

Fax: +31 (0) 73-6416525

Email: Sales_Europe@supermicro.com (Sales Inquiries)
Support_Europe@supermicro.com (Technical Support)
RMA_Europe@supermicro.com (RMA Support)

Website: <https://www.supermicro.nl>

Asia-Pacific

Address: Super Micro Computer, Inc.
3F, No. 150, Jian 1st Rd.
Zhonghe Dist., New Taipei City 235 Taiwan (R.O.C)

Tel: +886 (2) 8226-3990

Fax: +886 (2) 8226-3992

Email: Sales-Asia@supermicro.com.tw (Sales Inquiries)
Support@supermicro.com.tw (Technical Support)
RMA@supermicro.com.tw (RMA Support)

Website: <https://www.supermicro.com.tw>

Chapter 1:

Introduction

This chapter provides a brief outline of the functions and features of the SYS-622B-TRT system. It is based on the X14DBI-T motherboard and the CSE-825BTS-R1K23LPP1 chassis.

1.1 Overview	13
1.2 System Features	15
Front View	15
Rear View	19
1.3 System Architecture	21
Main Components	21
Motherboard Block Diagram	22
1.4 Motherboard Quick Reference	23
Motherboard Layout	23
Quick Reference	26

1.1 Overview

This chapter provides a brief outline of the functions and features of the SYS-622B-TRT. The following provides an overview of the specifications and capabilities.

System Overview	
Motherboard	X14DBI-T
Chassis	CSE-825BTS-R1K23LPP1
Processor	Supports dual Intel® Xeon® 6700-series processors with E-cores with a thermal design power (TDP) up to 330 W
Memory	16 DIMM slots that support up to 2 TB of RDIMM DDR5 memory with speeds of up to 6400 MHz
Drive Support	Default: total eight bays Four front hot-swap 3.5" NVMe*/SAS*/SATA drive bays Four front hot-swap 3.5" SAS*/SATA drive bays Two M.2 PCIe 5.0 x4 NVMe slots (M-key) One slim DVD bay (optional) *NVMe/SAS support may require additional storage controller and/or cables
Expansion Slots	Four PCIe 5.0 x16 slots (low profile) Two PCIe 5.0 x8 slots (low profile)
I/O Ports	Two RJ45 10GBASE-T ports One dedicated management LAN port (BMC LAN) One VGA port (rear) Four rear USB 3.0 ports Two front USB 3.0 ports One TPM 2.0 header Two COM ports (one rear, one front)
System Cooling	Three heavy-duty fans with optimal fan speed control One air shroud
Power	Two 1200 W high-efficiency Titanium Level digital power supplies Optional: 1050 W DC power module
Form Factor	2U rackmount; (WxHxD) 17.2" x 3.5" x 25.5" (336 x 76 x 40 mm)

Notes:

- A Quick Reference Guide can be found on the following page of the Supermicro website: <https://www.supermicro.com/en/products/system/mainstream/2u/sys-622b-trt>
- The following safety models associated with the SYS-622B-TRT have been certified as compliant with UL or CSA: 825-R12X14, 825-12, 825-R11DX14, 825-11D

1.2 System Features

The following views of the system display the main features. Refer to the System Specifications appendix of this manual for additional specifications.

Front View

The following features are located on the front of the SYS-622B-TRT server.

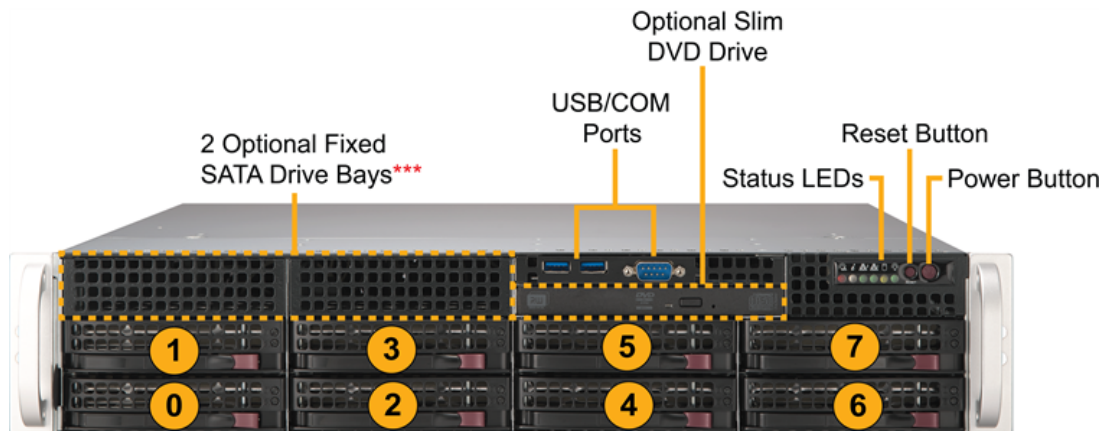

***Fixed SATA drives require additional parts from the optional parts list

Figure 1-1. Front View

Chassis Features: Front	
Feature	Description
2 Optional Fixed SATA Drive Bays	Two optional fixed SATA drive bays Fixed SATA drives require additional parts from the optional parts list
USB/COM Ports	Two USB 3.0 ports and one COM port
Optional Slim DVD Drive	One optional slim DVD drive
Status LEDs	Six status LEDs providing information about the drive and its components See " Control Panel " on page 17 for more information
Reset Button	One reset button
Power Button	One power button

Storage Drive Locations	
Location	Description
0–3	3.5" hot-swap NVMe**/SAS/SATA3 drive bays
4–7	3.5" hot-swap SAS*/SATA3 drive bays

Storage Drive Locations	
Location	Description
*SAS3 drive support requires additional parts from the optional parts list.	
**NVMe drive support requires additional parts from the optional parts list.	

Drive Carriers

Each drive carrier has two LED indicators: an activity indicator and a status indicator. For RAID configurations using a controller, the meaning of the status indicator is described in the table below. For OS RAID or non-RAID configurations, some LED indications are not supported, such as hot spare.

Drive Carrier LED Indicators			
	Color	Blinking Pattern	Behavior for Device
Activity LED	Blue	Solid On	SAS/NVMe drive installed
	Blue	Blinking	I/O Activity
Status LED	Red	Solid On	Failure of drive with VROC support
	Red	Blinking at 1 Hz	Rebuild drive with VROC support
	Red	Blinking with two blinks and one stop at 1 Hz	Hot spare for drive with VROC support
	Red	On for five seconds, then off	Power on for drive with VROC support
	Red	Blinking at 4 Hz	Identify drive with VROC support
	Green	Solid On	Save to remove in NVMe device (not supported in VMD mode)
	Amber	Blinking at 1 Hz	Attention state; do not remove NVMe device (not supported in VMD mode)

Note: Enterprise level drives are recommended for use in Supermicro chassis and servers.

Control Panel

The SYS-622B-TRT features a control panel on the upper-right of the front of the server.

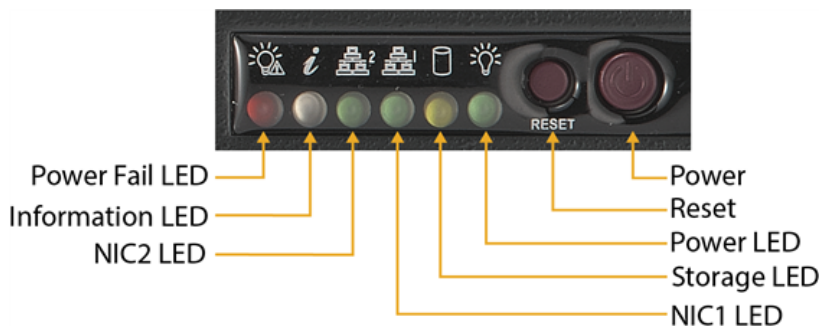

Figure 1-2. Front Control Panel

Control Panel Features	
Feature	Description
Power Fail LED	Indicates a power failure in the power supply when flashing
Information LED	Alerts operator to several states, as noted in Information LED table
NIC1/NIC2 LED	Indicates network activity on LANs when flashing
Storage LED	Indicates activity on the storage drives when flashing.
Power LED	Steady on: Power on Blinking at 4 Hz: Checking BIOS/BMC integrity Blinking at 4 Hz and "i" LED is blue: BIOS firmware updating Two blinks at 4 Hz, one pause 2 Hz, and "i" LED blue: BMC firmware updating Blinking at 1 Hz and "i" LED red: Fault detected
Reset	Reboot the system
Power Button	Applies or removes primary power from the power supply to the server and maintains standby power Hold for four seconds to force a shut-down

Information LED	
Color, Status	Description
Red, solid	An overheat condition has occurred.
Red, blinking at 1 Hz	Fan failure; check for an inoperative fan.
Red, blinking at 0.25 Hz	Power failure; check for an inoperative power supply.

Information LED	
Color, Status	Description
Red, solid with Power LED blinking green	Fault detected.
Blue and red, blinking at 10 Hz	Recovery mode.
Blue, solid	UID has been activated locally to locate the server in a rack environment.
Blue, blinking at 1 Hz	UID has been activated via BMC to locate the server in a rack environment.
Blue, blinking at 2 Hz	BMC is resetting.
Blue, blinking at 4 Hz	BMC is setting factory defaults.
Blue, blinking at 10 Hz with Power LED blinking green	BMC/BIOS firmware is updating.

Rear View

The following features are located on the rear of the SYS-622B-TRT server.

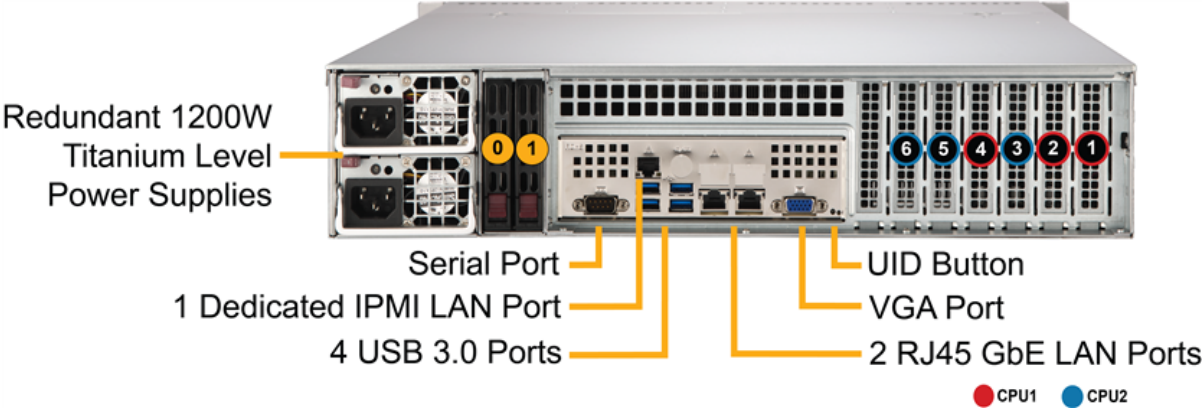

Figure 1-3. Rear View

Drive Carrier LED Indicators	
Feature	Description
Power Supplies	Redundant 1200 W Titanium Level power supplies
LAN Ports	One dedicated IPMI LAN port Two RJ45 GbE LAN ports
USB Ports	Four USB 3.0 ports
UID button	One UID button
VGA Port	One video port

Drive Bay Locations	
Location	Description
0-1	Optional 2.5" hot-swap NVMe/SAS/SATA3 drive bay

Expansion Slot Locations	
Location	Description
1	One PCIe 5.0 x8 LP slot (CPU1)
2, 4	One PCIe 5.0 x16 LP slot (CPU1)
3, 5	One PCIe 5.0 x16 LP slot (CPU2)
6	One PCIe 5.0 x8 LP slot (CPU2)

Power Supply Indicators		
Power Supply Condition	Green LED	Amber LED
No AC Power to Power Supply	Off	Off
Power Supply critical events causing a shutdown/ failure/ OCP/ OVP/ Fan Fail/ OTP/ UVP	Off	On
Power Supply Warning Events Where the power supply continues to operate; high temperature; over voltage; under voltage, etc.	Off	1 Hz Blinking
AC present only 12 VSB ON (PS OFF)	1 Hz Blinking	Off
Output ON and OK	On	Off
AC cord unplugged and in redundant mode	Off	On

1.3 System Architecture

This section covers the locations of the system's main components and provides a system block diagram.

Main Components

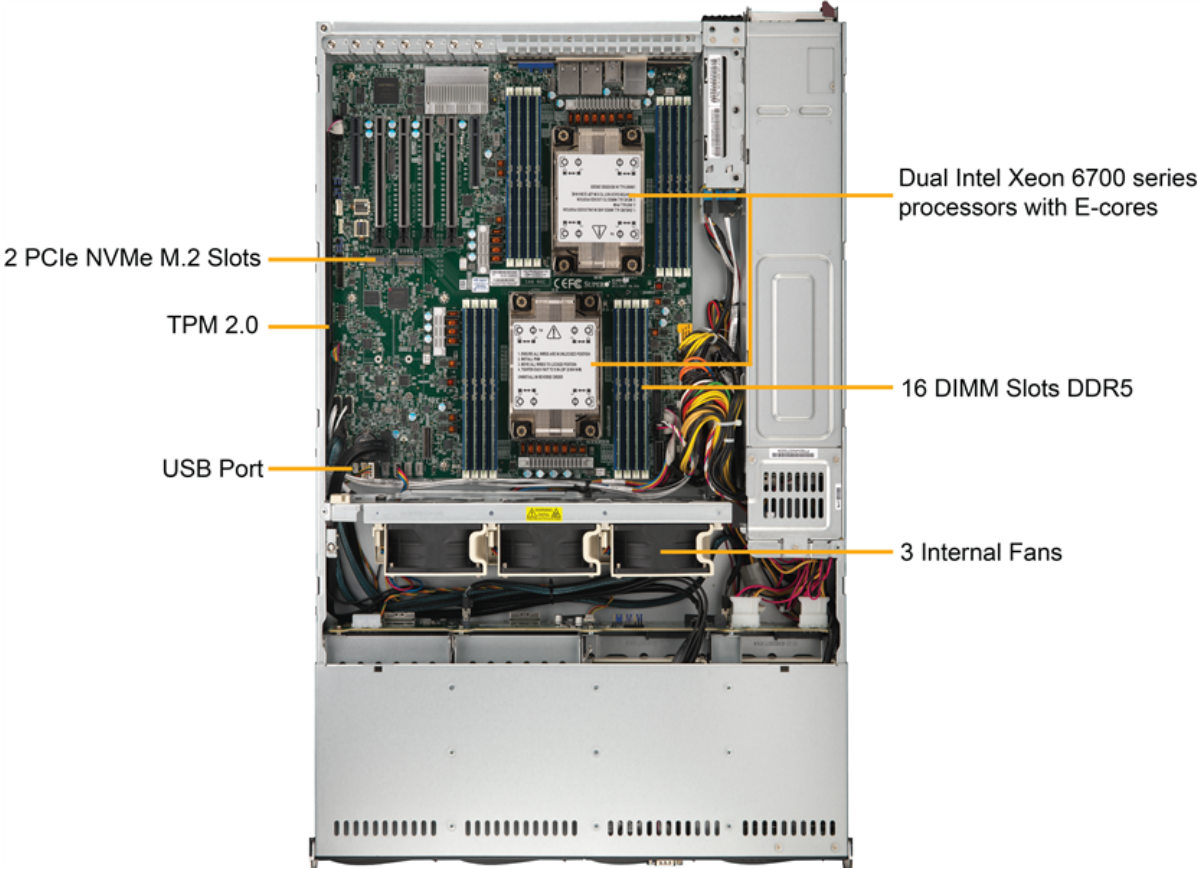

Figure 1-4. SYS-622B-TRT Main Component Locations

System Features: Top	
Feature	Description
PCIe NVMe Slots	Two PCIe NVMe M.2 slots
TPM 2.0	One TPM 2.0 module
USB Port	One USB port
Processors	Dual Intel® Xeon® 6700-series processors with E-cores
DIMM Slots	16 DDR5 DIMM slots
System Fans	Three internal fans

Motherboard Block Diagram

X14DBI/X14DBI-T

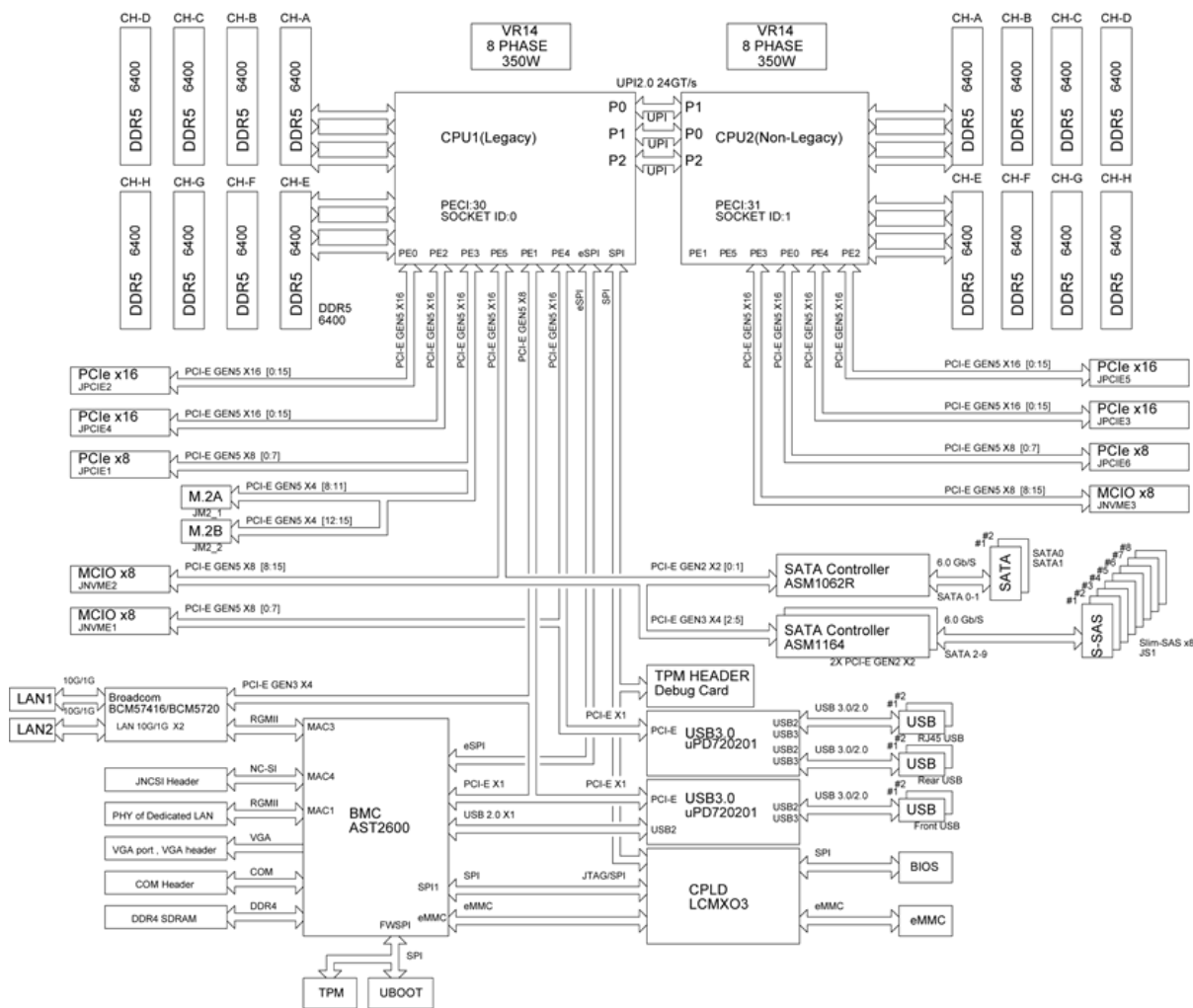

Figure 1-5. Motherboard Block Diagram

Note: This is a general **block** diagram and may not exactly represent the features on your motherboard. See the previous pages for the actual specifications of your motherboard.

1.4 Motherboard Quick Reference

For details on the X14DBI-T motherboard layout and other quick reference information, refer to the content below.

Motherboard Layout

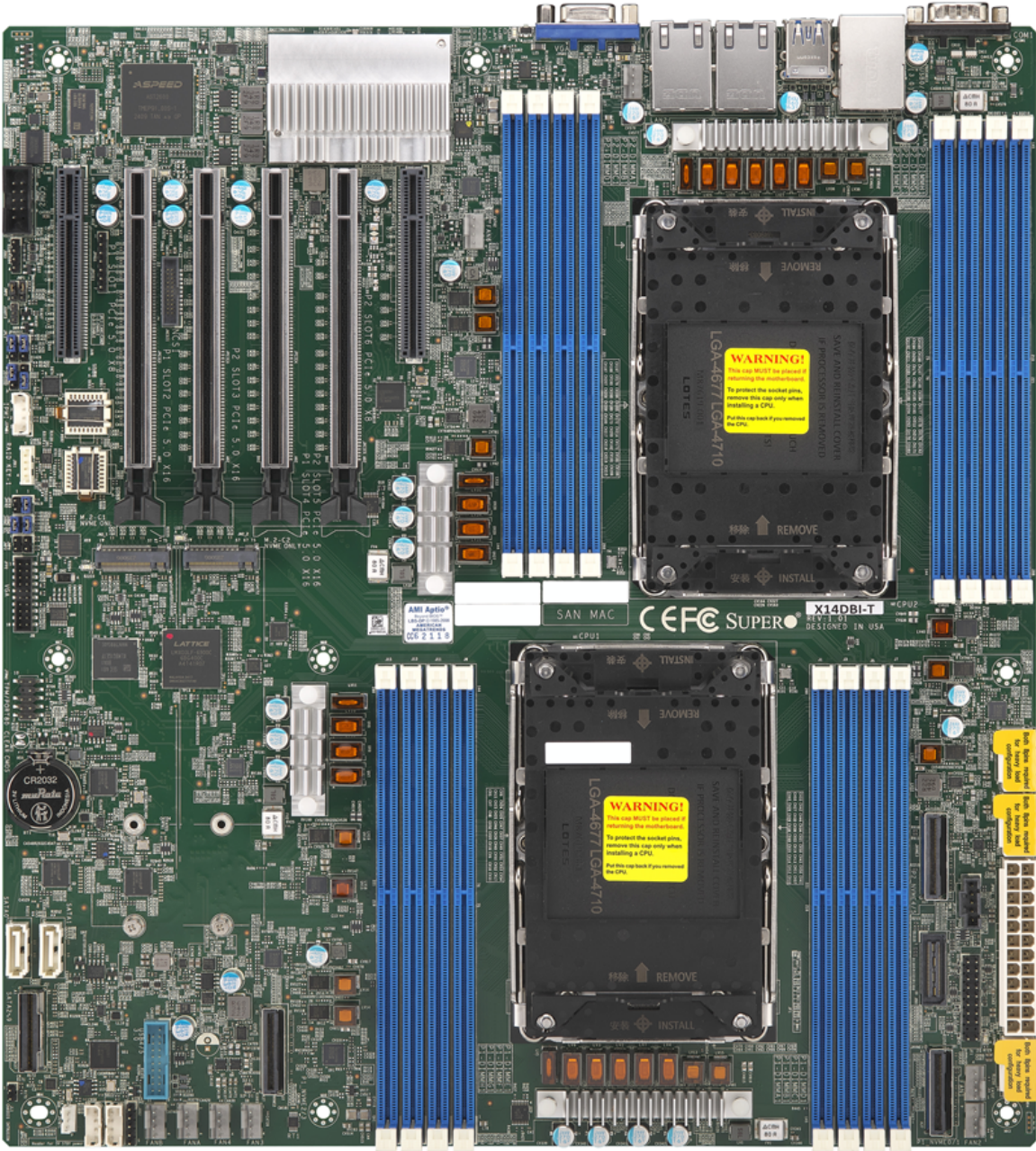

Figure 1-6. X14DBI-T Motherboard Image

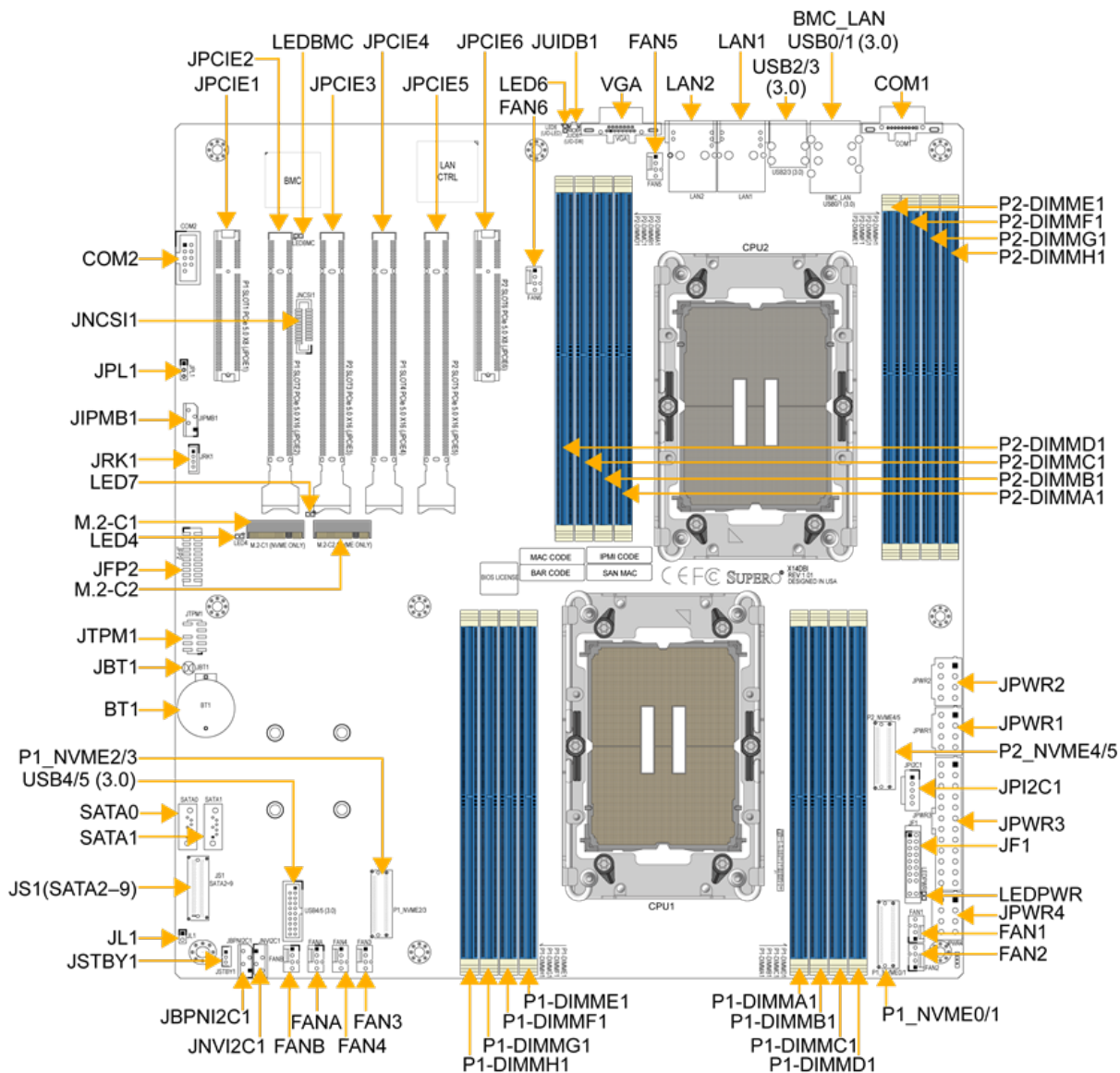

Figure 1-7. X14DBI-T Motherboard Layout

Differences between and X14DBI-T		
		X14DBI-T
LAN1 and LAN2	1 GbE	10 GbE
LAN controller	Broadcom 5720	Broadcom 57416

Notes:

- For detailed information on jumpers, connectors, and LED indicators, see ["Maintenance and Component Installation" on page 40.](#)
- "■" indicates the location of pin 1.
- Components not documented are for internal testing purposes only.
- Use only the correct type of onboard CMOS battery as specified by the manufacturer. To avoid possible explosion, do not install the onboard battery upside down.

Quick Reference

Jumper	Description	Default Setting
JBT1	Clear CMOS (Onboard)	Open (Normal)
JPL1	LAN1, LAN2 Enable/Disable	Pins 1-2 (Enabled)

LED	Description	Status
LED4, LED7	M.2 LEDs (for M.2-C1, M.2-C2)	Blinking Green: Device Working
LED6	Unit Identifier (UID) LED	Solid Blue: Unit Identified
LEDBMC	BMC Heartbeat LED	Blinking Green: BMC Normal (Active), Solid Green: During BMC Reset or during a Cold Reboot
LEDPWR	Onboard Power LED	Solid Green: Power On

Connector	Description
BT1	Onboard CMOS Battery
BMC_LAN	Dedicated BMC LAN Port
COM1	Rear COM Port
COM2	Front Accessible COM Port Header
FAN1–FAN6, FANA, FANB	CPU/System Fan Headers
JBPNI2C1	Backplane SMBus Header
JF1	Front Control Panel Header
JFP2	Front Accessible VGA Connection Header
JIPMB1	4-pin BMC External I ² C Header (for Inlet Temperature Sensor)
JL1	Chassis Intrusion Header
JNCSI1	NC-SI (Network Controller Sideband Interface) Connector
JNVI2C1	NVMe SMBus I ² C Header with hot-plug support

Connector	Description
JPCIE1 (SLOT1), JPCIE6 (SLOT6)	PCIe 5.0 x8 Slots (SLOT1: supported by CPU1, SLOT6: supported by CPU2)
JPCIE2 (SLOT2), JPCIE4 (SLOT4)	PCIe 5.0 x16 Slots supported by CPU1
JPCIE3 (SLOT3), JPCIE5 (SLOT5)	PCIe 5.0 x16 Slots supported by CPU2
JPI2C1	Power System Management Bus (SMBus) I ² C Header
JPWR1, JPWR2, JPWR4	8-pin Power Connectors
JPWR3	24-pin ATX Power Connector
JRK1	Intel VROC Key Header for NVMe RAID support
JS1 (SATA2–9)	SlimSAS x8 Connector with support of eight SATA 3.0 connections
JSTBY1	5 V Standby Power Header
JTPM1	Trusted Platform Module/Port 80 Header
JUIDB1	Unit Identifier (UID) Switch / BMC Reset Button
LAN1, LAN2	10 GbE LAN Ports
M.2-C1, M.2-C2	PCIe 5.0 x4 NVMe M.2 Slots supported by CPU1 (with support of M-Key 2280 and 22110 form factors)
P1_NVME0/1, P1_ NVME2/3	MCIO PCIe 5.0 x8 Connectors supported by CPU1, each with support of two NVMe connections
P2_NVME4/5	MCIO PCIe 5.0 x8 connector supported by CPU2, with support of two NVMe connections
SATA0, SATA1	SATA 3.0 Ports with support of RAID 0/1
USB0/1 (3.0)	Rear USB 3.0 Ports (5 Gbps, Type-A)
USB2/3 (3.0)	Rear USB 3.0 Ports (5 Gbps, Type-A)
USB4/5 (3.0)	USB 3.0 Header with support of two USB connections
VGA	Rear VGA Port

Note: Jumpers, connectors, switches, and LED indicators that are not described in these tables are for manufacturing testing purposes only, and are not covered in this manual.

Chapter 2:

Server Installation

This chapter provides advice and instructions for mounting your server in a server rack. If your server is not already fully integrated with processors, system memory, etc., refer to ["Maintenance and Component Installation" on page 40](#) for details on installing those specific components.

Important: Electrostatic Discharge (ESD) can damage electronic components. To prevent such damage to printed circuit boards (PCBs), it is important to use a grounded wrist strap, handle all PCBs by their edges, and keep PCBs in anti-static bags when not in use.

2.1 Unpacking the System	29
2.2 Preparing for Setup	30
Choosing a Setup Location	30
Rack Precautions	30
System Precautions	30
Rack Mounting Considerations	31
2.3 Installing the Rails	33
Identifying the Rails	33
Releasing the Inner Rail	34
Installing Inner Rails onto the Chassis	35
Installing the Outer Rails onto the Rack	36
2.4 Installing the Chassis into the Rack	37
Removing the Chassis from the Rack	39

2.1 Unpacking the System

Inspect the box the SYS-622B-TRT server was shipped in and note if it was damaged in any way. If any equipment appears damaged, file a damage claim with the carrier who delivered it.

Decide on a suitable location for the rack unit that will hold the server. It should be situated in a clean, dust-free area that is well ventilated. Avoid areas where heat, electrical noise and electromagnetic fields are generated. It will also require a grounded AC power outlet nearby. Be sure to read the precautions and considerations noted in ["Standardized Warning Statements for AC Systems"](#) on page 155.

2.2 Preparing for Setup

The box in which the SYS-622B-TRT server was shipped should include the rackmount hardware needed to install it into the rack. Read this section in its entirety before you begin the installation.

Choosing a Setup Location

- The server should be situated in a clean, dust-free area that is well ventilated. Avoid areas where heat, electrical noise and electromagnetic fields are generated.
- Leave enough clearance in front of the rack so that you can open the front door completely (~25 inches) and approximately 30 inches of clearance in the back of the rack to allow sufficient space for airflow and access when servicing.
- This product should be installed only in a Restricted Access Location (dedicated equipment rooms, service closets, etc.).
- This product is not suitable for use with visual display workplace devices according to §2 of the German Ordinance for Work with Visual Display Units.

Rack Precautions

- Ensure that the leveling jacks on the bottom of the rack are extended to the floor so that the full weight of the rack rests on them.
- In single rack installations, stabilizers should be attached to the rack. In multiple rack installations, the racks should be coupled together.
- Always make sure the rack is stable before extending a server or other component from the rack.
- You should extend only one server or component at a time. Extending two or more simultaneously may cause the rack to become unstable.

System Precautions

- Review the electrical and general safety precautions in "[Standardized Warning Statements for AC Systems](#)" on page 155.
- Determine the placement of each component in the rack before you install the rails.
- Install the heaviest server components at the bottom of the rack first and then work your way up.

- Use a regulating uninterruptible power supply (UPS) to protect the server from power surges and voltage spikes and to keep your system operating in case of a power failure.
- Allow any drives and power supply modules to cool before touching them.
- When not servicing, always keep the front door of the rack and all covers/panels on the servers closed to maintain proper cooling.

Rack Mounting Considerations



Warning! Stability hazard. The rack may tip over causing serious personal injury. Before extending the rack to the installation position, read the installation instructions. Do not put any load on the slide-rail mounted equipment in the installation position. Do not leave the slide-rail mounted equipment in the installation position.



Avertissement!

Danger d'instabilité. Le rack peut basculer et provoquer des blessures corporelles graves.

Avant d'étendre le rack en position d'installation, lire les instructions d'installation. Ne pas charger l'équipement monté sur rail de glissière en position d'installation. Ne pas laisser l'équipement monté sur rail de glissière en position d'installation.

Important: To prevent bodily injury when mounting or servicing this unit in a rack, you must take special precautions to ensure that the system remains stable. The following guidelines are provided to ensure your safety:

- If this unit is the only unit in the rack, it should be mounted at the bottom of the rack.
- When mounting this unit in a partially filled rack, load the rack from the bottom to the top, placing the heaviest component at the bottom of the rack.
- If the rack is provided with stabilizing devices, install the stabilizers before mounting or servicing the unit in the rack.
- Slide rail mounted equipment is not to be used as a shelf or a workspace.
- Do not pick up the server with the front handles. They are designed to pull the system from a rack only.

Ambient Operating Temperature

If installed in a closed or multi-unit rack assembly, the ambient operating temperature of the rack environment may be greater than the room's ambient temperature. Therefore, consideration should be given to installing the equipment in an environment compatible with the manufacturer's maximum rated ambient temperature (TMRA).

Airflow

Equipment should be mounted into a rack so that the amount of airflow required for safe operation is not compromised.

Mechanical Loading

Equipment should be mounted into a rack so that a hazardous condition does not arise due to uneven mechanical loading.

Circuit Overloading

Consideration should be given to the connection of the equipment to the power supply circuitry and the effect that any possible overloading of circuits might have on overcurrent protection and power supply wiring. Appropriate consideration of equipment nameplate ratings should be used when addressing this concern.

Reliable Ground

A reliable ground must be maintained at all times. To ensure this, the rack itself should be grounded. Particular attention should be given to power supply connections other than the direct connections to the branch circuit (i.e. the use of power strips, etc.).

2.3 Installing the Rails

This section provides information on installing the CSE-825BTS-R1K23LPP1 chassis into a rack unit with the rails provided. There are a variety of rack units on the market, which may mean that the assembly procedure will differ slightly from the instructions provided. You should also refer to the installation instructions that came with the rack unit you are using.

Note: This rail will fit a rack between 25.6" and 33" deep.

Identifying the Rails

The SYS-622B-TRT server package includes two rail assemblies. Each assembly consists of three sections: an outer rail, a middle rail, and an inner rail that adjusts in length and secures to the rear post of the rack. These assemblies are specifically designed for the left and right side of the chassis and labeled.

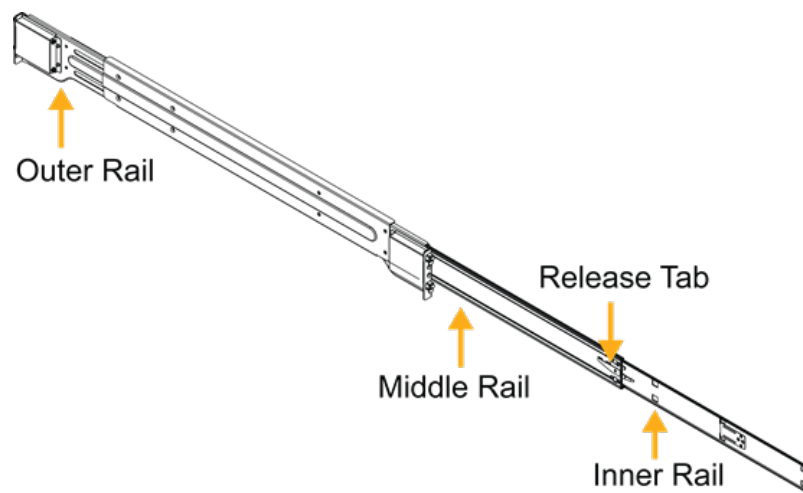

Figure 2-1. Rackmount Rail (Right Rail Assembly Shown)

Releasing the Inner Rail

Each inner rail has a locking latch. This latch prevents the CSE-825BTS-R1K23LPP1 chassis from coming completely out of the rack when the chassis is pulled out for servicing.

To mount the rail onto the chassis, first release the inner rail from the outer rails.

1. Pull the inner rail out of the outer rail until it is fully extended as illustrated below.
2. Press the locking tab down to release the inner rail.
3. Pull the inner rail all the way out.

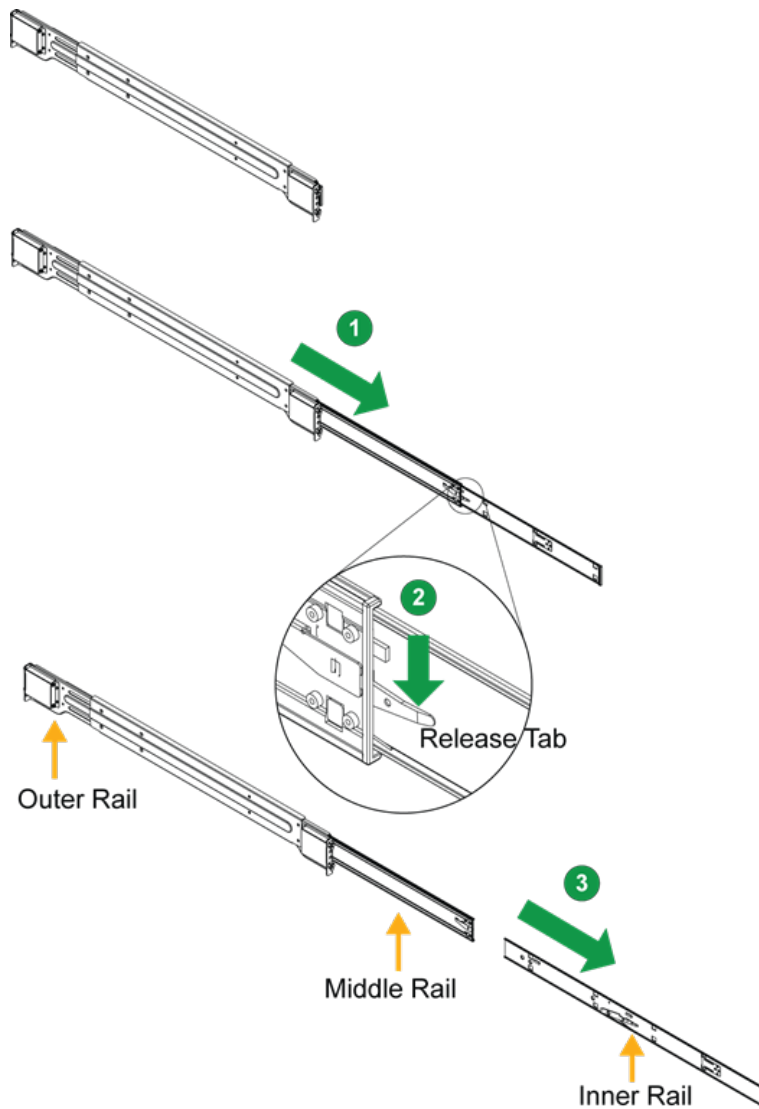

Figure 2-2. Extending and Releasing the Inner Rail

Installing Inner Rails onto the Chassis

Important: Do not pick up the server with the front handles. They are designed to pull the system from a rack only.

Begin the rack mounting procedure by installing the inner rails to the CSE-825BTS-R1K23LPP1 chassis.

1. Confirm that the left and right inner rails have been correctly identified.
2. Place the inner rail firmly against the side of the chassis, aligning the pins on the side of the chassis with the holes in the inner rail.
3. Slide the inner rail toward the rear of the chassis until the pins are at the end of the narrow slot, which secures the inner rail to the chassis.
4. Optionally, you can further secure the inner rail to the chassis with a screw.
5. Repeat for the other inner rail.

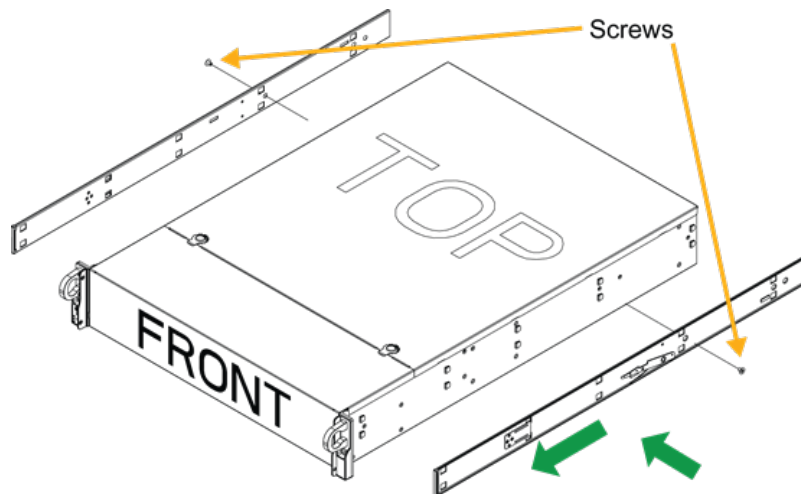

Figure 2-3. Installing the Inner Rails

Installing the Outer Rails onto the Rack

Each end of the assembled outer rail includes a bracket with hooks and square, spring-loaded pegs to fit into the square holes in your rack.

Important: Stability hazard. The rack stabilizing mechanism must be in place, or the rack must be bolted to the floor before you slide the unit out for servicing. Failure to stabilize the rack can cause the rack to tip over.

Important: Do not pick up the server with the front handles. They are designed to pull the system from a rack only.

1. Confirm that the left and right outer rails have been correctly identified.
2. Press upward on the locking tab at the rear end of the middle rail.
3. Push the middle rail back into the outer rail.
4. Hang the hooks on the front of the outer rail onto the square holes on the front of the rack. If desired, use screws to secure the outer rails to the rack.
5. Pull out the rear of the outer rail, adjusting the length until it just fits within the posts of the rack.
6. Hang the hooks of the rear section of the outer rail onto the square holes on the rear of the rack. Take care that the proper holes are used so the rails are level. If desired, use screws to secure the rear of the outer rail to the rear of the rack.
7. Repeat for the other outer rail.

Important: This figure is for illustrative purposes only. Always install servers to the bottom of a rack first.

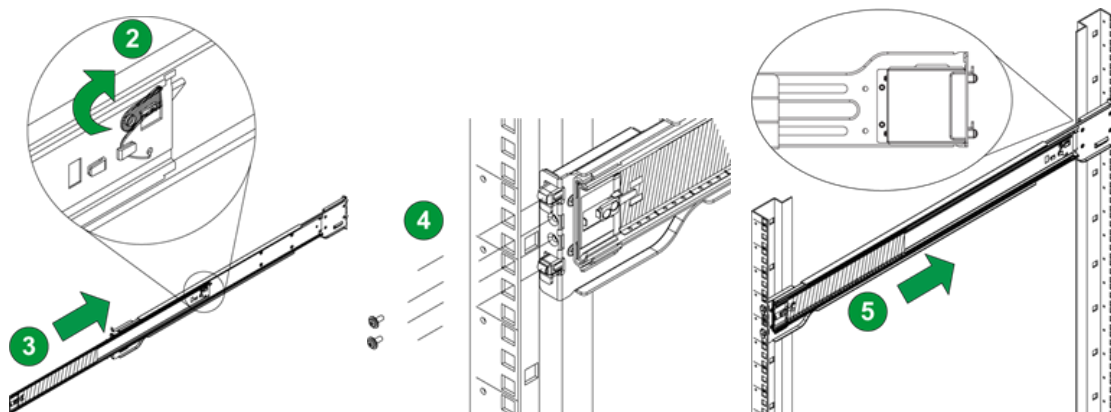

Figure 2-4. Extending and Mounting the Outer Rails

2.4 Installing the Chassis into the Rack

Once rails are attached to the SYS-622B-TRT server and the rack, you can install the server.

Important: Use caution when mounting or removing the system from the rack. For large systems, at least one other person must assist during installation or removal. Follow the safety recommendations printed on the rails. Depending on the size of the system, you might need to use a lift.

1. Extend the outer rails as illustrated below.
2. Align the inner rails of the chassis with the outer rails on the rack.
3. Slide the inner rails into the outer rails, keeping the pressure even on both sides. When the chassis has been pushed completely into the rack, it should click into the locked position.
4. Optional screws may be used to secure the front of the chassis to the rack.

Important: This figure is for illustrative purposes only. Always install servers to the bottom of a rack first.

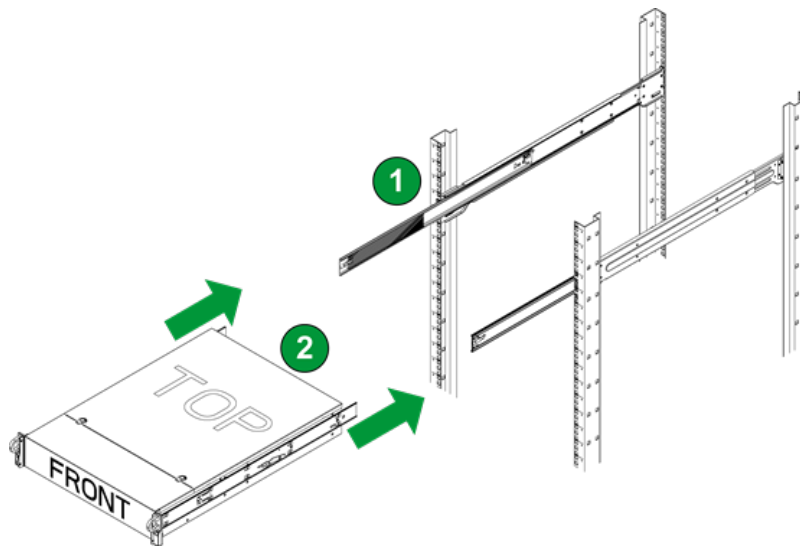

Figure 2-5. Aligning the Chassis with the Rack

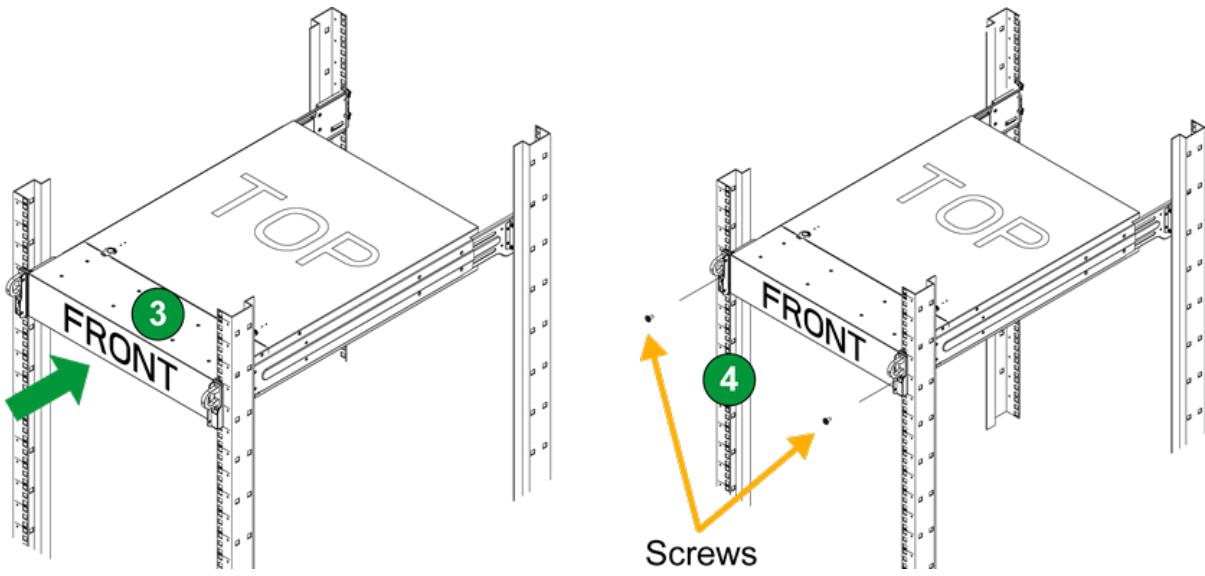

Figure 2-6. Sliding and Securing the Chassis in the Rack

Removing the Chassis from the Rack

Important: Stability hazard. The rack stabilizing mechanism must be in place, or the rack must be bolted to the floor before you slide the unit out for servicing. Failure to stabilize the rack can cause the rack to tip over.

Important: Use caution when mounting or removing the system from the rack. For large systems, at least one other person must assist during installation or removal. Follow the safety recommendations printed on the rails. Depending on the size of the system, you might need to use a lift.

1. If necessary, loosen the thumb screws on the front of the chassis that hold it in the rack.
2. Pull the chassis forward out the front of the rack until it stops.
3. Press the release latches on each of the inner rails downward simultaneously and continue to pull the chassis forward and out of the rack.

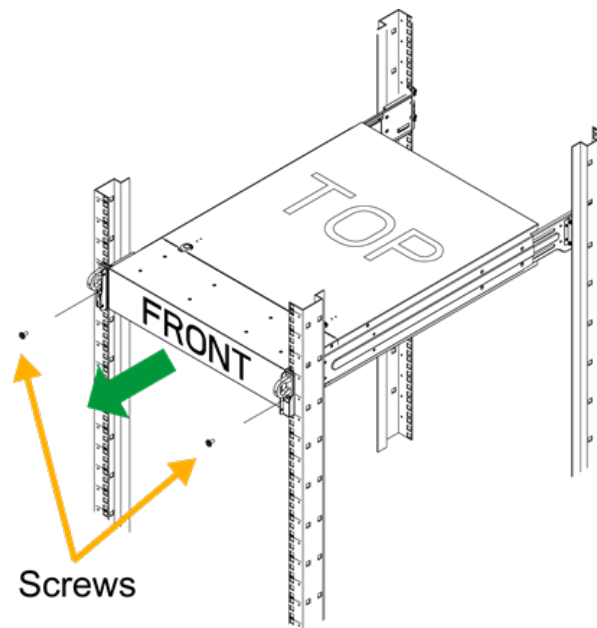

Figure 2-7. Removing the Chassis From the Rack

Chapter 3:

Maintenance and Component Installation

This chapter provides instructions on installing and replacing main system components for the SYS-622B-TRT server. To prevent compatibility issues, only use components that match the specifications and/or part numbers given.

Installation or replacement of most components require that power first be removed from the system. Follow the procedures given in each section.

3.1 Removing Power	42
3.2 Accessing the System	43
Removing the Chassis Cover	43
3.3 Static-Sensitive Devices	44
Precautions	44
3.4 Processor and Heatsink Installation	45
LGA 4710 Socket E2 Processors	46
Overview of the Processor Carrier	47
Overview of the Processor Socket	49
Overview of the Processor Heatsink Module	50
Installing the Processor	52
Assembling the Processor Heatsink Module	55
Preparing the Processor Socket for Installation	57
Preparing to Install the PHM into the Processor Socket	58
Installing the Processor Heatsink Module	60
Removing the Processor Heatsink Module	62
3.5 Memory Support and Installation	65
General Guidelines for Optimizing Memory Performance	65
Memory Support	65
DIMM Installation	71
DIMM Removal	73
3.6 Motherboard Battery Removal and Installation	74
Battery Removal	74
Proper Battery Disposal	74

Battery Installation	74
3.7 Storage Drives	75
Hot-Swap for NVMe Drives	75
3.8 System Cooling	77
Fans	77
Air Shrouds	78
3.9 Expansion Cards	79
PCIe Cards	79
3.10 Power Supply	81
Replacing the Power Supply	81

3.1 Removing Power

Before performing some setup or maintenance tasks, use the following procedure to ensure that power has been removed from the SYS-622B-TRT server. This step is necessary when removing or installing non hot-swap components or when replacing a non-redundant power supply.

1. Use the operating system to power down the system.
2. After the system has completely shut-down, disconnect the AC power cord(s) from the power strip or outlet.
3. Disconnect the power cord(s) from the power supply module(s).

3.2 Accessing the System

The SYS-622B-TRT server features a removable top cover, which allows easy access to the inside of the server.

When performing service on components inside the system, remove the system from the rack and place it on a work bench or desk. Do not service with the system extended from the rack.

Removing the Chassis Cover

You can access some chassis components, such as fans, by removing the cover.

Important: Except for short periods of time, do not operate the server without the cover in place. The chassis cover must be in place to allow for proper airflow and to prevent overheating.

1. Remove power from the system.
2. Press the release tabs to remove the cover from the locked position. Press both tabs at the same time.
3. Once the top cover is released from the locked position, slide the cover toward the rear of the chassis.
4. Lift the cover off the chassis.

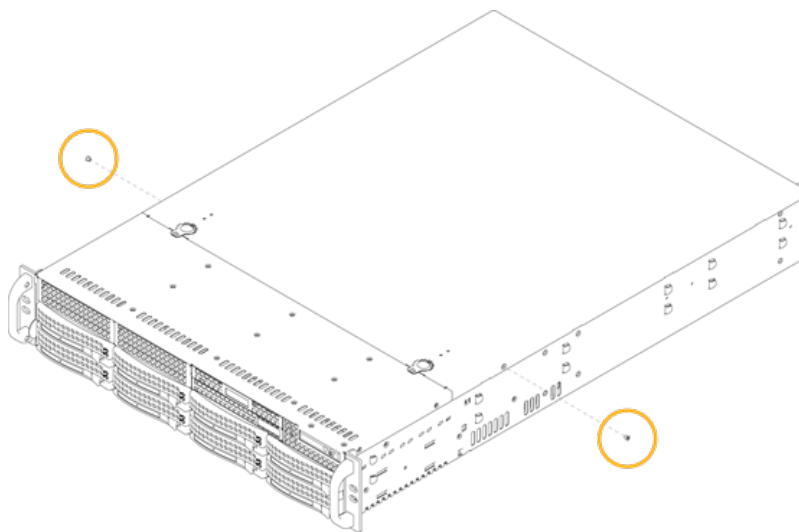

Figure 3-1. Removing the Chassis Cover

3.3 Static-Sensitive Devices

Electrostatic Discharge (ESD) can damage electronic components. To avoid damaging your motherboard, it is important to handle it very carefully. The following measures are generally sufficient to protect your equipment from ESD.

Precautions

- Use a grounded wrist strap designed to prevent static discharge.
- Touch a grounded metal object before removing the board from the antistatic bag.
- Handle the motherboard only by its edges. Do not touch its components, peripheral chips, memory modules, or gold contacts.
- When handling chips or modules, avoid touching their pins.
- Put the motherboard and peripherals back into their antistatic bags when not in use.
- For grounding purposes, make sure that your computer chassis provides excellent conductivity between the power supply, the case, the mounting fasteners, and the motherboard.
- Use only the correct type of onboard CMOS battery. To avoid possible explosion, do not install the onboard battery upside down.

3.4 Processor and Heatsink Installation

This section provides procedures to install the processor(s) and heatsink(s).

Notes:

- Take industry standard precautions to avoid ESD damage. For details, see "[Static-Sensitive Devices](#)" on the previous page.
- Before starting, make sure that the plastic socket cap is in place and none of the socket pins are bent. If any damage is noted, contact your retailer.
- Do not connect the system power cord before the processor and heatsink installation is complete.
- When handling the processor, avoid touching or placing direct pressure on the LGA lands (gold contacts). Improper installation or socket misalignment can cause serious damage to the processor or processor socket.
- When buying a processor separately, use only a Supermicro certified heatsink.
- Refer to the Supermicro website for the most recent processor support.
- When installing the heatsink, ensure a torque driver set to the correct force is used for each screw.
- Thermal grease is pre-applied on a new heatsink. No additional thermal grease is needed.

LGA 4710 Socket E2 Processors

Processor Top View

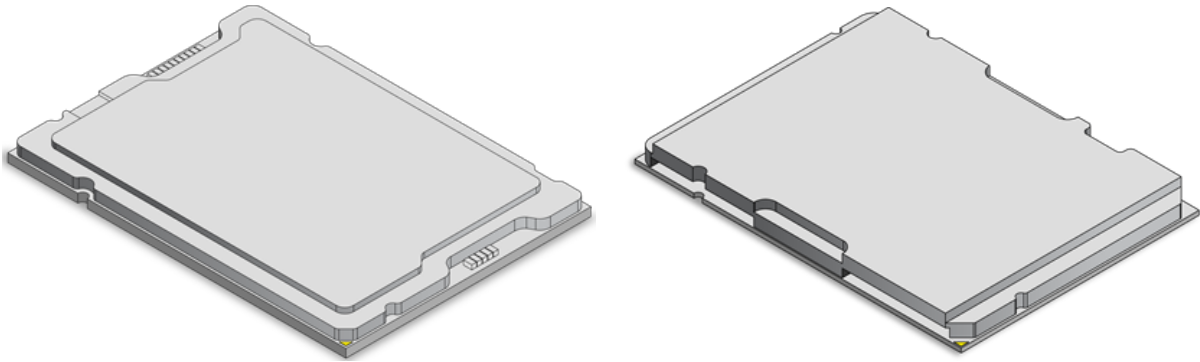

Figure 3-2. Processor (SP XCC left, SP HCC/LCC right)

Note: The motherboard supports three processor SKUs: SP XCC, SP HCC, and SP LCC. Each SKU supports a specific carrier; the SP XCC processor supports Carrier E2A while SP HCC and SP LCC support Carrier E2B. Make sure the processors of the same SKU are on the motherboard.

Overview of the Processor Carrier

The motherboard supports two types of processors and their associated processor carrier.

Processor Carriers

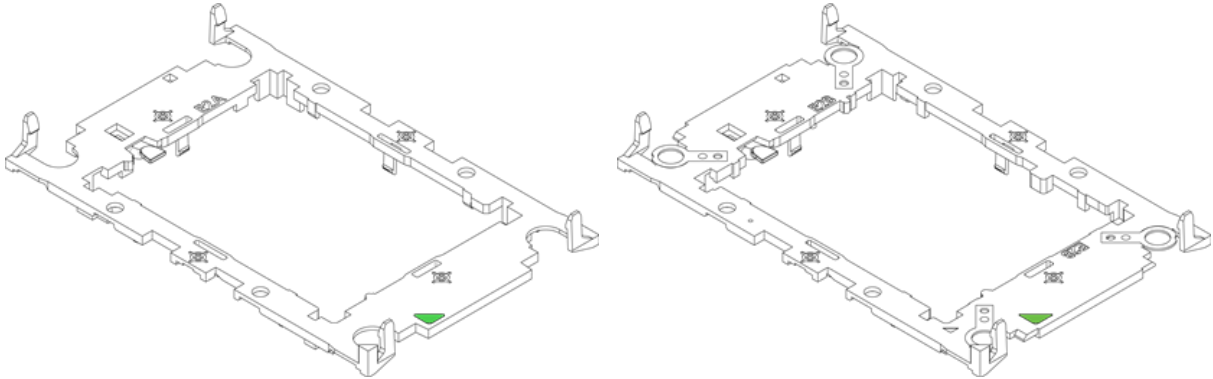

Figure 3-3. Carrier (SP XCC E2A left, SP HCC/LCC E2B right)

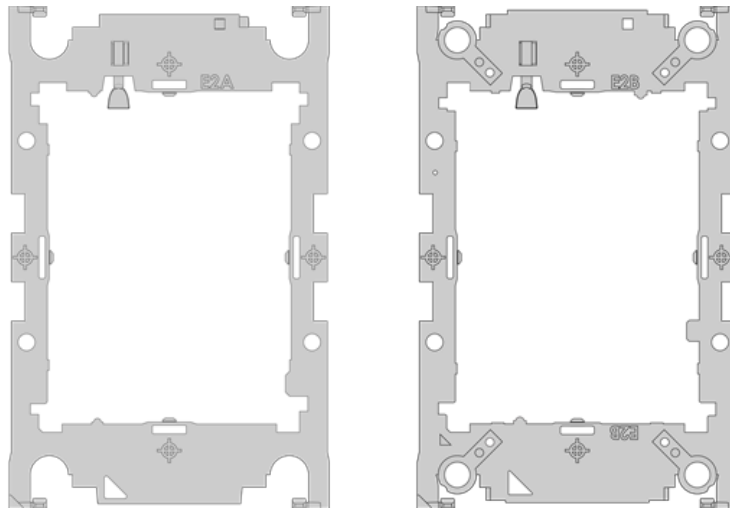

Figure 3-4. Carrier Top View (SP XCC E2A left, SP HCC/LCC E2B right)

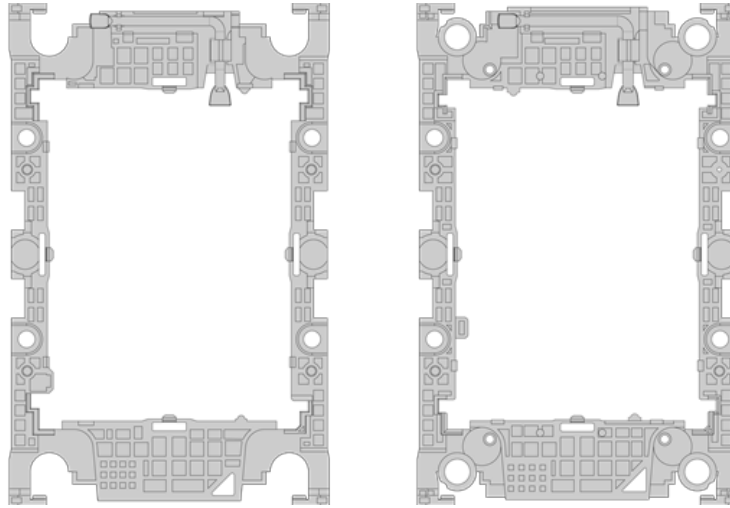

Figure 3-5. Carrier Bottom View (SP XCC E2A left, SP HCC/LCC E2B right)

Overview of the Processor Socket

The processor socket is protected by a plastic protective cover.

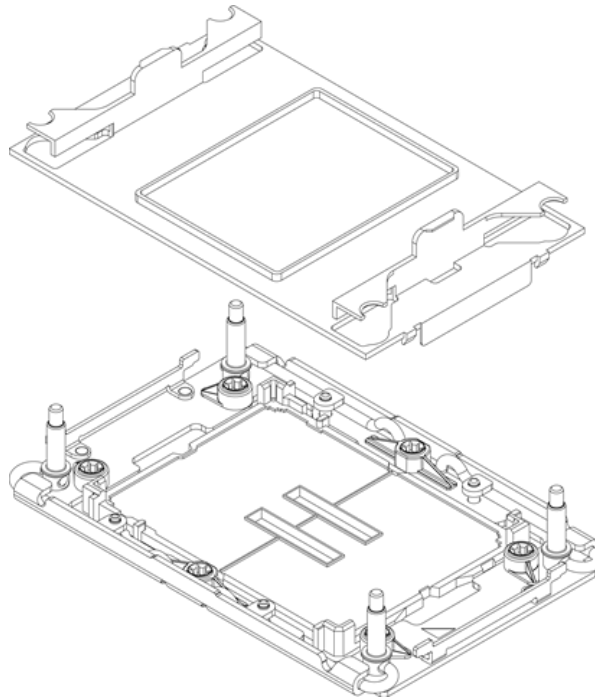

Figure 3-6. Plastic Protective Cover and Processor Socket

Overview of the Processor Heatsink Module

The Processor Heatsink Module (PHM) contains a heatsink, a processor carrier, and the processor.

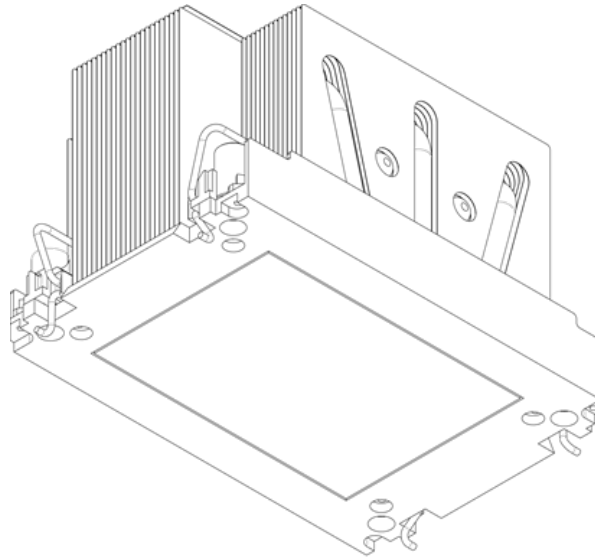

Figure 3-7. Heatsink

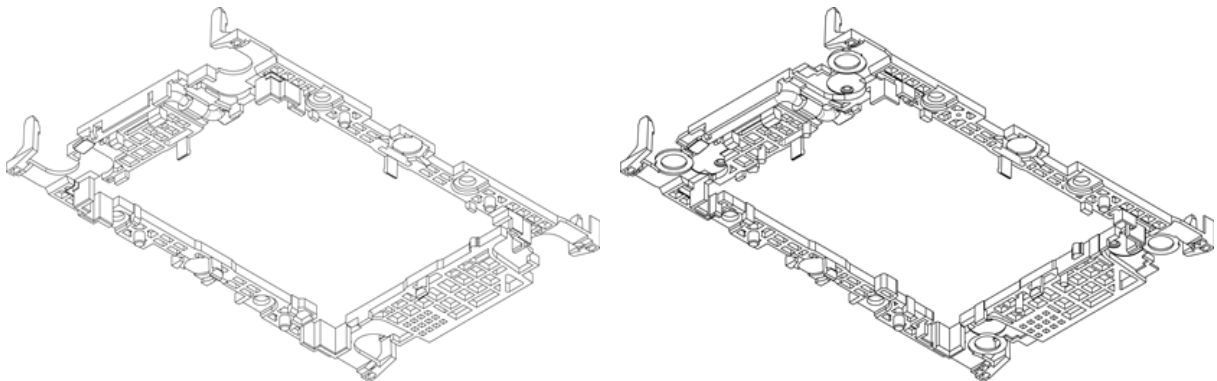

Figure 3-8. Carrier (SP XCC E2A left, SP HCC/LCC E2B right)

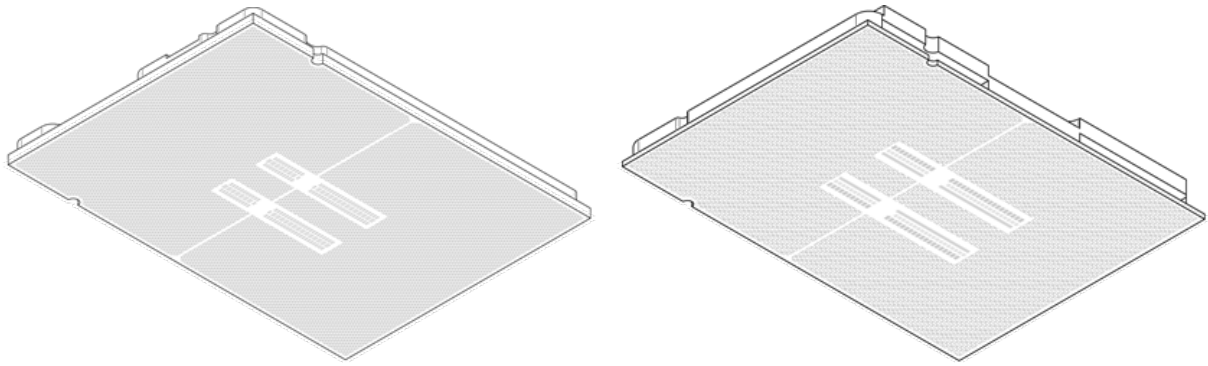

Figure 3-9. Processor (SP XCC E2A left, SP HCC/LCC E2B right)

Installing the Processor

To install the processor, follow the steps below:

1. Before installation, make sure the lever on the processor carrier is pressed down as shown below.

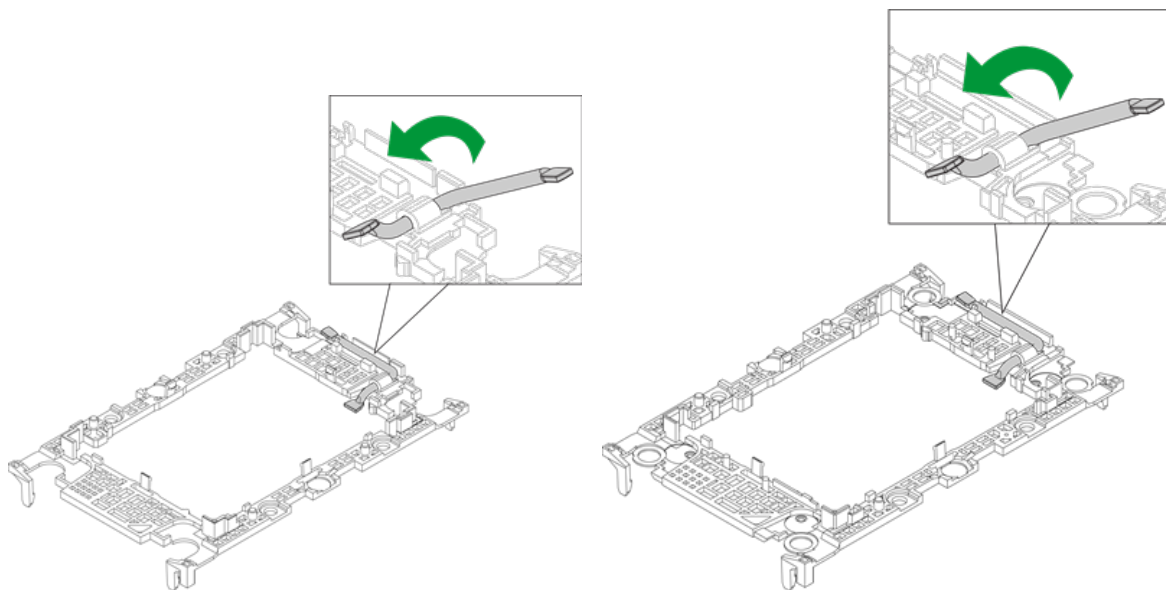

Figure 3-10. Carrier Lever (SP XCC left, SP HCC/LCC right)

2. Hold the processor with the LGA lands (gold contacts) facing up. Locate the small, gold triangle in the corner of the processor and the corresponding hollowed triangle on the processor carrier. These triangles indicate pin 1.

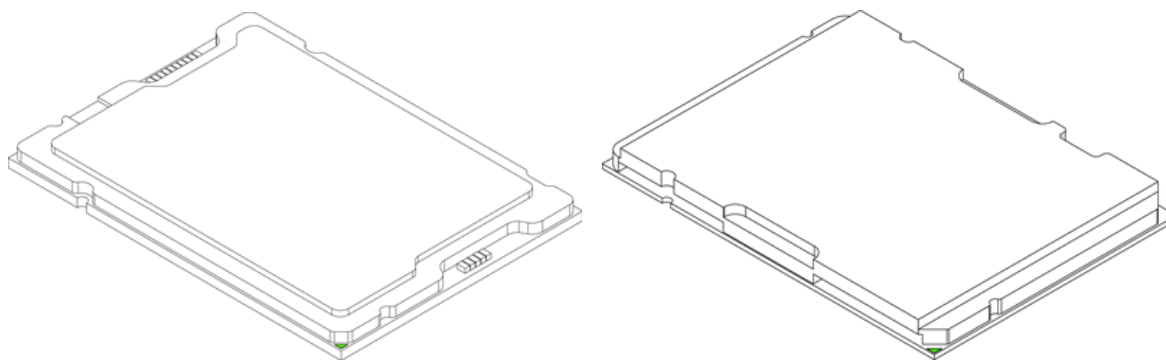

Figure 3-11. Processor (SP XCC E2A left, SP HCC/LCC E2B right)

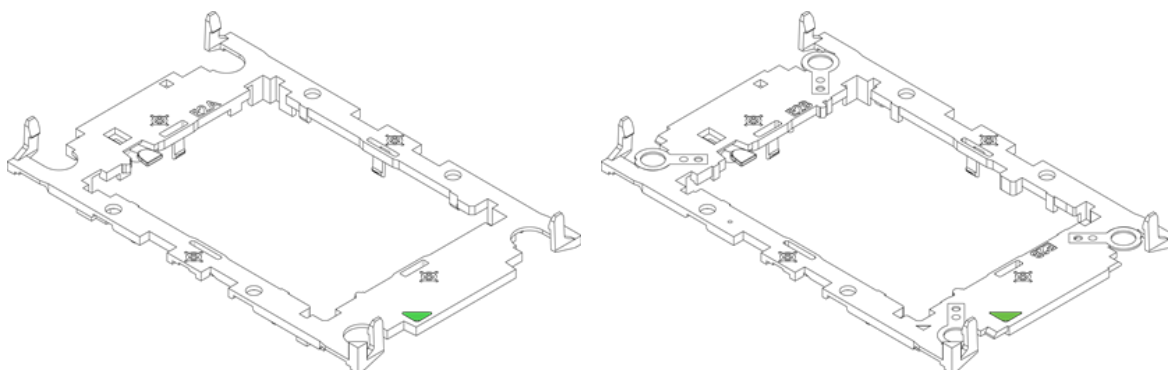

Figure 3-12. Carrier (SP XCC E2A left, SP HCC/LCC E2B right)

3. Use the triangles as a guide to carefully align and place one end of the processor into the latch marked A, and place the other end of the processor into the latch marked B as shown below.

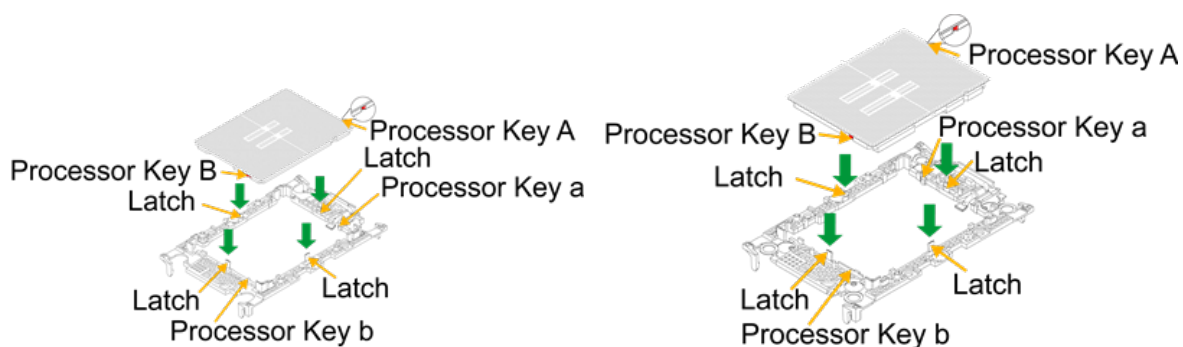

Figure 3-13. Keys and Latches Locations (SP XCC E2A left, SP HCC/LCC E2B right)

4. Examine all corners to ensure that the processor is firmly attached to the carrier.

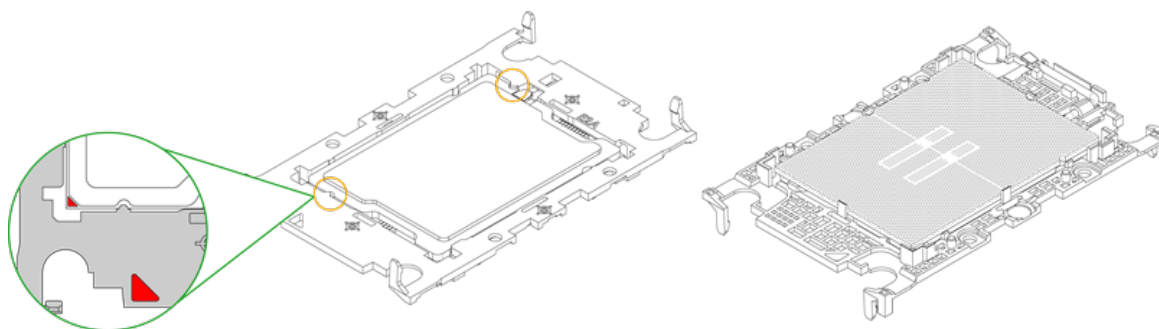

Figure 3-14. SP XCC E2A Keys and Latches

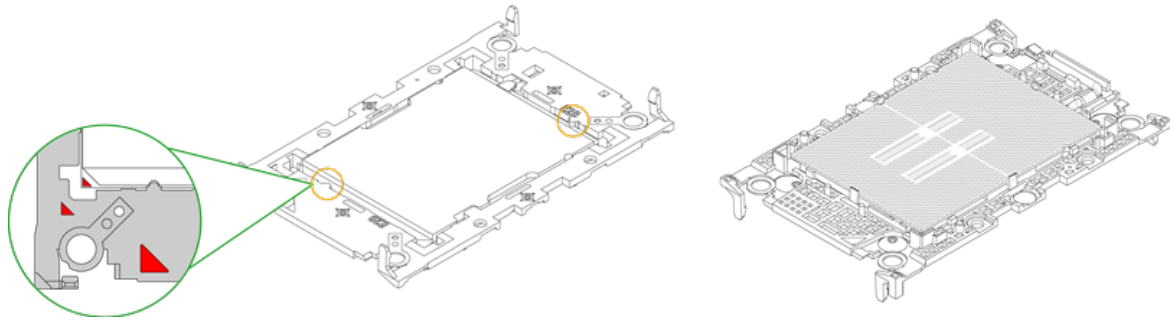

Figure 3-15. SP HCC/LCC E2B Keys and Latches Together

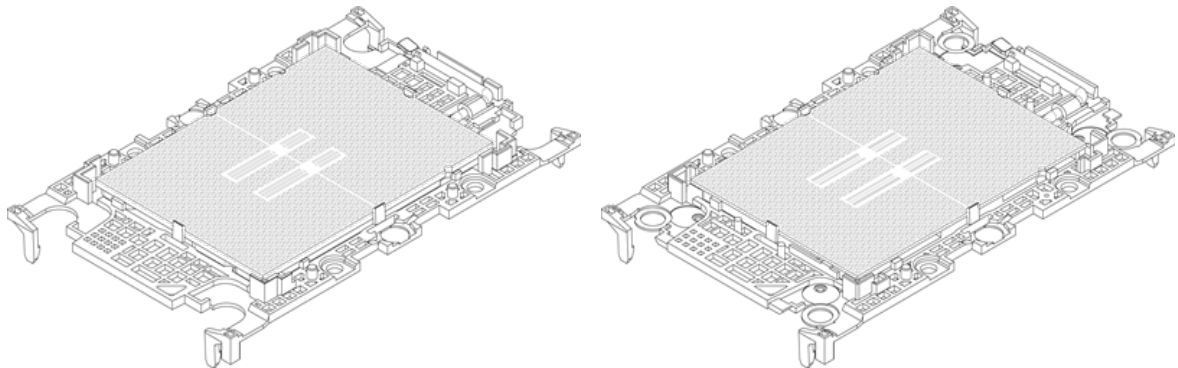

Figure 3-16. Carrier Assembly Completed (SP XCC E2A left, SP HCC/LCC E2B right)

Assembling the Processor Heatsink Module

After installing the processor into the carrier, mount it onto the heatsink to create the processor heatsink module (PHM):

1. Note the label on top of the heatsink, which marks the airflow direction. Turn the heatsink over and orient the heatsink so the airflow arrow is pointing towards the triangle on the processor.
2. If this is a new heatsink, the thermal grease has been pre-applied. Otherwise, apply the proper amount of thermal grease.
3. Hold the processor carrier so the processor's gold contacts are facing up, then align the holes of the processor carrier with the holes on the heatsink. Press the processor carrier down until it snaps into place. The plastic clips of the processor carrier will lock at the four corners.

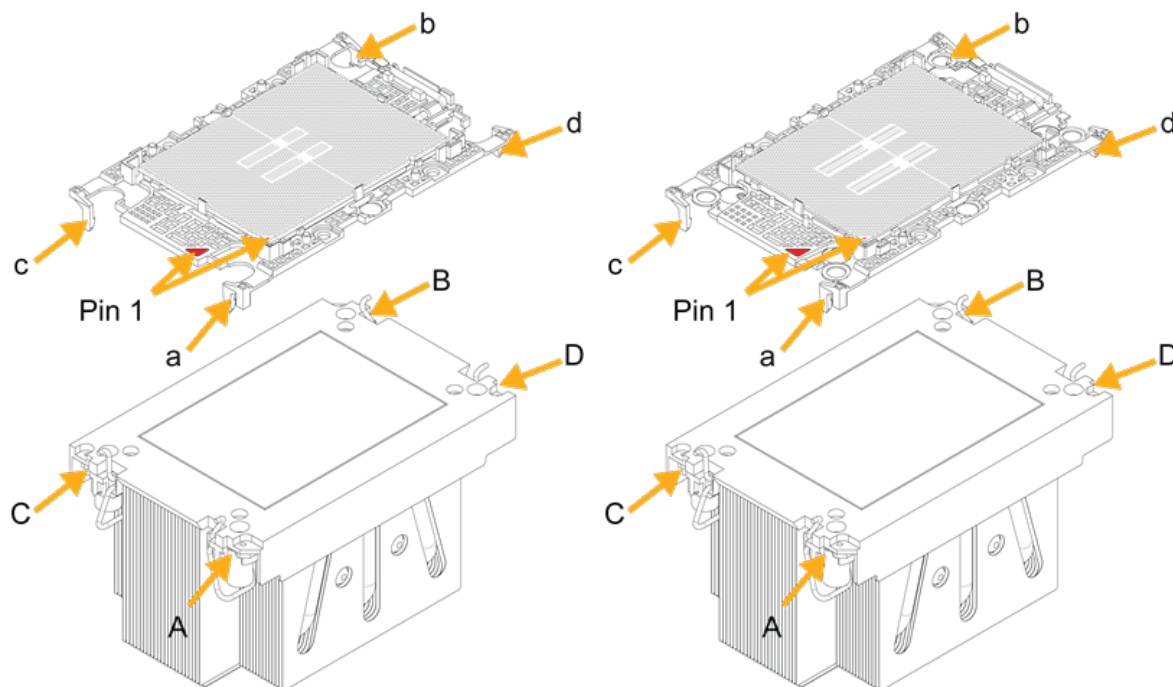

Figure 3-17. Carrier with 2U Heatsink (SP XCC left, SP HCC/LCC right)

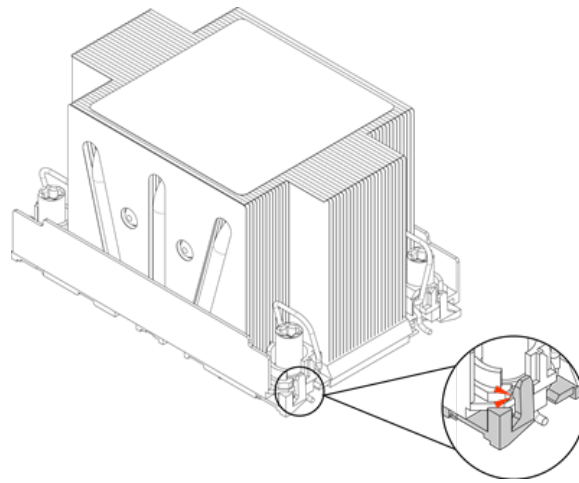

Figure 3-18. PHM Plastic Clips Locked

4. Examine all corners to ensure that the plastic clips on the processor carrier are firmly attached to the heatsink.

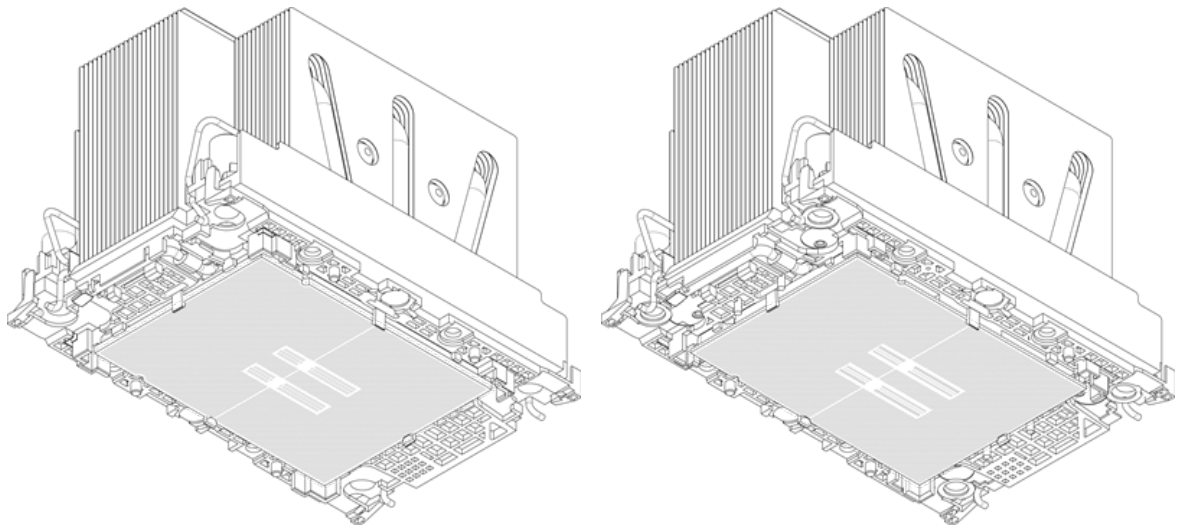

Figure 3-19. 2U PHM Completed (SP XCC left, SP HCC/LCC right)

Preparing the Processor Socket for Installation

This motherboard comes with a plastic protective cover installed on the processor socket. Remove it from the socket to install the Processor Heatsink Module (PHM). Gently pull up one corner of the plastic protective cover to remove it.

1. Press the tabs inward.

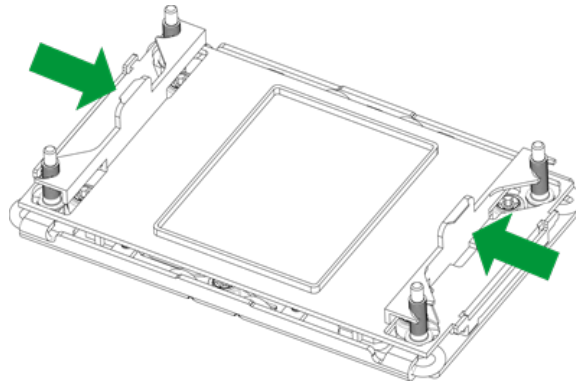

Figure 3-20. Processor Socket with Plastic Protective Cover

2. Pull up the protective cover from the socket.

Note: Do not touch or bend the socket pins.

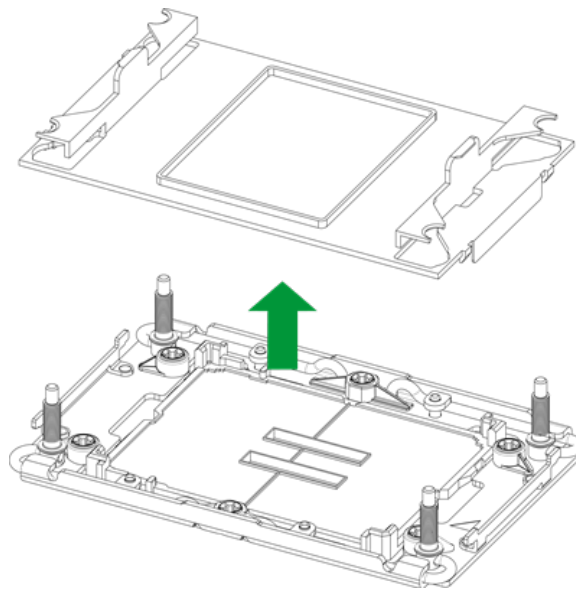
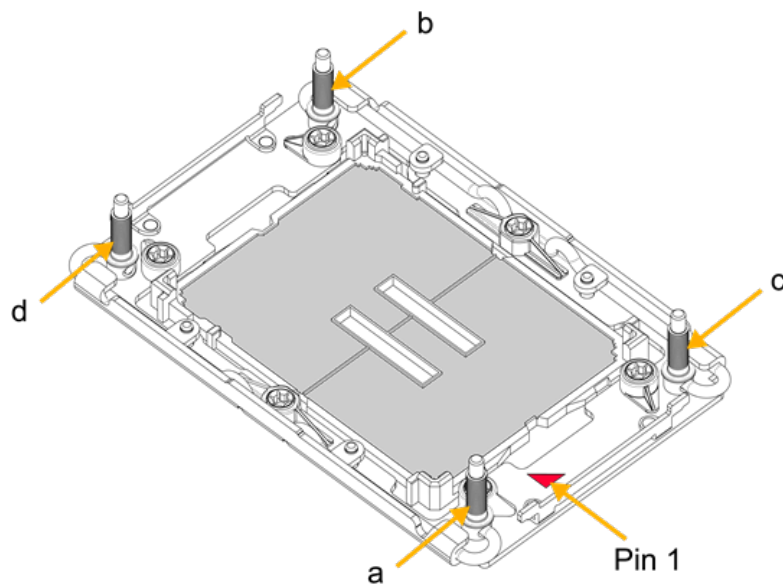

Figure 3-21. Plastic Protective Cover Removed

Preparing to Install the PHM into the Processor Socket

After assembling the Processor Heatsink Module (PHM), you are ready to install it into the processor socket. To ensure the proper installation, follow the procedures below:

1. Locate four threaded fasteners (marked a, b, c, and d) on the processor socket.



a, b, c, d: Threaded Fasteners

Figure 3-22. Threaded Fasteners

2. Locate four PEEK nuts (marked A, B, C, and D) and four rotating wires (marked 1, 2, 3, and 4) on the heatsink.

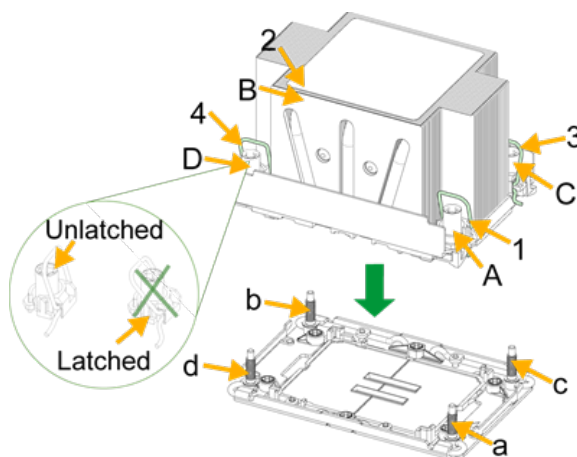

Figure 3-23. PEEK Nuts and Rotating Wires

3. Check the rotating wires (marked 1, 2, 3, and 4) to make sure that they are at unlatched positions before installing the PHM into the processor socket.

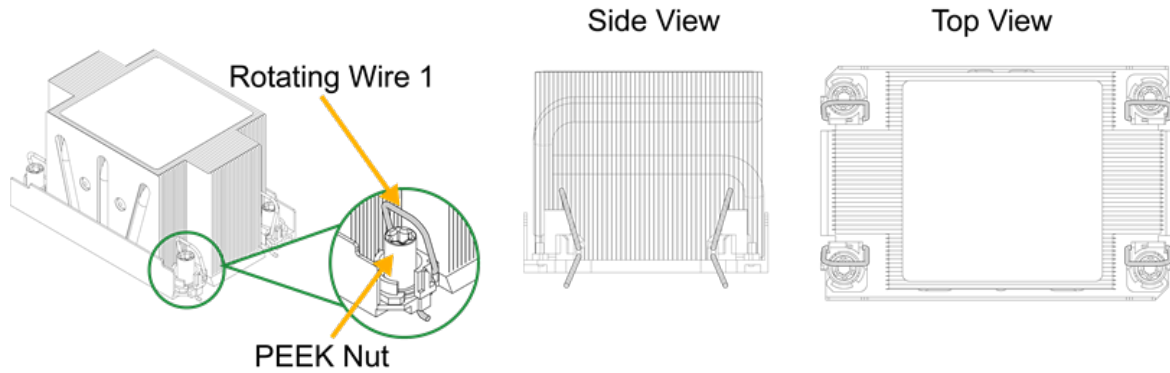

Figure 3-24. 2U Unlatched Positions

Installing the Processor Heatsink Module

1. Align pin 1 of the PHM with the printed triangle on the processor socket.
2. Make sure all four PEEK nuts of the heatsink (marked A, B, C, and D) are aligned with the threaded fasteners (marked a, b, c, and d), then gently place the heatsink on top of the processor socket.

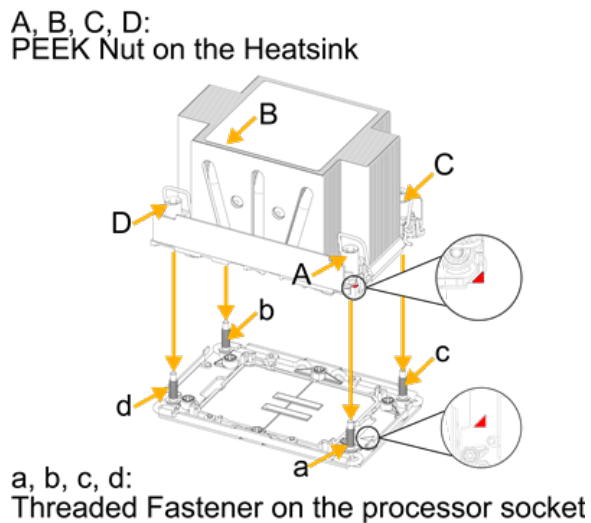

Figure 3-25. Aligning the Heatsink with the Socket

3. Press all four rotating wires outwards and make sure that the heatsink is securely latched into the processor socket.

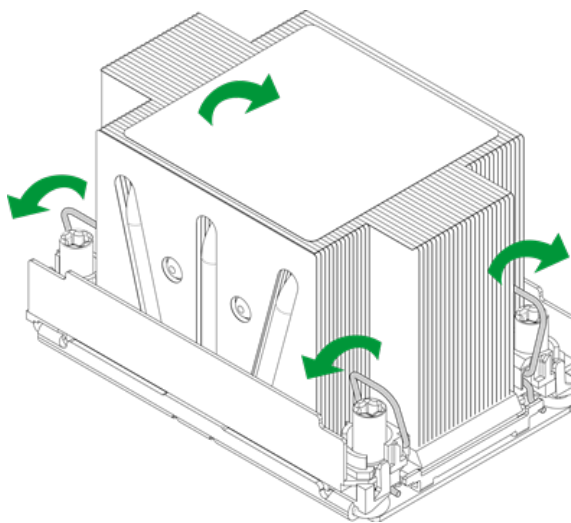

Figure 3-26. Latching the PHM

4. With a T30 bit torque driver set to a force of 8.0 in-lbf (0.904 N-m), gradually tighten the four screws to ensure even pressure. You can start with any screw, but make sure to tighten the screws in a diagonal pattern.

Important: Do not use a force greater than 8.0 in-lbf (0.904 N-m). Exceeding this force may over-torque the screw, causing damage to the processor, heatsink, and screw.

5. Examine all corners to ensure that the PHM is firmly attached to the socket.

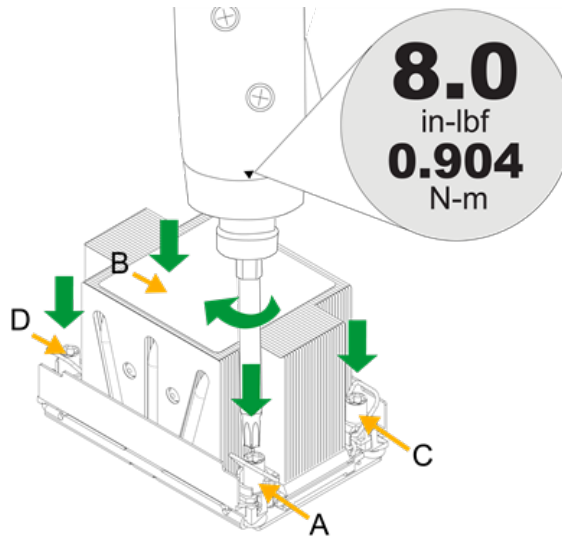

Figure 3-27. Installing the PHM with a Torque Driver

Removing the Processor Heatsink Module

Before removing the processor heatsink module (PHM) from the motherboard, shut down the system and then unplug the AC power cord from all power supplies.

Then follow the steps below:

1. Use a screwdriver to loosen the four screws. You can start with any screw, but make sure to loosen the screws in a diagonal pattern.

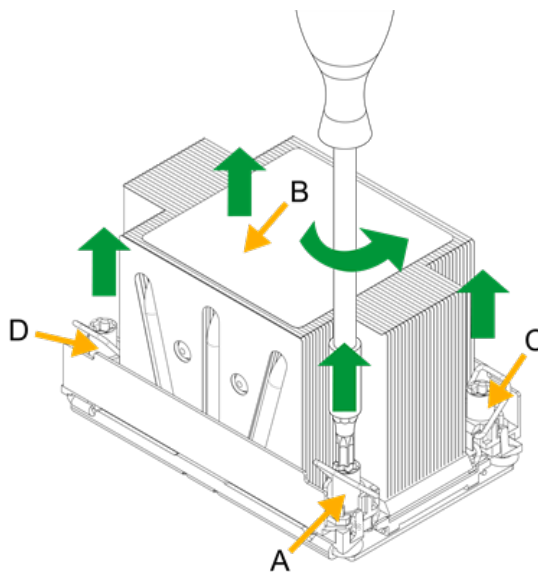

Figure 3-28. Loosening the Screws

2. Press the four rotating wires inwards to unlatch the PHM from the socket.

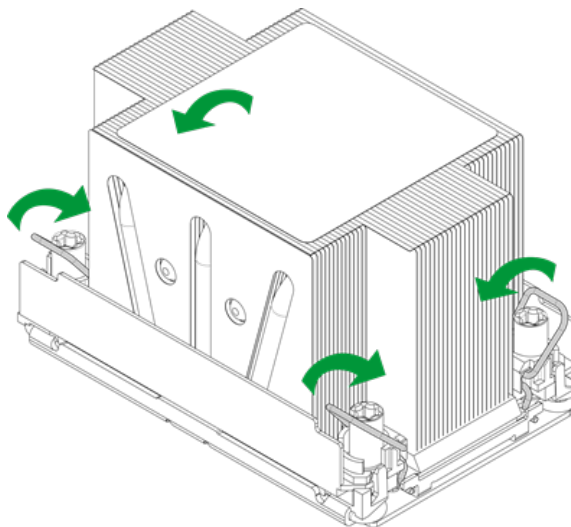

Figure 3-29. Unlatching the PHM

3. Gently lift the PHM upwards to remove it from the socket.

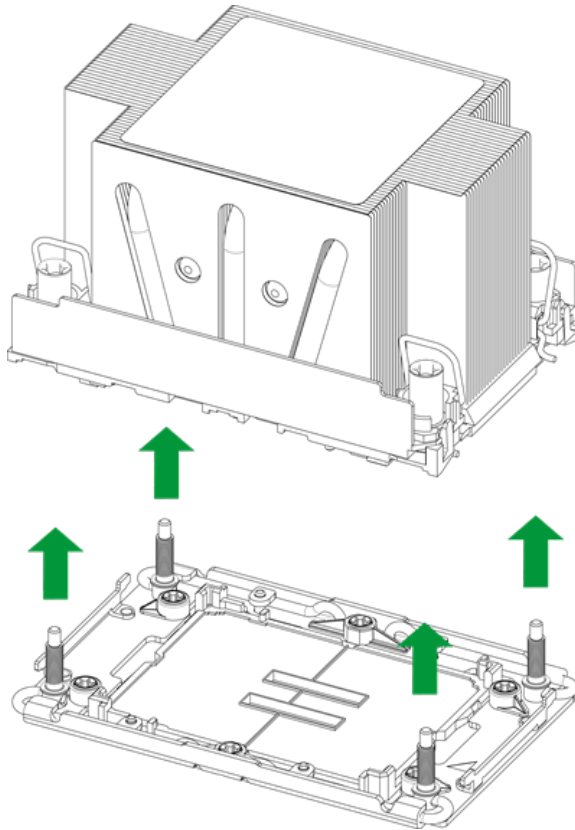

Figure 3-30. Removing the PHM from the Socket

4. To remove the processor from the heatsink, gently lift the lever from the processor carrier.

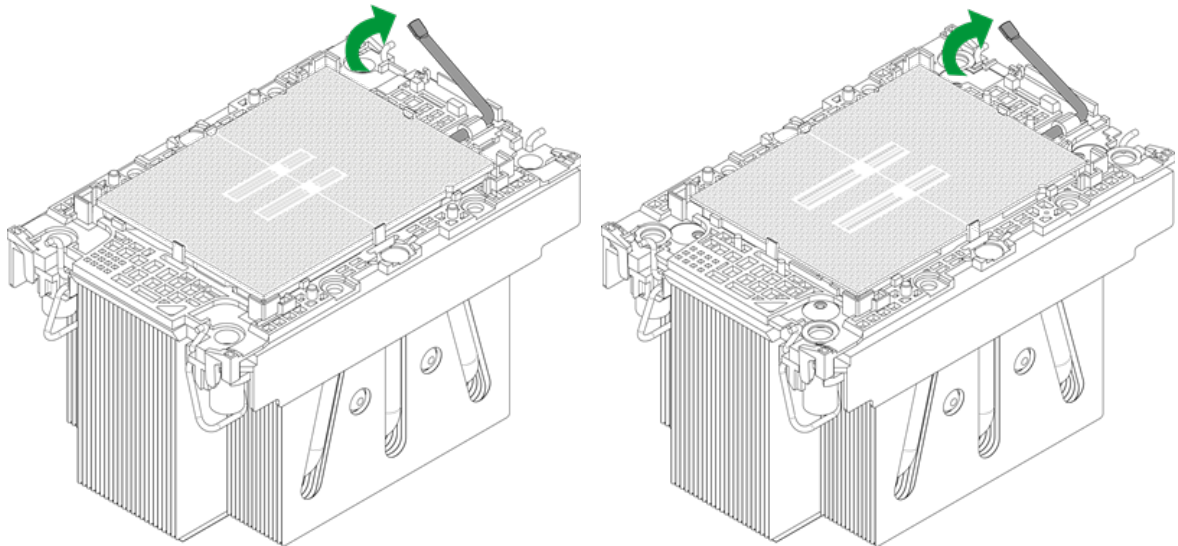

Figure 3-31. Carrier with 2U Heatsink (SP XCC left, SP HCC/LCC right)

5. To remove the processor, move the lever to its unlocked position and gently remove the processor.

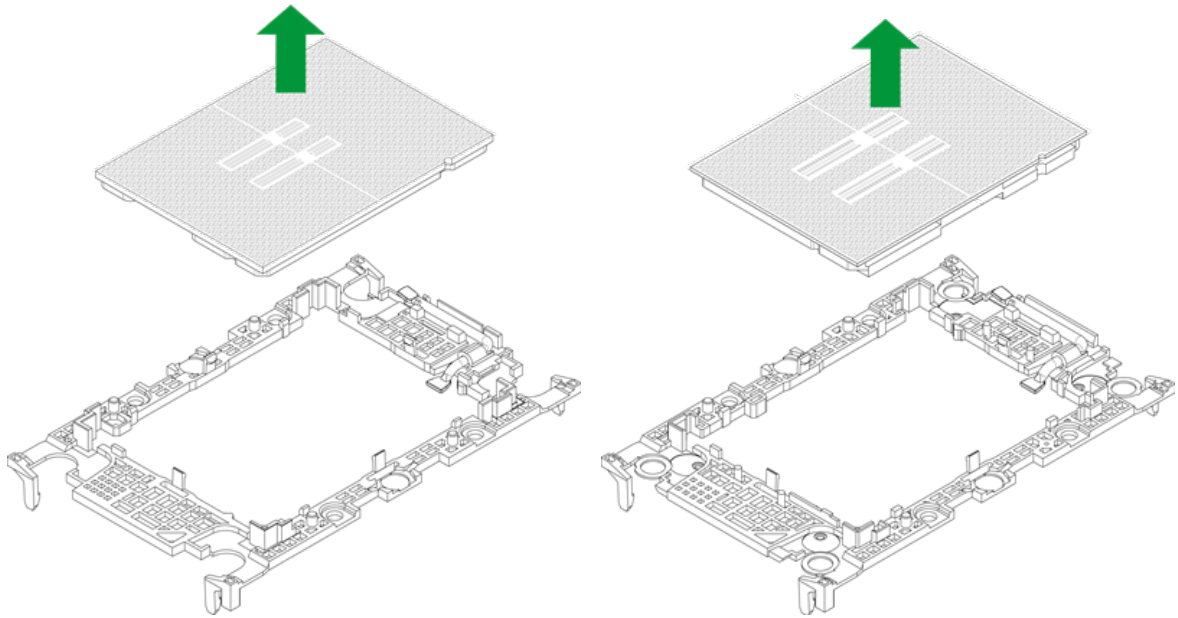

Figure 3-32. Removing the Processor (SP XCC left, SP HCC/LCC right)

3.5 Memory Support and Installation

Important: To prevent any damage, exercise extreme care when installing or removing memory modules.

Note: Check the Supermicro website for recommended memory modules.

General Guidelines for Optimizing Memory Performance

- It is recommended to use DDR5 memory of the same type, size, and speed.
- Mixed DIMM speeds can be installed. However, all DIMMs will run at the speed of the slowest DIMM.
- The motherboard will support an odd number amount of memory modules. However, to achieve the best memory performance, a balanced memory population is recommended.

Memory Support

Note: Check the Supermicro website for recommended memory modules.

Important: Exercise extreme care when installing or removing memory modules to prevent any possible damage.

The X14DBI-T motherboard supports up to 2 TB of RDIMM DDR5 ECC memory with speeds of up to 6400 MT/s (1DPC). In addition, MRDIMM DDR5 memory with speeds up to 8000 MT/s (1DPC) is also supported.

To enhance memory performance and ensure system stability, do not mix memory modules of different speeds, different sizes, and different types in your server.

Note: Memory speed/capacity support depends on the processors used in the system.

DDR5-6400 Memory Support for Intel® Xeon® 6700/6500-Series Processors with P-Cores						
Type	Ranks Per DIMM, Data Width (Stack)	DIMM Capacity (GB)			Speed (MT/s); Voltage (V); Slots per Channel (SPC) and DIMMs per Channel (DPC)	
		DRAM Density				
		16 Gb	24 Gb	32 Gb	1DPC/2SPC	
		1DPC	1DPC	1DPC	+1.1 V	
RDIMM	1Rx8	16 GB	24 GB	-	6400, 6000, 5600, 5200, 4800 (DDR5-6400 rated RDIMMs only)	
	1Rx4	32 GB	48 GB	-		
	2Rx8	32 GB	48 GB	-		
	2Rx4	64 GB	96 GB	128 GB*		
3DS RDIMM	4Rx4	-	-	-		
	8Rx4	-	-	256 GB^A		
MRDIMM	2Rx8	32 GB	-	-		8000, 7200 (MRDIMM-8800 only)
	2Rx4	64 GB	-	-		

Notes:

- The items marked with an asterisk (*) are supported in 1S/2S/4S systems. The items with circumflex (^) are supported in 8S systems. All others support 1S/2S only.
- SYS-622B-TRT does not support MCR-DIMM.

CXL Memory Configuration Support for Intel® Xeon® 6700/6500-Series Processors with P-Cores									
Native DDR5 Memory Per Socket				CXL Memory Per Socket					
Slot 0 DIMM Ranks	Slot 0 DIMM Capacity (GB)	DIMM Type	DRAM Density (Gb)	CXL Memory Channels	CXL Memory Type	CXL Capacity Per Device/Module	CXL Interleave	CXL Mode	4S and 8S support
2Rx4	96	10x4	24	2+2	DDR5 x8	96 GB [#]	1x4*, 2x2, 4x1	1LM+Vol	Yes
2Rx4	128	10x4	32	2+2	DDR4 x8 [#] , DDR x8	128 GB	1x4*, 2x2, 4x1	1LM+Vol	Yes

CXL Memory Configuration Support for Intel® Xeon® 6700/6500-Series Processors with P-Cores									
2Rx4	128	10x4	32	2+2	DDR5 x8	128 GB	hetero x12	Hetero	Yes
2Rx4	64	10x4	16	2+2+2	DDR5 x8	128 GB	1x6*, 2x3, 3x2	1LM+Vol	No
2Rx4	64	10x4	16	2	DDR5 x8	128 GB	1x2*	1LM+Vol	No
2Rx4	64	10x4	16	1+1	DDR5 x16	2ch 128 GB	1x2*	Intel Flat Memory Mode	Yes

Notes:

- The items with an asterisk (*) are the default settings in the BIOS.
- The Intel® Xeon® 6700/6500-series processors with P-cores CXL memory configurations are 1DPC ('Slot 0') only for native DDR5.
- CXL Memory Channel: number of devices per root port, with root ports separated by "+". e.g. 2+2+2+2 = four root ports populated with two devices per root port.
- CXL Interleave: sets x ways, e.g. 2x4 = One set of two modules, interleaved four-way
- CXL Modes:
 - 1LM+Vol= Native DDR5 ('1LM') and (volatile) CXL memory visible to SW as separate tiers, separately interleaved.
 - Hetero x12 = DDR5 and (volatile) CXL memory interleaved together in one 12-way set.
 - Flat Memory Mode = HW manages data movement between DDR5 and CXL memory, total capacity visible to SW
- SYS-622B-TRT does not support MCR-DIMM.

DDR5-6400 Memory Support for Intel® Xeon® 6700-Series Processors with E-Cores (Only DDR5-6400 Related RDIMMs Supported)						
Type	Ranks Per DIMM, Data Width (Stack)	DIMM Capacity (GB)			Speed (MT/s); Voltage (V); Slots per Channel (SPC) and DIMMs per Channel (DPC)	
		DRAM Density				
		16 Gb	24 Gb	32 Gb	1DPC/2SPC	
		1DPC	1DPC	1DPC	+1.1 V	
RDIMM	1Rx4	32 GB	-	-	6400, 6000, 5600, 5200, 4800 (DDR5-6400 rated RDIMMs only)	
	2Rx8	32 GB	-	-		
	2Rx4	64 GB	96 GB	-		
	2Rx4	-	-	128 GB		
3DS RDIMM	4Rx4	-	-	256 GB		

CXL Memory Configuration Support for Intel® Xeon® 6700-Series Processors with E-Cores								
Native DDR5 Memory Per Socket				CXL Memory Per Socket				
Slot 0 DIMM Ranks	Slot 0 DIMM Capacity (GB)	DIMM Type	DRAM Density (Gb)	CXL Memory Channels	CXL Memory Type	CXL Capacity Per Device/ Module	CXL Interleave	CXL Mode
2Rx4	64	10x4	16	2+2	DDR5 x8	64 GB	1x4*, 2x2, 4x1	1LM+Vol
2Rx4	64	10x4	16	1+1	DDR5 x16	128 GB	1x2*, 2x1	1LM+Vol
1Rx4	32	10x4	16	2	DDR5 x8	128 GB	1x2*	Intel Flat Memory Mode

Notes:

- The items with an asterisk (*) are the default settings in the BIOS.
- The Intel® Xeon® 6700-series processors with E-cores CXL memory configurations are 1DPC ('Slot 0') only for native DDR5.
- CXL Memory Channel: number of devices per root port, with root ports separated by "+," e.g. 2+2+2+2 = four root ports populated with two devices per root port.
- CXL Interleave: sets x ways, e.g. 2x4 = One set of two modules, interleaved four-way.
- CXL Modes:
 - 1LM + Vol = DDR5 ('1LM') and (volatile) CXL memory visible to SW as separate tiers, separately interleaved.
 - Flat Memory Mode = HW manages data movement between DDR5 and CXL memory, total capacity visible to SW.
- SYS-622B-TRT does not support MCR-DIMM.

DDR5 Memory Population Table for the X14DBI-T Motherboard (2 Processors and 16 DIMMs, 1DPC)	
1 Processor DIMM Counts	Memory Population Sequence (1DPC)
1 Processor and 1 DIMM	P1-DIMMA1
1 Processor and 4 DIMMs	P1-DIMMA1/P1-DIMMC1/P1-DIMME1/P1-DIMMG1 P1-DIMMB1/P1-DIMMD1/P1-DIMMH1/P1-DIMMF1
1 Processor and 8 DIMMs	P1-DIMMA1/P1-DIMMB1/P1-DIMMC1/P1-DIMMD1/P1-DIMME1/P1-DIMMF1/P1-DIMMG1/P1-DIMMH1
2 Processor DIMM Counts (Recommended)	Memory Population Sequence (1DPC)
2 Processors and 8 DIMMs	P1-DIMMA1/P1-DIMMC1/P1-DIMME1/P1-DIMMG1 P2-DIMMA1/P2-DIMMC1/P2-DIMME1/P2-DIMMG1
2 Processors and 8 DIMMs	P1-DIMMB1/P1-DIMMD1/P1-DIMMF1/P1-DIMMH1 P2-DIMMB1/P2-DIMMD1/P2-DIMMF1/P2-DIMMH1

DDR5 Memory Population Table for the X14DBI-T Motherboard (2 Processors and 16 DIMMs, 1DPC)

2 Processors and 16 DIMMs	P1-DIMMA1/P1-DIMMB1/P1-DIMMC1/P1-DIMMD1/P1-DIMME1/P1-DIMMF1/P1-DIMMG1/P1-DIMMH1 P2-DIMMA1/P2-DIMMB1/P2-DIMMC1/P2-DIMMD1/P2-DIMME1/P2-DIMMF1/P2-DIMMG1/P2-DIMMH1
----------------------------------	--

Notes:

- The memory configurations with an asterisk (*) are recommended by Supermicro for optimal memory performance.
- DIMMs must be all DDR5-6400 rated RDIMMs.
- All DIMMs in a channel must have the same number of ranks (unless explicitly specified otherwise).
- x8 DIMMs and x4 DIMMs cannot be mixed in the same channel or same processor socket (see the memory support table above).
- Rank mixing is not allowed.
- Vendor mixing is not allowed.
- SYS-622B-TRT does not support MCR-DIMM.

DIMM Installation

Important: To avoid causing any damage to the memory module or the DIMM socket, do not use excessive force when pressing the release tabs on the ends of the DIMM socket. Handle memory modules with care. To avoid ESD-related damage to your memory modules or components, carefully follow all the instructions given in ["Static-Sensitive Devices"](#) on page 44.

1. Insert the desired number of DIMMs into the memory slots based on the recommended DIMM population table earlier in this section.
2. Push the release tabs outwards on both ends of the DIMM slot to unlock it.

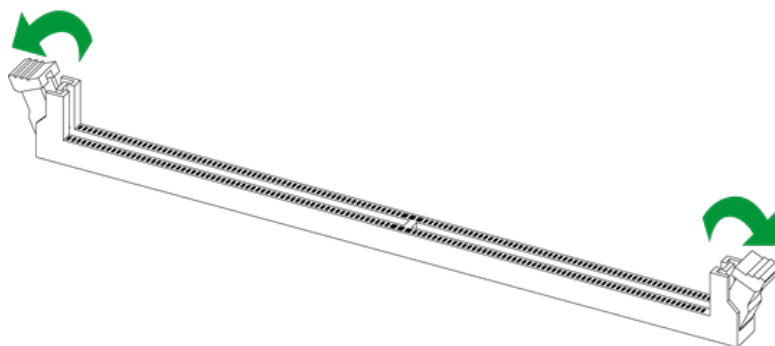

Figure 3-33. Unlocking the DIMM Slot

3. Align the key of the DIMM with the receptive point on the memory slot.

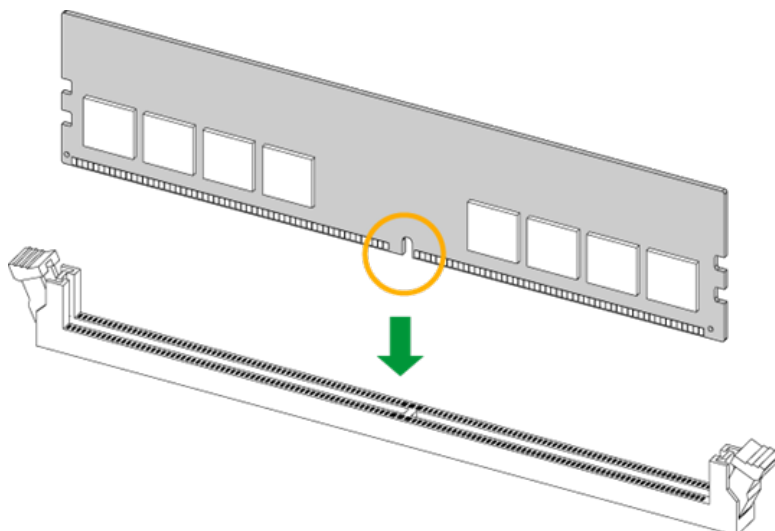

Figure 3-34. Aligning the DIMM Slot with the Receptive Point

- Align the notches on both ends of the module against the receptive points on the ends of the slot.

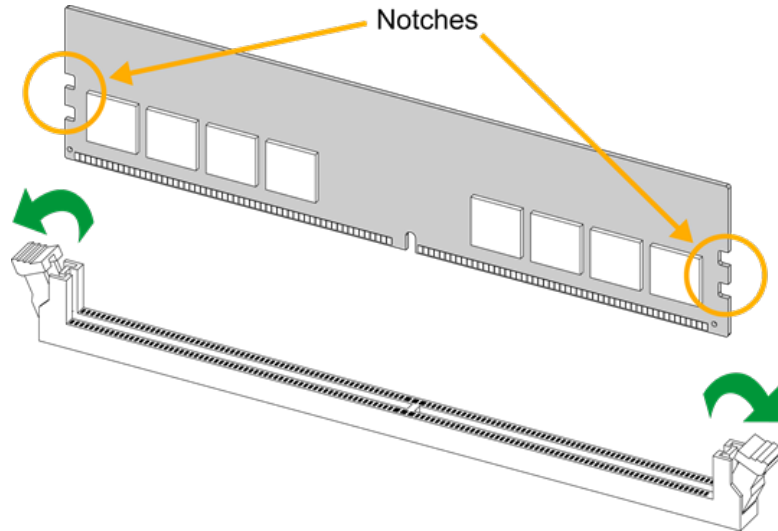

Figure 3-35. Aligning the Notches

- Press both ends of the module straight down into the slot until the module snaps into place.
- Press the release tabs to the lock positions to secure the DIMM into the slot.

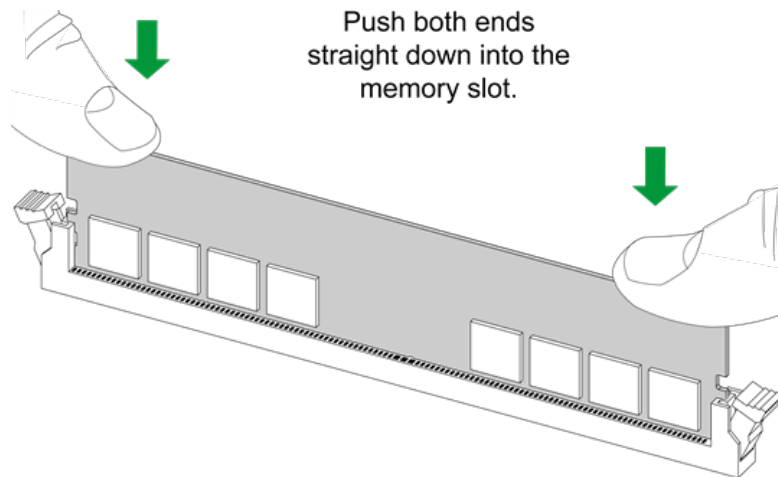

Figure 3-36. Securing the DIMM

For a detailed diagram of the X14DBI-T motherboard, see the layout under ["Motherboard Quick Reference"](#) on page 23.

DIMM Removal

Important: To avoid causing any damage to the memory module or the DIMM socket, do not use excessive force when pressing the release tabs on the ends of the DIMM socket. Handle memory modules with care. To avoid ESD-related damage to your memory modules or components, carefully follow all the instructions given in "[Static-Sensitive Devices](#)" on [page 44](#).

Press both release tabs on the ends of the DIMM socket to unlock it. Once the DIMM is loosened, remove it from the memory slot.

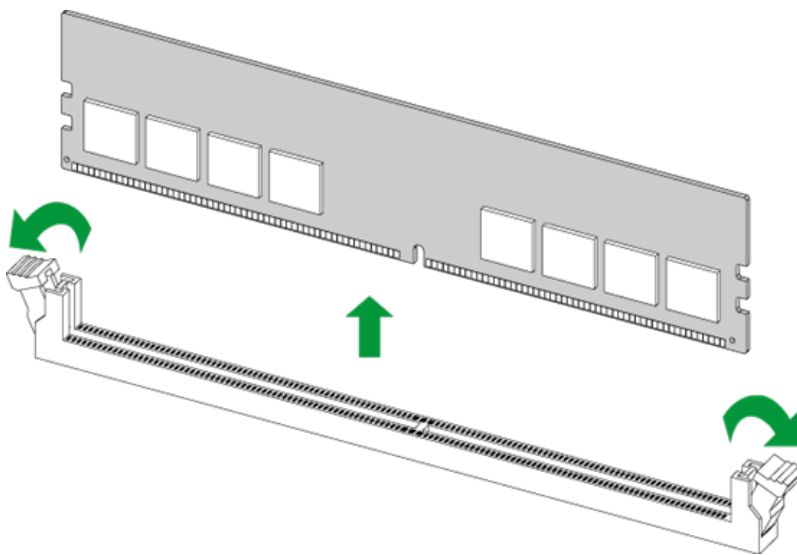

Figure 3-37. Unlocking the DIMM Slot

For a detailed diagram of the X14DBI-T motherboard, see the layout under "[Motherboard Quick Reference](#)" on [page 23](#).

3.6 Motherboard Battery Removal and Installation

Battery Removal

To remove the onboard battery, follow the steps below:

1. Power off your system and unplug your power cable.
2. Place the system on a workbench.
3. Locate the onboard battery as shown below.
4. Using a tool such as a pen or a small screwdriver, push the battery lock outwards to unlock it. Once unlocked, the battery will pop out from the holder.
5. Remove the battery.

Proper Battery Disposal

Important: Handle used batteries carefully. Do not damage the battery in any way; a damaged battery may release hazardous materials into the environment. Do not discard a used battery in the garbage or a public landfill. Comply with the regulations set up by your local hazardous waste management agency to dispose of your used battery properly.

Battery Installation

To install an onboard battery, follow steps 1 and 2 above and continue below:

Important: When replacing a battery, be sure to only replace it with the same type.

1. Identify the battery's polarity. The positive (+) side should be facing up.
2. Insert the battery into the battery holder and push it down until you hear a click to ensure that the battery is securely locked.

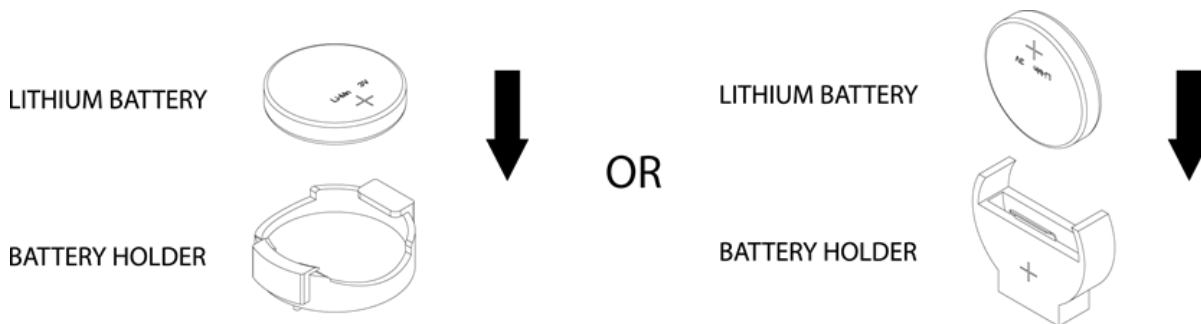

Figure 3-38. Installing a Battery

3.7 Storage Drives

The SYS-622B-TRT chassis supports eight hot-swap 3.5" SATA storage drives. The 3.5" SATA drives are mounted in drive carriers that simplify their removal from the chassis. These carriers also help promote proper airflow. Optionally, for the front drives the system supports four front 3.5" NVMe drives. For the rear 2.5" hot-swap drives, the system supports two SATA drives with specific optional hardware added.

Note: Enterprise-level storage modules are recommended for use in Supermicro servers.

Hot-Swap for NVMe Drives

Supermicro servers support NVMe surprise hot-swap. For even better data security, NVMe orderly hot-swap is recommended. NVMe drives can be ejected and replaced remotely using BMC.

Note: If you are using VROC, see "[Intel Virtual RAID on CPU \(VROC\)](#)" on page 118 in this manual instead.

Ejecting a Drive

1. **BMC > Server Health > NVMe SSD**
2. Select Device, Group, and Slot, and click **Eject**. After ejecting, the drive Status LED indicator turns green.
3. Remove the drive.

Note that Device and Group are categorized by the CPLD design architecture.

A Slot is the slot number on which the NVMe drives are mounted.

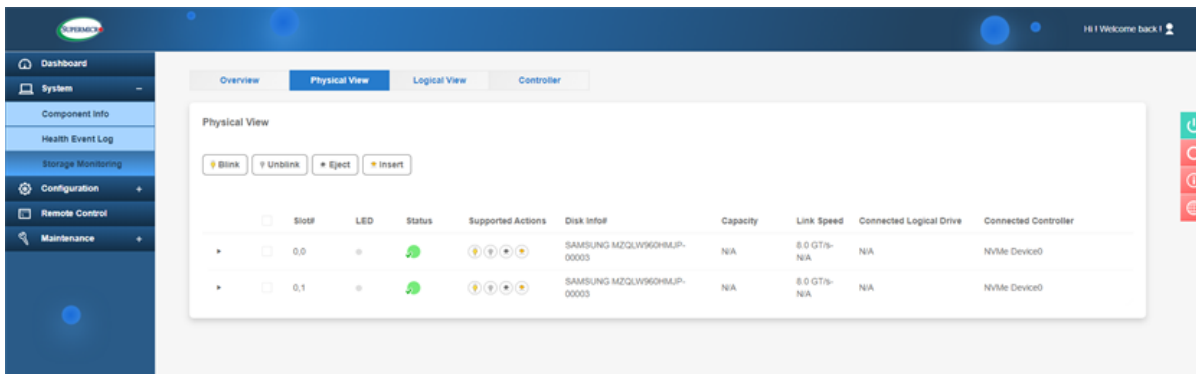

Figure 3-39. BMC Screenshot

Replacing a Drive

1. Insert the replacement drive.
2. **BMC > System > Storage Monitor > Physical View**
3. Select Device, Group, and slot and click **Insert**. The drive Status LED indicator flashes red, then turns off. The Activity LED turns blue.

3.8 System Cooling

Refer to the following sections for information about the cooling capabilities of the SYS-622B-TRT server.

Fans

Fan speed is controlled by a system temperature setting in the BMC. If a fan fails, the remaining fans will ramp up to full speed. The system can continue to run with a failed fan. Replace any failed fan at your earliest convenience with the same type and model. Failed fans can be identified through the BMC.

Changing a System Fan

1. Determine which fan is failing. If possible, use BMC. If not, remove the chassis cover while the power is on, and examine the fans to determine which one has failed.
2. Remove power from the system.
3. Place the system on a workbench and remove the chassis cover if you have not already done so.
4. If applicable, remove the fan cable from the midplane for the failed fan.
5. Lift the fan up and out of the chassis.
6. Put the new fan back into the chassis and reconnect the cable.
7. Power on the system to confirm that the fan is working properly before replacing the chassis cover.

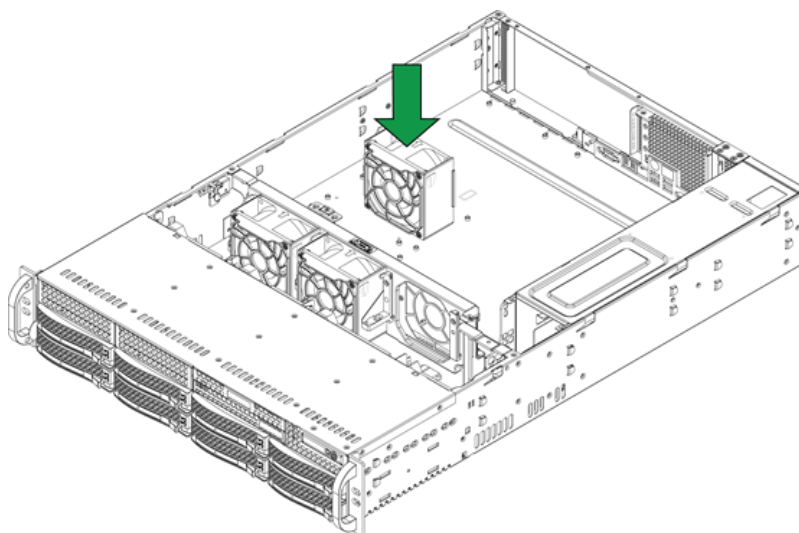

Figure 3-40. Installing/Removing System Fans

Air Shrouds

Air shrouds concentrate airflow to maximize fan efficiency.

Installing an Air Shroud

The motherboard, any expansion cards, and all components must be installed in the chassis.

1. Place the system on a workbench.
2. Ensure the CPU, CPU heatsinks, and configured DIMMs are installed.
3. Align the air shroud with the motherboard.
4. Install directly onto the motherboard. There are no screws to set.

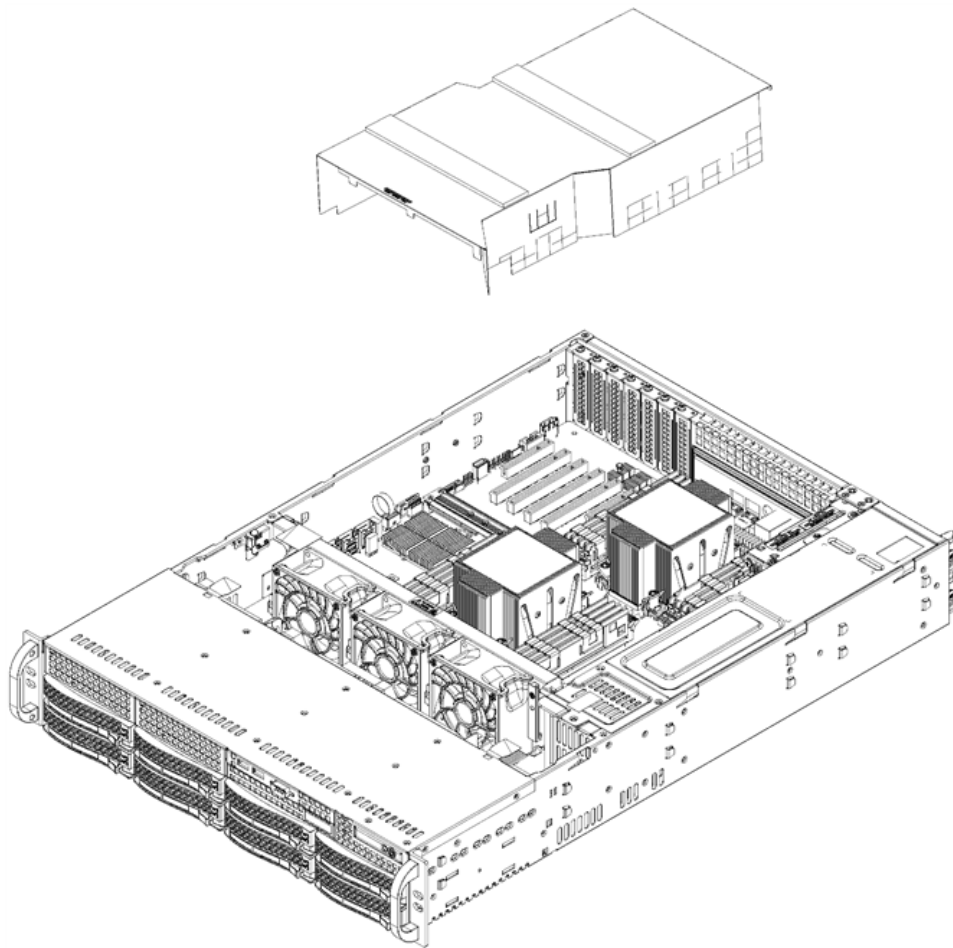

Figure 3-41. Installing an Air Shroud

3.9 Expansion Cards

Refer to the following sections for information on the expansion cards supported by the SYS-622B-TRT server.

PCIe Cards

The SYS-622B-TRT server includes slots for PCI expansion cards. It supports four low-profile cards.



Figure 3-42. Rear Expansion Card Locations

Expansion Slot Locations	
Location	Description
1	One PCIe 5.0 x8 LP slot (CPU1)
2, 4	One PCIe 5.0 x16 LP slot (CPU1)
3, 5	One PCIe 5.0 x16 LP slot (CPU2)
6	One PCIe 5.0 x8 LP slot (CPU2)

Installing Expansion Cards

1. Power down the system as described in ["Removing Power"](#) on page 1. Remove the chassis from the rack and set it on a work bench (safety area).
2. Open the chassis cover as described in ["Accessing the System"](#) on page 43.
3. Remove the screw holding the cover in place for each low-profile PCI slot you want to use. Keep this screw for later use.
4. Install the expansion cards to the motherboard.

5. Secure each card to the chassis using the card's L bracket and the screw previously removed.
6. Replace the chassis cover, plug the power cords into the rear of the power supply modules, and power up the system.

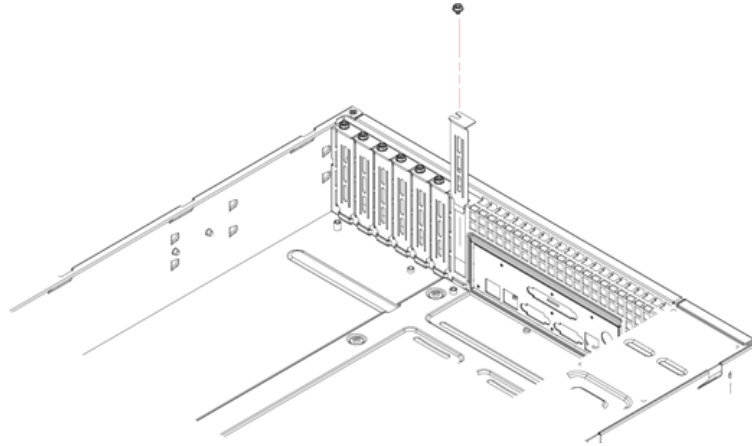

Figure 3-43. Removing L Bracket

3.10 Power Supply

The SYS-622B-TRT server includes two hot-plug power supply modules. These modules will automatically sense and operate at an input voltage between 100–240 V. Note that different input voltages will result in different maximum power output levels.

In the event of a power module failure, the other power module will continue to power the system on its own. Failed power supply modules can be replaced without powering down the system. Replacement modules can be ordered directly from Supermicro.

Power Supply Indicators		
Power Supply Condition	Green LED	Amber LED
No AC Power to Power Supply	Off	Off
Power Supply critical events causing a shutdown/failure/OCP/OVP/Fan Fail/OTP/UVP	Off	On
Power Supply Warning Events Where the power supply continues to operate; high temperature; over voltage; under voltage, etc.	Off	1 Hz blinking
AC present only 12 VSB ON (PS OFF)	1 Hz blinking	Off
Output ON and OK	On	Off
AC cord unplugged and in redundant mode	Off	On

Replacing the Power Supply

1. Unplug the AC power cord from the failed power supply module.
2. Push and hold the release tab on the back of the power supply.
3. Grasp the handle of the power supply and pull it out of its bay.
4. Push the new power supply module into the power bay until it clicks into the locked position.
5. Plug the AC power cord back into the power supply module.

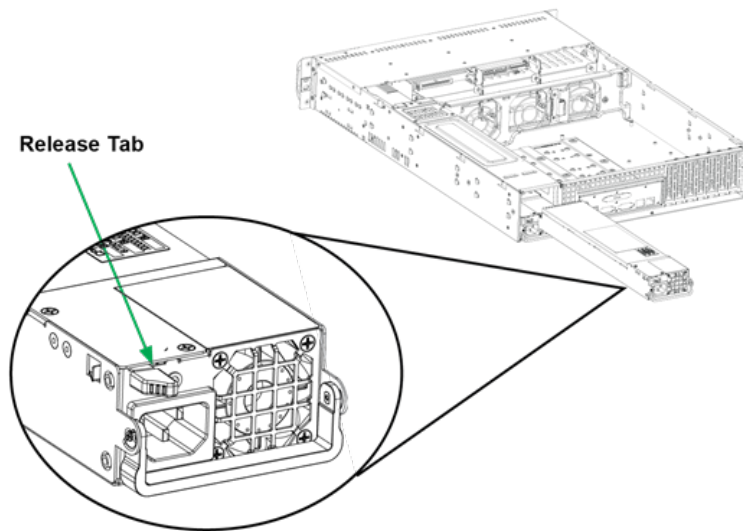

Figure 3-44. Installing a Power Supply Module

Chapter 4:

Motherboard Connections, Jumpers, and LEDs

This section describes the connections on the motherboard and provides pinout definitions. Note that depending on how the system is configured, not all connections are required. The LEDs on the motherboard are also described here. A motherboard layout indicating component locations may be found in the ["Introduction" on page 12](#). More detail can be found in the X14DBI-T motherboard manual.

Review the ["Standardized Warning Statements for AC Systems" on page 155](#) before installing or removing components.

4.1 Power Supply and Power Connections	85
ATX Power Connectors	85
4.2 Headers and Connections	86
Backplane SMBus Header	86
Chassis Intrusion	86
COM Header	86
External BMC I ² C Header	87
Fan Headers	87
M.2 M-Key PCIe 5.0 x4 Slots	88
MCIO PCIe 5.0 x8 Connectors	88
NC-SI Connection	88
NVMe SMBus Header	88
Power SMB (I ² C) Header	89
SATA Ports	89
Standby Power	90
TPM/Port 80 Header	90
USB Header	91
VGA Header	91
VROC RAID Key Header	91
4.3 Front Control Panel Header	93
Power On and BMC/BIOS Status LED Button	93
Reset Button	94

Power Fail LED	94
Overheat/Fan Fail and UID LED	95
NIC1/NIC2 (LAN1/LAN2)	95
HDD LED/UID Switch	96
Power LED	96
NMI Button	97
4.4 Rear I/O Ports	98
COM Port	98
LAN Ports (LAN1, LAN2, and BMC LAN)	99
USB Ports	99
VGA Port	99
Unit Identifier/BMC Reset Switch	99
4.5 Jumper Settings	101
CMOS Clear	101
LAN Ports Enable/Disable	102
4.6 LED Indicators	103
BMC Heartbeat LED	103
BMC LAN LEDs	103
LAN LEDs	103
M.2 LEDs	104
Onboard Power LED	104
Unit ID (UID) LED	104

4.1 Power Supply and Power Connections

For information about the power supply and power connections of the SYS-622B-TRT server, refer to the following content.

ATX Power Connectors

The primary 24-pin power supply connection (JPWR3 on the X14DBI-T motherboard) meets the ATX SSI EPS 12 V specification. JPWR1, JPWR2 and JPWR4 are 8-pin +12 V DC power inputs for the processors that must be connected to the power supply.

Important: To provide adequate power supply to the motherboard, be sure to connect the 24-pin ATX PWR and the 8-pin PWR connections to the power supply. Failure to do so may void the manufacturer warranty on your power supply and motherboard.

For a detailed diagram of the X14DBI-T motherboard, see the layout under "[Motherboard Quick Reference](#)" on page 23.

8-pin CPU Power Pin Definitions: Eight Total	
Pin#	Definition
1-4	GND
5-8	+12 V (12 V Power)

ATX Power 24-pin Connection Pin Definitions: 24 Total			
Pin#	Definition	Pin#	Definition
13	+3.3 V	1	+3.3 V
14	No Connection	2	+3.3 V
15	GND	3	GND
16	PS_ON	4	+5 V
17	GND	5	GND
18	GND	6	+5 V
19	GND	7	GND
20	Res (No Connection)	8	PWR_OK
21	+5 V	9	+5 VSB
22	+5 V	10	+12 V
23	+5 V	11	+12 V
24	GND	12	+3.3 V

4.2 Headers and Connections

For information about the headers on the X14DBI-T motherboard, refer to the following content.

Backplane SMBus Header

One backplane SMBus (I²C) header is located at JBPNI2C1 on X14DBI-T motherboard. It is used to connect SMBus devices to the system backplane components.

For a detailed diagram of the X14DBI-T motherboard, see the layout under "[Motherboard Quick Reference](#)" on page 23.

Backplane SMBus Header	
Pin Definitions: Four Total	
Pin#	Definition
1	Data
2	GND
3	Clock
4	VCCIO

Chassis Intrusion

A Chassis Intrusion header is located at JL1 on the X14DBI-T motherboard. Attach the appropriate cable from the chassis to inform you when the chassis is opened.

For a detailed diagram of the X14DBI-T motherboard, see the layout under "[Motherboard Quick Reference](#)" on page 23.

Chassis Intrusion	
Pin Definitions: Two Total	
Pin#	Definition
1	Intrusion Input
2	GND

COM Header

There is one COM header at COM2 on the X14DBI-T motherboard. Use a cable with the COM header to access the COM2 COM port. COM ports provide serial communication support.

For a detailed diagram of the X14DBI-T motherboard, see the layout under "[Motherboard Quick Reference](#)" on page 23.

COM Header			
Pin Definitions: Nine Total			
Pin#	Definition	Pin#	Definition
1	SP_DCD0	6	SP_DSR0
2	SP_RXD0	7	SP_RTS0
3	SP_TXD0	8	SP_CTS0
4	SP_DTR0	9	SP_RI0
5	GND		

External BMC I²C Header

A System Management Bus header for the BMC is located at JIPMB1 on the X14DBI-T motherboard. Connect the appropriate cable here to use the IPMB I²C connection on your system.

For a detailed diagram of the X14DBI-T motherboard, see the layout under "[Motherboard Quick Reference](#)" on page 23.

Fan Headers

There are eight 4-pin fan headers (FAN1–FAN6, FANA, and FANB) on the X14DBI-T motherboard. All these 4-pin fan headers are backwards compatible with the traditional 3-pin fans. However, fan speed control is available for 4-pin fans only by Thermal Management via the BMC interface.

For a detailed diagram of the X14DBI-T motherboard, see the layout under "[Motherboard Quick Reference](#)" on page 23.

4-pin Fan Header	
Pin Definitions: Four Total	
Pin#	Definition
1	GND (Black)
2	+12 V (Red)
3	Tachometer
4	PWM Control

M.2 M-Key PCIe 5.0 x4 Slots

Two M.2 M-key slots are located at M.2-C1 and M.2-C2 on the X14DBI-T motherboard. The M.2 M-key slots on the motherboard support PCIe 5.0 x4 devices in a 2280/22110 form factor.

For a detailed diagram of the X14DBI-T motherboard, see the layout under "[Motherboard Quick Reference](#)" on page 23.

MCIO PCIe 5.0 x8 Connectors

Mini Cool Edge IO (MCIO) PCIe 5.0 x8 connectors are located at P1_NVME0/1, P1_NVME2/3 and P2_NVME4/5 on the X14DBI-T motherboard. P1_NVME0/1 and P1_NVME2/3 connections are supported by CPU1, and P2_NVME4/5 is supported by CPU2. Each MCIO connector supports two PCIe 5.0 x4 connections. Use these MCIO connectors to connect high-speed PCIe NVMe storage devices.

Note: When installing an NVMe device on a motherboard, please be sure to connect the first NVMe port (P1_NVME0/1) first for your system to work properly.

For a detailed diagram of the X14DBI-T motherboard, see the layout under "[Motherboard Quick Reference](#)" on page 23.

NC-SI Connection

The Network Controller Sideband Interface (NC-SI) connection is located at JNCSI1 on the X14DBI-T motherboard. This connection is used to connect a Network Interface Card (NIC) to the motherboard to allow the onboard Baseboard Management Controller (BMC) to communicate with a network.

Note: For detailed instructions on how to configure Network Interface Card (NIC) settings, refer to the Network Interface Card Configuration User's Guide posted on the web page under the link: <https://www.supermicro.com/support/manuals>.

For a detailed diagram of the X14DBI-T motherboard, see the layout under "[Motherboard Quick Reference](#)" on page 23.

NVMe SMBus Header

An NVMe SMBus (I²C) header is located at JNVI²C1 on the X14DBI-T motherboard. It is used for PCIe SMBus clock and data connections, provides hot-plug support through a dedicated SMBus interface. This feature is only available for a Supermicro complete system with a Supermicro proprietary NVMe add-on card and a proper cable installed.

For a detailed diagram of the X14DBI-T motherboard, see the layout under ["Motherboard Quick Reference"](#) on page 23.

NVMe SMBus Header	
Pin Definitions: Four Total	
Pin#	Definition
1	Data
2	GND
3	Clock
4	VCCIO

Power SMB (I²C) Header

The Power System Management Bus (I²C) connector (JPI²C1 on the X14DBI-T motherboard) monitors the power supply, fan, and system temperatures.

For a detailed diagram of the X14DBI-T motherboard, see the layout under ["Motherboard Quick Reference"](#) on page 23.

Power SMBus Header	
Pin Definitions: Five Total	
Pin#	Definition
1	Clock
2	Data
3	PMBUS_Alert
4	GND
5	+3.3 V

SATA Ports

The X14DBI-T motherboard has two SATA 3.0 ports (SATA0 and SATA1) and one slim SAS x8 connector (JS1 for SATA 2–9) for connecting SATA devices. All the SATA ports and the slim SAS connector are supported by SATA controllers. Connect proper SATA cables to use the connections.

For a detailed diagram of the X14DBI-T motherboard, see the layout under ["Motherboard Quick Reference"](#) on page 23.

Standby Power

The Standby Power header is located at JSTBY1 on the motherboard. You must have a card with a Standby Power connector and a cable to use this feature.

For a detailed diagram of the X14DBI-T motherboard, see the layout under "[Motherboard Quick Reference](#)" on page 23.

Standby Power	
Pin Definitions: Three Total	
Pin#	Definition
1	+5 V Standby
2	GND
3	No Connection

TPM/Port 80 Header

The JTPM1 header on the X14DBI-T motherboard is used to connect a Trusted Platform Module (TPM)/Port 80, which is available from Supermicro (optional). A TPM/Port 80 connector is a security device that supports encryption and authentication in storage drives. It allows the motherboard to deny access if the TPM associated with the storage drive is not installed in the system. Information on the TPM is available at the following page:

https://www.supermicro.com/manuals/other/AOM-TPM-9670V_9670H_X12_H12.pdf

For a detailed diagram of the X14DBI-T motherboard, see the layout under "[Motherboard Quick Reference](#)" on page 23.

Trusted Platform Module Header			
Pin Definitions: 10 Total			
Pin#	Definition	Pin#	Definition
1	+3.3 V	2	SPI_CS#
3	RESET#	4	SPI_MISO
5	SPI_CLK	6	Ground
7	SPI_MOSI	8	No Connection
9	+1.8 V Standby	10	SPI_IRQ#

USB Header

There is one USB 3.0 (USB 3.2 Gen1) header (USB4/5) on the X14DBI-T motherboard. The USB header supports two USB connections for front access using USB cables (not included).

For a detailed diagram of the X14DBI-T motherboard, see the layout under "[Motherboard Quick Reference](#)" on page 23.

(USB 3.0) Header			
Pin Definitions: 20 Total			
Pin#	Definition	Pin#	Definition
1	+5 V	20	No Connection
2	Stda_SSRX-	19	+5 V
3	Stda_SSRX+	18	Stda_SSRX-
4	GND	17	Stda_SSRX+
5	Stda_SSTX-	16	GND
6	Stda_SSTX+	15	Stda_SSTX-
7	GND	14	Stda_SSTX+
8	USB2_N	13	GND
9	USB2_P	12	USB2_N
10	GND	11	USB2_P

VGA Header

In addition to the VGA port on the rear I/O, there is a front accessible VGA header located at JFP2 on the X14DBI-T motherboard. These VGA connections provide analog interface support between the computer and the video displays.

For a detailed diagram of the X14DBI-T motherboard, see the layout under "[Motherboard Quick Reference](#)" on page 23.

VROC RAID Key Header

A VROC RAID Key header is located at JRK1 on the X14DBI-T motherboard. Install a VROC RAID key on JRK1 for NVMe RAID support as shown in the illustration below.

For a detailed diagram of the X14DBI-T motherboard, see the layout under "[Motherboard Quick Reference](#)" on page 23.

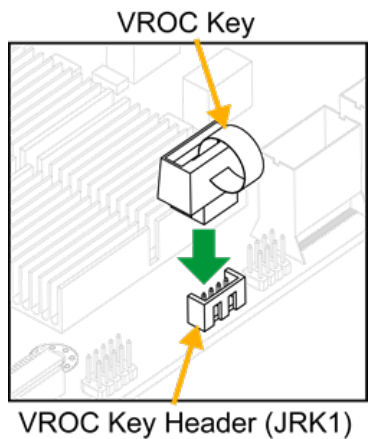

Intel VROC Key Pin Definitions: Four Total	
Pin#	Definition
1	GND
2	+3.3 V Standby
3	GND
4	CPU RAID Key

Note: Images displayed are for illustrative purposes only. The components installed in your system may or may not look exactly the same as the graphics shown in the manual.

Note: For detailed instructions on how to configure VROC RAID settings, refer to the VROC RAID Configuration User's Guide posted on the web page under the following link: <https://www.supermicro.com/support/manuals>.

4.3 Front Control Panel Header

JF1 on the X14DBI-T motherboard contains header pins for various buttons and indicators that are normally located on a control panel at the front of the chassis. These connectors are designed specifically for use with Supermicro chassis.

For a detailed diagram of the X14DBI-T motherboard, see the layout under "[Motherboard Quick Reference](#)" on page 23.

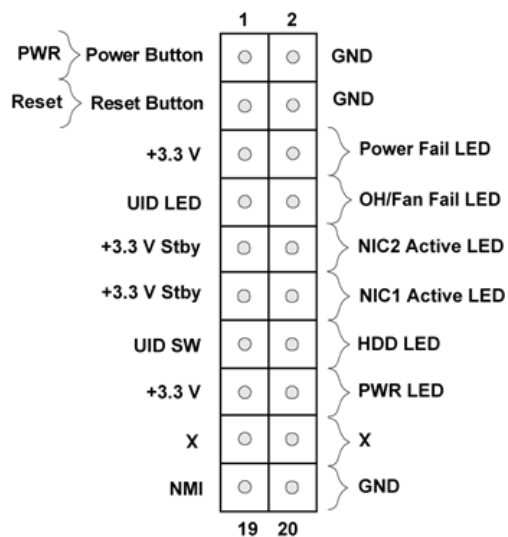

Figure 4-1. JF1 Header Pins

Power On and BMC/BIOS Status LED Button

The Power On and BMC/BIOS Status LED button is located on pin 1 of the front control panel header (JF1) on the X14DBI-T motherboard. Momentarily contacting pin 1 of JF1 will power on/off the system or display BMC/BIOS status.

For a detailed diagram of the X14DBI-T motherboard, see the layout under "[Motherboard Quick Reference](#)" on page 23.

Power On & BIOS/BMC Status LED Button	
Pin Definitions (JF1)	
Pin#	Definition
1	Signal
2	GND

Power On and BMC/BIOS Status LED Indicator Status	
Status	Event
Green: Solid on	System power on
BMC/BIOS blinking green at 4 Hz	BMC/BIOS checking
BIOS blinking green at 4 Hz	BIOS recovery/update in progress
BMC blinking red x2 (2 blinks red) at 4 Hz, 1 pause at 2 Hz (on-on-off-off)	BMC recovery/update in progress
BMC/BIOS blinking green at 1 Hz	Flash not detected or golden image checking failure

Reset Button

The Reset Button connection is located on pins 3 and 4 of JF1 on the X14DBI-T motherboard. Attach it to a hardware reset switch on the computer case to reset the system.

For a detailed diagram of the X14DBI-T motherboard, see the layout under "[Motherboard Quick Reference](#)" on page 23.

Reset Button	
Pin Definitions (JF1)	
Pin#	Definition
3	Reset
4	GND

Power Fail LED

The Power Fail LED connection is located on pins 5 and 6 of JF1 on the X14DBI-T motherboard.

For a detailed diagram of the X14DBI-T motherboard, see the layout under "[Motherboard Quick Reference](#)" on page 23.

Power Fail LED	
Pin Definitions (JF1)	
Pin#	Definition
5	+3.3 V
6	PWR Supply Fail

Overheat/Fan Fail and UID LED

Connect an LED cable to pins 7 and 8 of the Front Control Panel to use the Overheat/Fan Fail LED connections. The LED on pin 8 provides warnings of overheat or fan failure.

For a detailed diagram of the X14DBI-T motherboard, see the layout under "[Motherboard Quick Reference](#)" on page 23.

OH/Fan Fail Indicator Status Pin Definitions (JF1)		OH/Fan Fail/UID LED Pin Definitions (JF1)	
State	Definition	Pin#	Definition
Off	Normal	7	UID LED (Blue)
On	Overheat	8	OH/FAN Fail LED
Flashing	Fan Fail		

Fail LED (Information LED) (OH/Fan Fail/PWR Fail) LED States	
Status	Description
Solid red (on)	An overheating has occurred.
Blinking red (1 Hz)	Fan failure: check for an inoperative fan.
Blinking red (0.25 Hz)	Power failure: check for a non-operational power supply
Blinking red (10 Hz) (FP red LED)	CPLD recovery mode error(s)
Solid blue	UID has been activated locally. Use this function to locate a unit in the system that might be in need of service.
Blinking blue (1 Hz)	Local UID has been activated locally on. Use this function to identify a unit that might be in need of service.
BIOS/BMC blinking blue (10 Hz)	BIOS/BMC: recovery and/or update in progress
Red Info LED blinking (10 Hz) and MB UID LED blue blinking (10 Hz)	CPLD: recovery and/or update in progress

NIC1/NIC2 (LAN1/LAN2)

The Network Interface Controller (NIC) LED connection for LAN port 1 is located on pins 11 and 12 of JF1 on the X14DBI-T motherboard, and LAN port 2 is on pins 9 and 10. Attach the NIC LED cables here to display network activity.

For a detailed diagram of the X14DBI-T motherboard, see the layout under "[Motherboard Quick Reference](#)" on page 23.

LAN1/LAN2 LED	
Pin Definitions (JF1)	
Pin#	Definition
9	VCC
10	NIC2 Link/Active LED
11	VCC
12	NIC1 Link/Active LED

HDD LED/UID Switch

The HDD LED/UID Switch connection is located on pins 13 and 14 of JF1 on the X14DBI-T motherboard. Attach a cable to pin 14 to show storage drive activity status. Attach a cable to pin 13 to use the UID button.

For a detailed diagram of the X14DBI-T motherboard, see the layout under ["Motherboard Quick Reference"](#) on page 23.

HDD LED/UID Switch	
Pin Definitions (JF1)	
Pin#	Definition
13	+3.3 V Stdby/UID Switch
14	HDD Activity

HDD LED Status	
Pin Definitions (JF1)	
Color	State
Blinking Green	HDD Active

Power LED

The Power LED connection is located on pins 15 and 16 of JF1 on the X14DBI-T motherboard.

For a detailed diagram of the X14DBI-T motherboard, see the layout under ["Motherboard Quick Reference"](#) on page 23.

Power LED	
Pin Definitions (JF1)	
Pin#	Definition
15	+3.3 V
16	PWR LED

NMI Button

The non-maskable interrupt (NMI) button header is located on pins 19 and 20 of JF1 on the X14DBI-T motherboard.

For a detailed diagram of the X14DBI-T motherboard, see the layout under "[Motherboard Quick Reference](#)" on page 23.

NMI Button	
Pin Definitions (JF1)	
Pin#	Definition
19	Control
20	GND

4.4 Rear I/O Ports

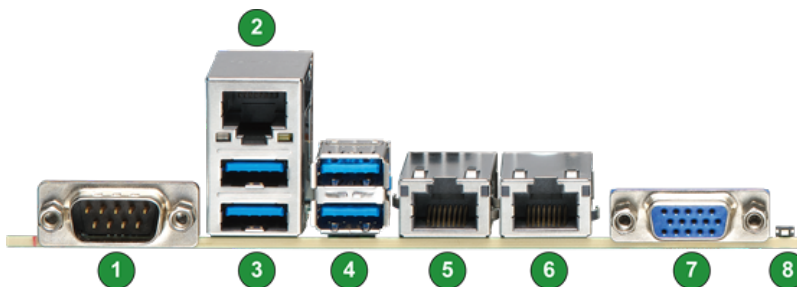

Figure 4-2. X14DBI-T Rear I/O Ports

Rear I/O Ports			
#	Description	#	Description
1	COM Port (COM1)	5	10 GbE for X14DBI-T
2	Dedicated BMC LAN	6	10 GbE for X14DBI-T
3	USB0/1 (3.0)	7	VGA Port
4	USB2/3 (3.0)	8	UID/BMC Reset Switch

COM Port

There is one COM port (COM1) on the I/O ports of the motherboard. The COM port provides serial communication support.

For a detailed diagram of the X14DBI-T motherboard, see the layout under ["Motherboard Quick Reference"](#) on page 23.

COM Port			
Pin Definitions: 11 Total			
Pin#	Definition	Pin#	Definition
1	SP_DCD0	6	SP_DSR0
2	SP_RXD0	7	SP_RTS0
3	SP_TXD0	8	SP_CTS0
4	SP_DTR0	9	SP_RI0
5	GND	10	GND
		11	GND

LAN Ports (LAN1, LAN2, and BMC LAN)

There are two RJ45 LAN ports (LAN1 and LAN2) and one BMC dedicated LAN port (BMC_LAN) on the rear I/O of the motherboard. LAN1/LAN2 on the X14DBI-T motherboard supports 10 GbE network connections via the Broadcom 57416 LAN controller. The dedicated BMC LAN, located above the USB0/1 ports on the rear I/O, provides LAN support for the BMC (Baseboard Management Controller). All of these LAN ports accept RJ45 cables.

Refer to the LED Indicator section for LAN LED information.

USB Ports

There are four USB 3.0 ports (USB0/1 and USB2/3) on the rear I/O of the X14DBI-T motherboard.

There is also one USB 3.0 header (USB4/5) located on the the X14DBI-T motherboard. Refer to the ["USB Header" on page 91](#) section for details.

VGA Port

A video (VGA) port is located on the I/O ports of the motherboard. The VGA port provides analog interface support between the computer and the video displays.

For a detailed diagram of the X14DBI-T motherboard, see the layout under ["Motherboard Quick Reference" on page 23](#).

Unit Identifier/BMC Reset Switch

A UID LED/BMC Reset switch (JUIDB1) is located on the rear side of the X14DBI-T. This switch has dual functions. It can be used to identify a system unit that is in need of service, and it can also be used to reset the BMC settings.

For a detailed diagram of the X14DBI-T motherboard, see the layout under ["Motherboard Quick Reference" on page 23](#).

Function	User Input	Behavior	LED Activity
UID LED Indicator	Push Once	Turns on the UID LED	UID LED turns solid blue
	Push Again	Turns off the UID LED	UID LED turns off
BMC Reset	Push and hold for 6 seconds Push and hold for 12 seconds	BMC will do a cold boot BMC will reset to factory default	BMC Heartbeat LED turns solid green BMC Heartbeat LED turns solid green

Note: After pushing and holding the UID button for 12 seconds, all BMC settings including username and password will revert back to the factory default. Only the network settings and FRU are retained.

UID Button	
Pin Definitions: Four Total	
Pin#	Definition
1	Button In
2	GND
G1	GND
G2	GND

UID LED	
Pin Definitions: Four Total	
Color	Status
1	Button In
2	GND
G1	GND
G2	GND

4.5 Jumper Settings

To modify the operation of the motherboard, jumpers can be used to choose between optional settings. Jumpers create shorts between two pins to change the function of the connector. Pin 1 is identified with a square solder pad on the printed circuit board. See the diagram below for an example of jumping pins 1 and 2. Refer to the motherboard layout page for jumper locations.

Note: On two-pin jumpers, "Closed" means the jumper is on and "Open" means the jumper is off the pins.

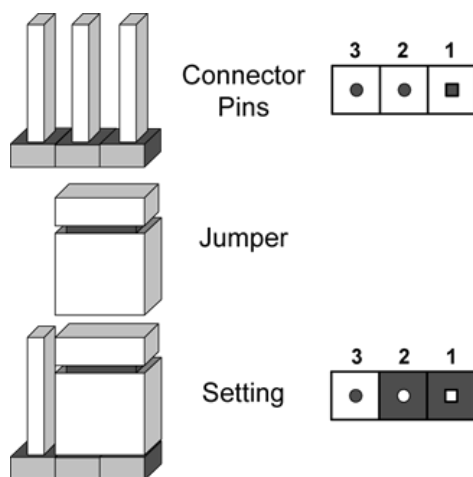

Figure 4-3. Jumping Connector Pins

CMOS Clear

JBT1 on the X14DBI-T motherboard is used to clear CMOS, which will also clear any passwords. Instead of pins, this jumper consists of contact pads to prevent accidentally clearing the contents of CMOS.

For a detailed diagram of the X14DBI-T motherboard, see the layout under ["Motherboard Quick Reference"](#) on page 23.



1. First power down the system and unplug the power cord(s).
2. Remove the cover of the chassis to access the motherboard.
3. Remove the onboard battery from the motherboard.

4. Short the CMOS pads, JBT1, with a metal object such as a small screwdriver for at least four seconds.

Note: Clearing CMOS will also clear all passwords.

5. Remove the screwdriver (or shorting device).
6. Replace the cover, reconnect the power cord(s), and power on the system.

LAN Ports Enable/Disable

Use JPL1 to enable or disable LAN1 and LAN2 on the X14DBI-T. The default setting is Enabled.

LAN Enable/Disable Jumper Settings	
Jumper Setting	Definition
Pins 1–2	Enabled (Default)
Pins 2–3	Disabled

4.6 LED Indicators

For information about the LED indicators on the SYS-622B-TRT server, refer to the following content.

BMC Heartbeat LED

A BMC Heartbeat LED is located at LEDBMC on the X14DBI-T motherboard. When this LED is blinking, the BMC is functioning normally.

For a detailed diagram of the X14DBI-T motherboard, see the layout under "[Motherboard Quick Reference](#)" on page 23.

BMC Heartbeat LED Indicator	
LED Color	Definition
Green: Blinking	BMC Normal

BMC LAN LEDs

The dedicated BMC LAN connection on the X14DBI-T motherboard features two LEDs. The LED on the right indicates activity, and the LED on the left indicates the speed of the connection.

For a detailed diagram of the X14DBI-T motherboard, see the layout under "[Motherboard Quick Reference](#)" on page 23.

BMC LAN LEDs		
	Color/State	Definition
Link (left)	Green: Solid	100 Mbps
	Amber: Solid	1 Gbps
Activity (right)	Amber: Blinking	Active

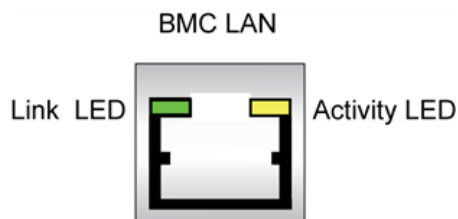

LAN LEDs

Each LAN port of the X14DBI-T motherboard has two LEDs. The green LED indicates activity, while the other Link LED may be yellow, amber, or off to indicate the speed of the connection.

For a detailed diagram of the X14DBI-T motherboard, see the layout under "[Motherboard Quick Reference](#)" on page 23.

LAN Link LED (Left) LED State		LAN Activity LED (Right) LED State	
LED Color	Definition	LED Color	Definition
Green: Solid	10 Gbps	Yellow: Flashing	Active
Yellow/Amber: Solid	1 Gbps		

M.2 LEDs

M.2 LEDs are located at LED4 and LED7 on the X14DBI-T motherboard. When these LEDs are blinking, the M.2 devices are functioning normally.

For a detailed diagram of the X14DBI-T motherboard, see the layout under "[Motherboard Quick Reference](#)" on page 23.

M.2 LED State	
LED Color	Definition
Green: Blinking	Device Working

Onboard Power LED

For a detailed diagram of the X14DBI-T motherboard, see the layout under "[Motherboard Quick Reference](#)" on page 23.

Onboard Power LED Indicator	
LED Color	Definition
Off	System Power Off (power cable not connected)
Green	System Power On

Unit ID (UID) LED

The UID LED indicator is located at LED6 on the X14DBI-T motherboard. This UID indicator provides easy identification of a system that may need to be serviced.

For a detailed diagram of the X14DBI-T motherboard, see the layout under "[Motherboard Quick Reference](#)" on page 23.

UID LED LED Indicator	
LED Color	Definitions
Blue: On	System Identified

Chapter 5:

Software

After the SYS-622B-TRT server has been installed, you can install the Operating System (OS), configure RAID settings, and install the drivers.

5.1 Microsoft Windows OS Installation	106
Installing the OS	106
5.2 Driver Installation	108
5.3 BMC	110
BMC ADMIN User Password	110

5.1 Microsoft Windows OS Installation

If you will be using RAID, you must configure RAID settings before installing the Windows OS and the RAID driver. Refer to the RAID Configuration User Guides posted on our website at <https://www.supermicro.com/support/manuals>.

Installing the OS

1. Create a method to access the Microsoft Windows installation ISO file. That can be a USB flash or media drive, or the BMC KVM console.
2. Retrieve the proper drivers. Go to the Supermicro web page for your motherboard and click on "Download the Latest Drivers and Utilities," select the proper driver, and copy it to a USB flash drive.
3. Boot from a bootable device with Windows OS installation. You can see a bootable device list by pressing <F11> during the system bootup.

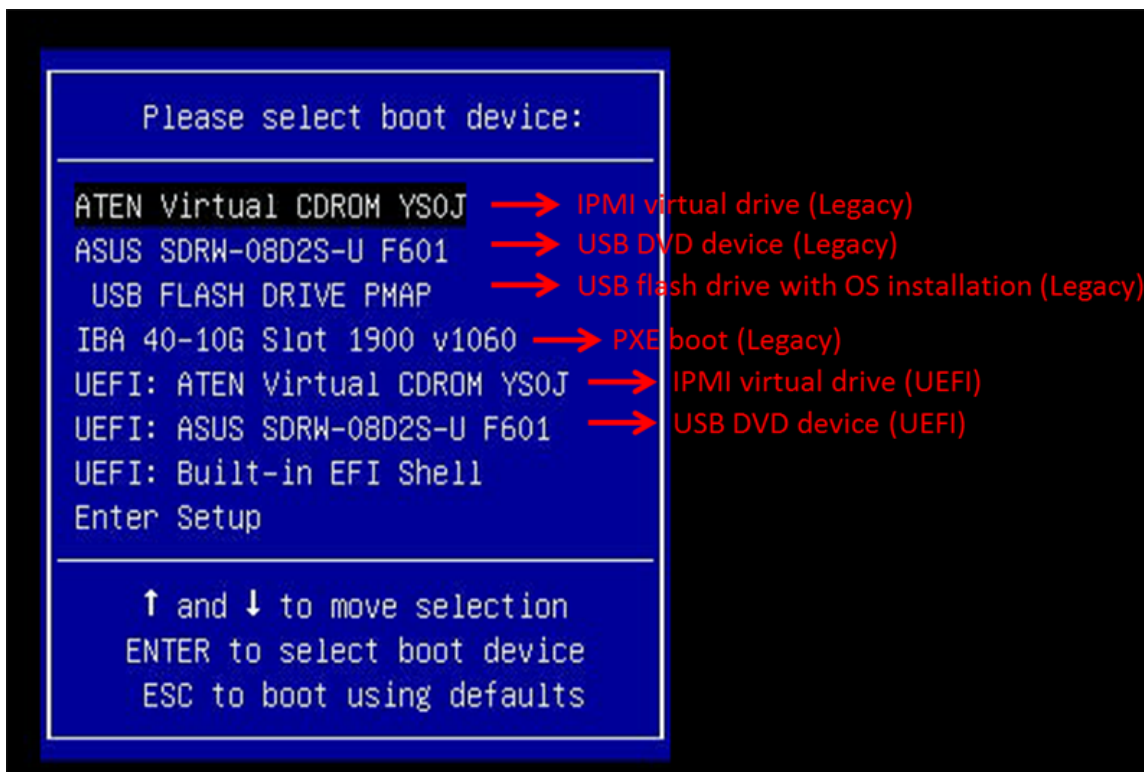

Figure 5-1. Selecting the Boot Device

4. During Windows Setup, continue to the dialog box where you select the drives on which to install Windows. If the disk you want to use is not listed, click on the "Load driver" link at the bottom left corner.

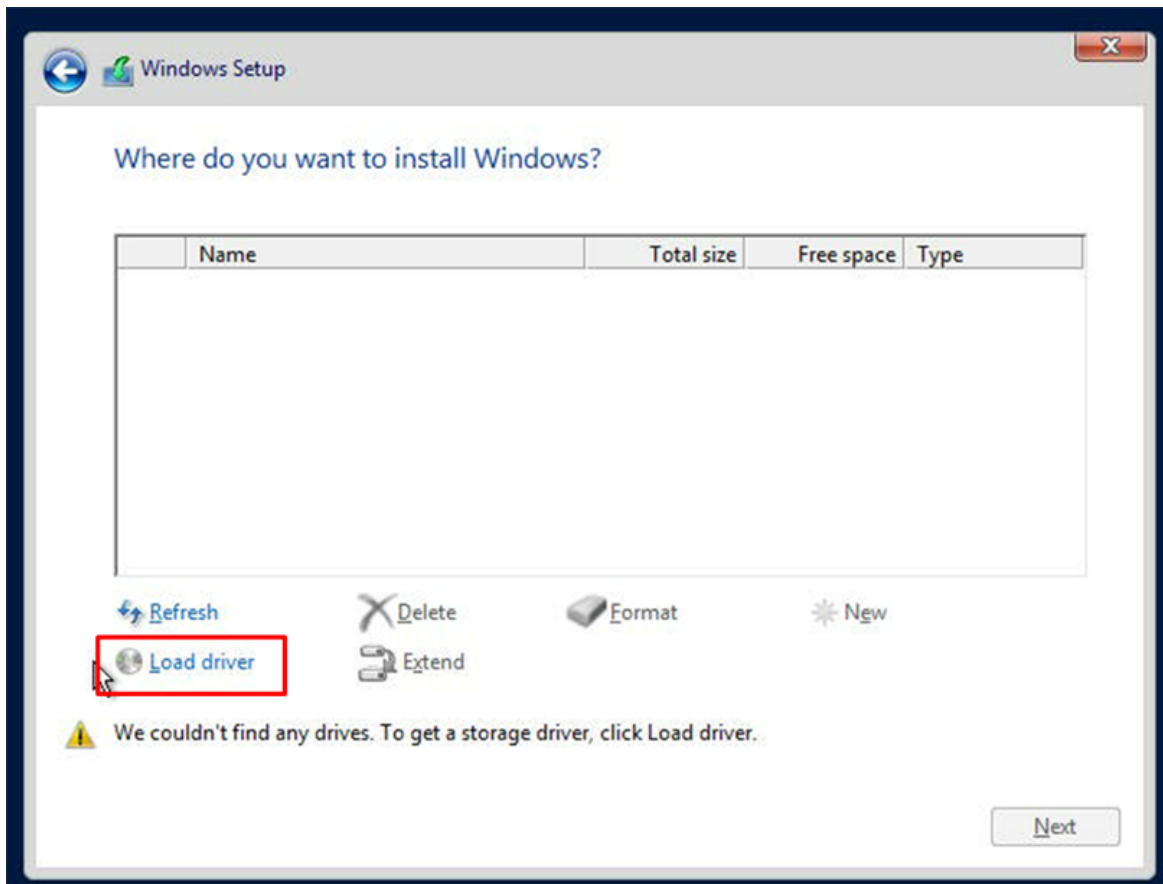

Figure 5-2. Loading the Driver Link

To load the driver, browse the USB flash drive for the proper driver files.

5. Once all devices are specified, continue with the installation.
6. After the Windows OS installation has completed, the system will automatically reboot multiple times for system updates.

5.2 Driver Installation

The Supermicro website contains drivers and utilities for your system at the following page:

<https://www.supermicro.com/wdl>.

Some of these drivers and utilities must be installed, such as the chipset driver. After accessing the website, go into the CDR_Images (in the parent directory of the above link) and locate the ISO file for your motherboard. Download this file to a USB flash or media drive. You may also use a utility to extract the ISO file if preferred.

Another option is to go to the Supermicro website at <https://www.supermicro.com>. Find the product page for your motherboard and download the latest drivers and utilities. Insert the flash drive or disk, and the screenshot shown below should appear.

Note: Click the icons showing a hand writing on paper to view the readme files for each item. Click the computer icons to the right of these items to install each item (from top to bottom) one at a time. After installing each item, you must reboot the system before moving on to the next item on the list. The bottom icon with a CD on it allows you to view the entire contents.

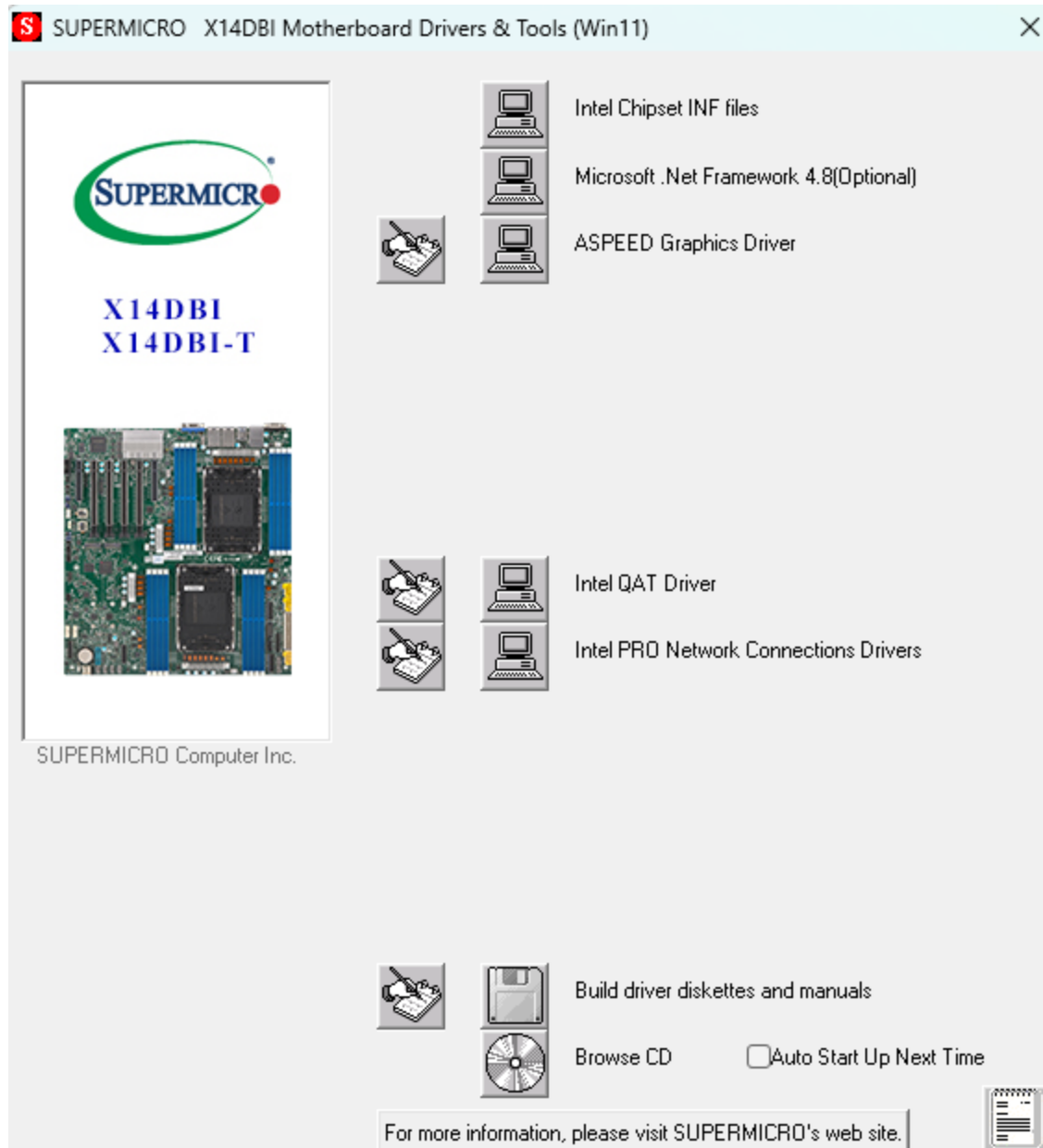

Figure 5-3. Driver Installation

5.3 BMC

The X14DBI-T motherboard provides remote access, monitoring, and management through the baseboard management controller (BMC) and other management controllers distributed among different system modules. There are several BIOS settings that are related to BMC. For general documentation and information on BMC, visit our website at the following page:

<https://www.supermicro.com/en/solutions/management-software/bmc-resources>

BMC ADMIN User Password

For security, each system is assigned a unique default BMC password for the ADMIN user. The password can be found on a sticker on the motherboard and a sticker on the chassis, for Supermicro chassis. The sticker also displays the BMC MAC address. If necessary, the password can be reset using the Supermicro IPMICFG tool.



Figure 5-4. BMC Password Label

Chapter 6:

Optional Components

This chapter describes alternate configurations and optional system components for the SYS-622B-TRT server.

6.1 TPM Security Module	112
6.2 HBA Card	113
6.3 RAID Cards	114
6.4 Cable Management Arm	115
Installing the Cable Management Arm	116
Removing the Cable Management Arm	117
6.5 Intel Virtual RAID on CPU (VROC)	118
Requirements and Restrictions	118
Additional Information	118
Hardware Key	119
Configuring Intel VMD	120
Creating NVMe RAID Configurations	125

6.1 TPM Security Module

This is an SPI-capable TPM 2.0 with Infineon 9672 controller.

The JTPM1 header is used to connect a Trusted Platform Module (TPM). A TPM is a security device that supports encryption and authentication in hard drives. It enables the X14DBI-T motherboard to deny access if the TPM associated with the hard drive is not installed in the SYS-622B-TRT server.

For details and installation procedures, refer to the following page:

<https://www.supermicro.com/en/products/accessories/addon/AOM-TPM-9672V.php>

- AOM-TPM-9672V (TCG 2.0)

6.2 HBA Card

This is a 12 Gb/s, multi-port SAS PCIe Gen 4.0 internal Host Bus Adapter (HBA) card.

The Supermicro HBA AOC-S3816L-L16iT features 16 internal SAS connectors, while the AOC-S3808L-L8iT features eight internal SAS connectors. Both are designed for high-performance storage connectivity.

These cards use Broadcom's 3816 and 3808 I/O processors for optimum performance with PCI Express Gen 4.0 host interface for increased bandwidth.

Each Add-On-Card supports up to 122 devices as HBA in IT mode via the expander backplane.

6.3 RAID Cards

These are Super Micro Computer, Inc. 12 Gb/s, multi-port PCIe Gen 4.0 RAID adapter cards.

The low-profile AOC-S3908L-H8iR RAID card features eight internal SAS connectors and the AOC-S3916L-H16iR features 16 internal SAS connectors. Both offer high-performance storage connectivity. These RAID cards are built on the Broadcom SAS IC technology and MegaRAID technology to address the growing demand for increased data throughput and scalability requirements across the enterprise-class server platforms.

With high-performance RAID architecture, including hardware RAID 5 and 6, these RAID controller cards support high capacity storage applications. They deliver cost-effective storage solutions using SATA drives and maximum performance and reliability with SAS drives. Using expander backplanes, they support up to 16, 32, and 240 drives (depending on SKU) with RAID 0, 1, 5, 6, 10, 50, and 60.

6.4 Cable Management Arm

The SYS-622B-TRT server supports a cable management arm (CMA), which keeps the rear cables organized and clear of the rail mechanisms when the system is extended out the front of the rack for maintenance.

The CMA attaches to the rack mounting rails using four connectors. They are labeled as connectors 1, 2, 3, and 4.

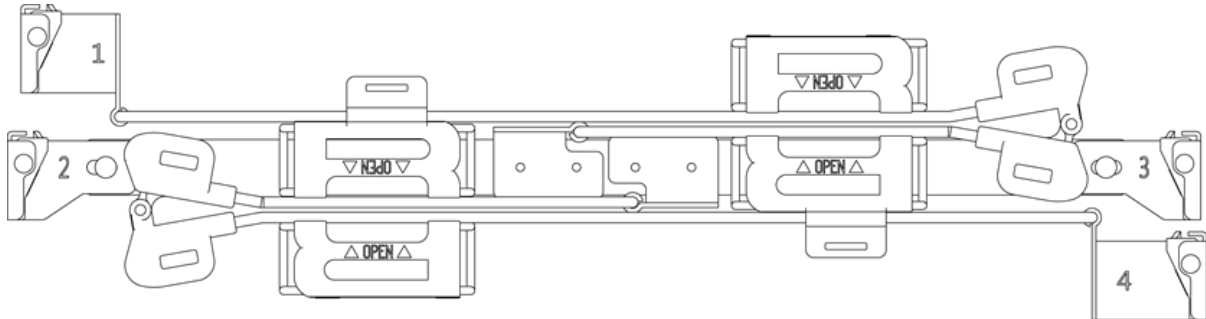

Figure 6-1. Cable Management Arm

Cable Arm Details		
Optional Part	Part Number	Description
Cable Management Arm	MCP-290-00073-0N	Supermicro Cable Management Arm for 2U, 3U and 4U chassis
Cable Arm Adapter	MCP-120-82503-0N	Cable arm adapter for SC825, 213, 829H, 847B

Installing the Cable Management Arm

1. Slide CMA connector #1 forward onto the two posts on the rear of the right inner rail (right side when viewed from the front). The connector will snap into place.
2. Slide CMA connector #2 forward onto the two posts on the rear of the right middle rail until it snaps into place.

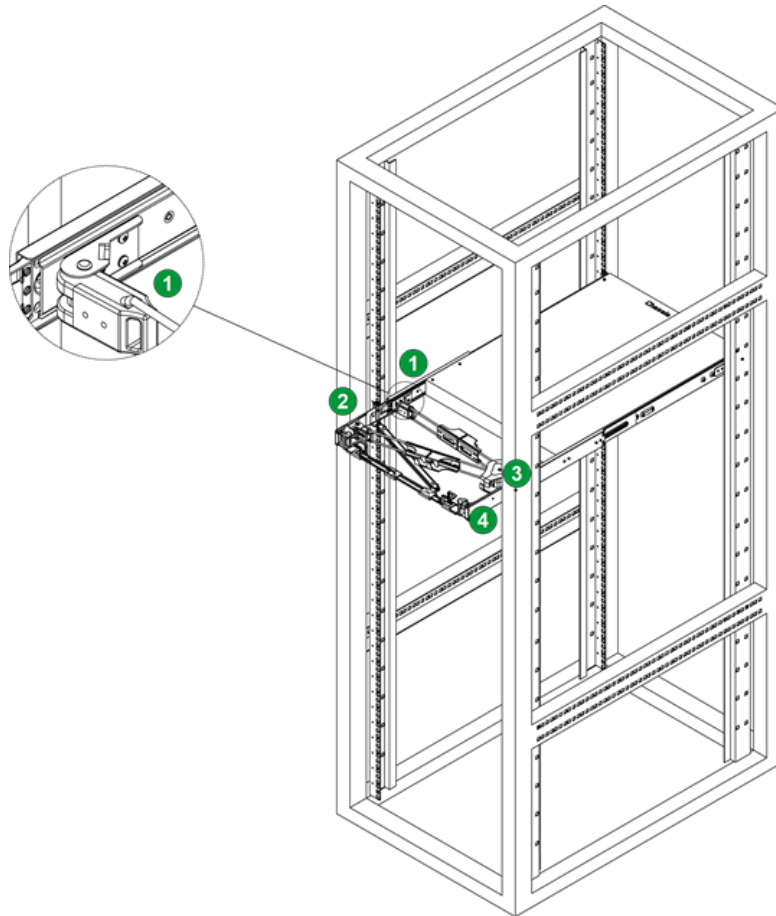

Figure 6-2. Installing the Connectors

3. Slide CMA connector #3 forward onto the two posts on the rear of the left middle rail until it snaps into place.
4. For CMA connector #4, align the metal tabs with the slots on the rear of the left outer rail and push it forward until it snaps into place.
5. Route the cables through the holding brackets. The cables should have slack once they're in place.

Removing the Cable Management Arm

1. Remove cables from the CMA.
2. For CMA connector #4, pull the metal release tab toward the center of the rack and slide the connector toward the rear to release it.
3. For CMA connectors #3, #2, and #1, depress the front edge of the yellow plastic rocker lock and slide the connector toward the rear to release it.

6.5 Intel Virtual RAID on CPU (VROC)

Intel® Virtual RAID on CPU (Intel VROC) is an enterprise RAID solution for NVMe SSDs directly attached to Intel Xeon Scalable processors. Intel Volume Management Device (VMD) is an integrated controller inside the CPU PCIe root complex.

- A single processor supports up to 12 NVMe SSDs and up to 6 RAID arrays.
- A dual processor system supports up to 24 NVMe SSDs and 12 RAID arrays.

Stripe sizes are 4K, 8K, 16K, 32K, 64K, 128K.

Requirements and Restrictions

- *Intel VROC is only available when the system is configured for UEFI boot mode.*
- To enable the **mdadm** command and support for RSTe, install the patch from
 - Linux: <https://downloadcenter.intel.com/download/28158/Intel-Virtual-RAID-on-CPU-Intel-VROC-and-Intel-Rapid-Storage-Technology-enterprise-Intel-RSTe-Driver-for-Linux->
 - Windows: <https://downloadcenter.intel.com/download/28108/Intel-Virtual-RAID-on-CPU-Intel-VROC-and-Intel-Rapid-Storage-Technology-enterprise-Intel-RSTe-Driver-for-Windows->
- To enable Intel VROC, a hardware key must be inserted on the motherboard, and the appropriate processor's Virtual Management Devices must be enabled in the BIOS setup.
- It is possible to enable Intel VROC without a hardware key installed, but only RAID0 will be enabled.
- Intel VROC is not compatible with secure boot. This feature must be disabled.
- When creating bootable OS RAID1 devices, you must have both devices on the same CPU, and a VMD on that CPU.
- Spanning drives when creating RAID devices is not recommended due to performance issues, even though it is supported.

Additional Information

- Latest SSD and operating system information:
<https://www.intel.com/content/www/us/en/support/articles/000030310/memory-and-storage/ssd-software.html>

- Additional information for the Supermicro add-on card and linked manuals:
<https://www.supermicro.com/products/accessories/addon/AOC-VROCxxxMOD.cfm>

Hardware Key

The Intel VROC hardware key is a license key that detects the Intel VROC SKU and activates the function accordingly. The key must be plugged into the Supermicro motherboard (connector JRK1). The key options are:

Intel® VROC Keys			
VROC Package	Description	Part Number	Intel MM Number
Standard	RAID 0, 1, 10 Supports 3rd party SSDs	AOC-VROCSTNMOD	951605
Premium	RAID 0, 1, 5, 10 Supports 3rd party SSDs	AOC-VROCPREMOD	951606

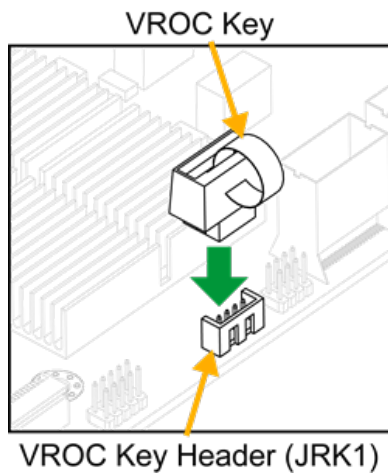

Figure 6-3. Intel VROC RAID Key and Motherboard Connector JRK1

Configuring Intel VMD

VMD must be enabled on PCIe ports which have NVMe drives attached to them in order for those drives to be added to a VROC RAID configuration. The default BIOS setting for the NVMe Mode Switch is Auto which automatically enables VMD on all installed NVMe drives.

NVMe Mode Switch:

- Auto: Enables VMD for all NVMe ports if VROC Key is installed.
- VMD: Enables VMD for all NVMe ports despite the lack of the VROC Key.
- Manual: Allows the user to select specific NVMe ports on which to enable VMD.

The NVMe Mode Switch can be viewed or selected at BIOS > Advanced > Chipset Configuration > North Bridge > IIO Configuration > Intel® VMD Technology.

Note: Without a VROC Key, there is no RAID support with the Auto switch. Only RAID 0 is supported with the VMD and Manual switches.

Configuring VMD Manually

The steps for manually configuring VMD on specific NVMe ports in UEFI BIOS are shown below. Example screenshots may differ from your server.

Important:

- If there is an existing RAID configuration, delete the RAID volume associated with the VMD controller before disabling the controller. Failure to do so may lead to unexpected behavior.
- The effects of physically changing or swapping a CPU on the VMD controller have not been thoroughly tested or documented.

1. Reboot the server and press [DEL] key to access the BIOS options.
2. Switch to Advanced > Chipset Configuration > North Bridge > IIO Configuration > Intel® VMD Technology.
3. Select VMD Mode Switch, then select Manual.

Note that Socket 0 contains CPU1; Socket 1 contains CPU2.

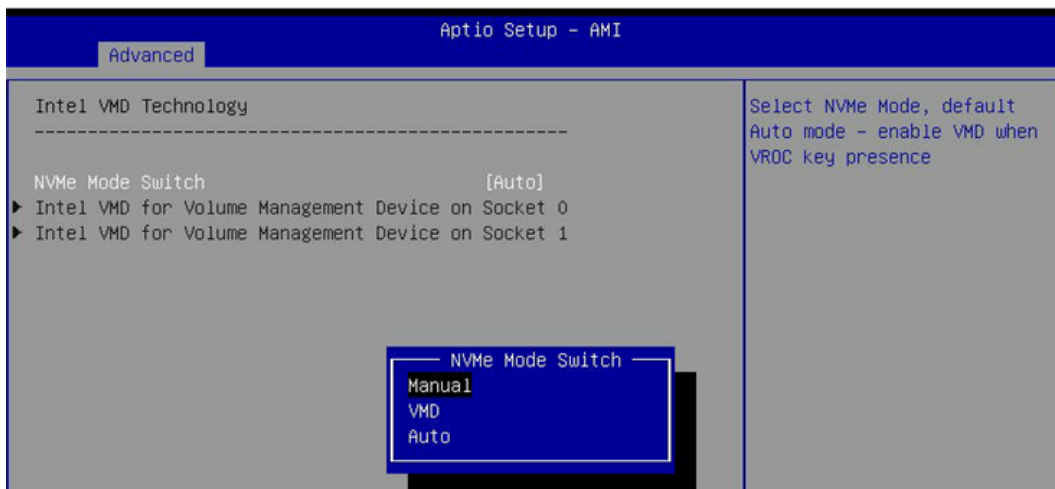

Figure 6-4. BIOS, Selecting VMD Mode

4. VMD must only be enabled on NVMe port resources. If VMD is enabled on other PCIe ports, the functionality of those ports will be impacted. See the table below.

Select “Intel VMD for Volume Management Device on” on Socket 0 (CPU1) or Socket 1 (CPU2) to enable VMD for devices under the respective CPU.

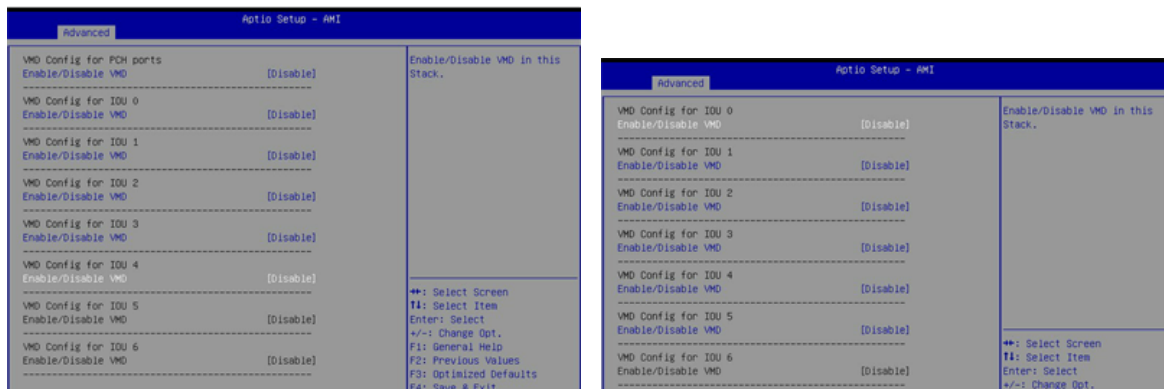

Figure 6-5. Intel VMD for Volume Management Device on Socket 0 and Socket 1

5. Choose Enable for “Enable/Disable VMD” for IOU 3 to list the available devices under IOU 3.

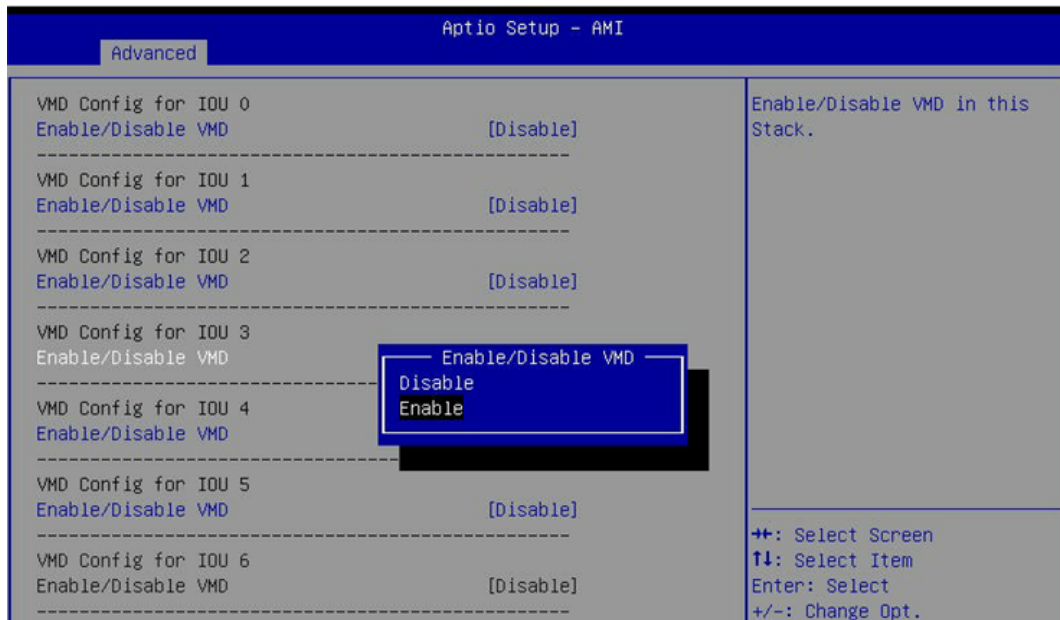

Figure 6-6. BIOS, Enabling VMD on Socket 1 (CPU2) (Example)

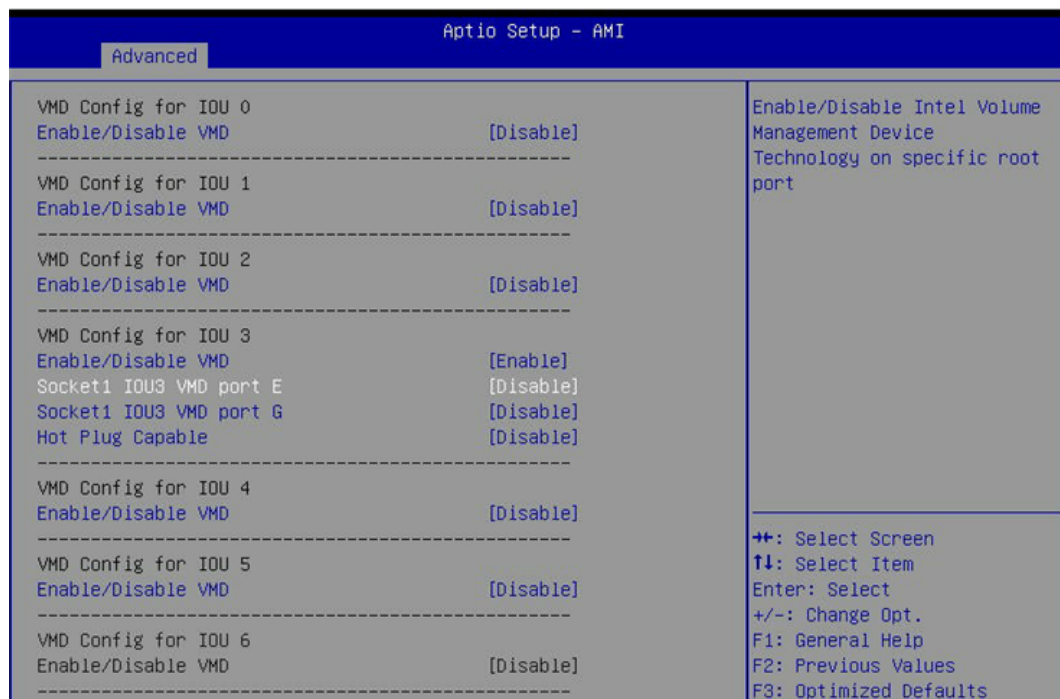

Figure 6-7. BIOS, Enabling VMD on Socket 1 (Example)

6. Enable the NVMe port resource according to table above for the NVMe drives that will be used in a RAID configuration.

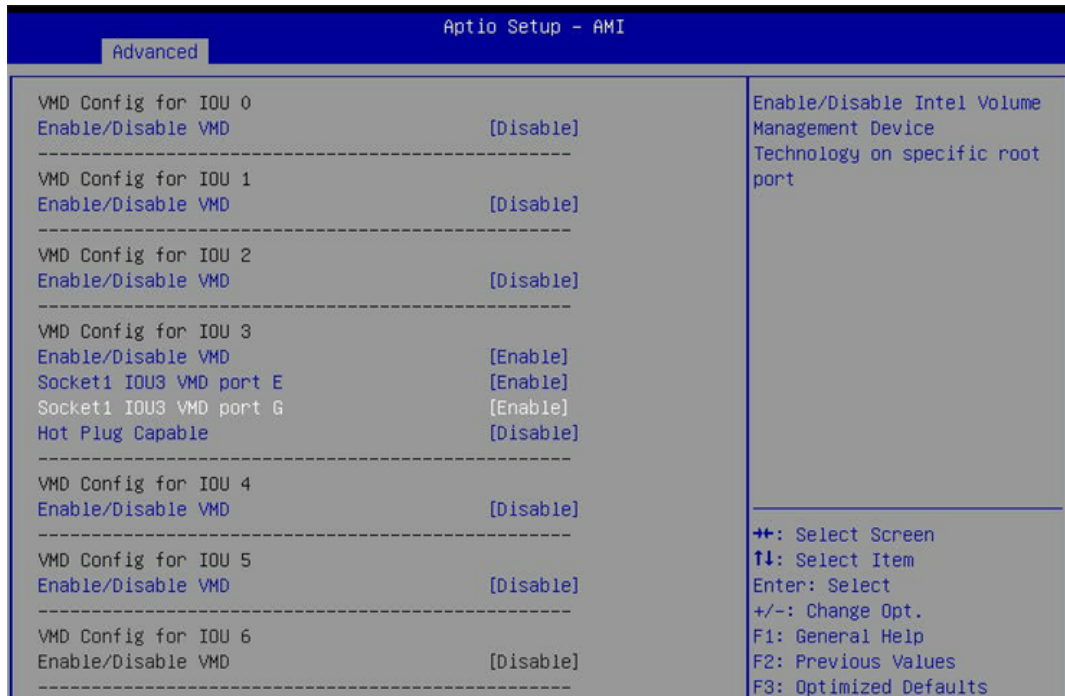

Figure 6-8. BIOS, Enabling Socket 1 (Example)

7. Choose whether to make the NVMe drives in this IOU Hot Plug Capable by selecting Enabled or Disabled.
8. Repeat steps 4 through 7 for each IOU # on each CPU to enable VMD on the desired NVMe ports.

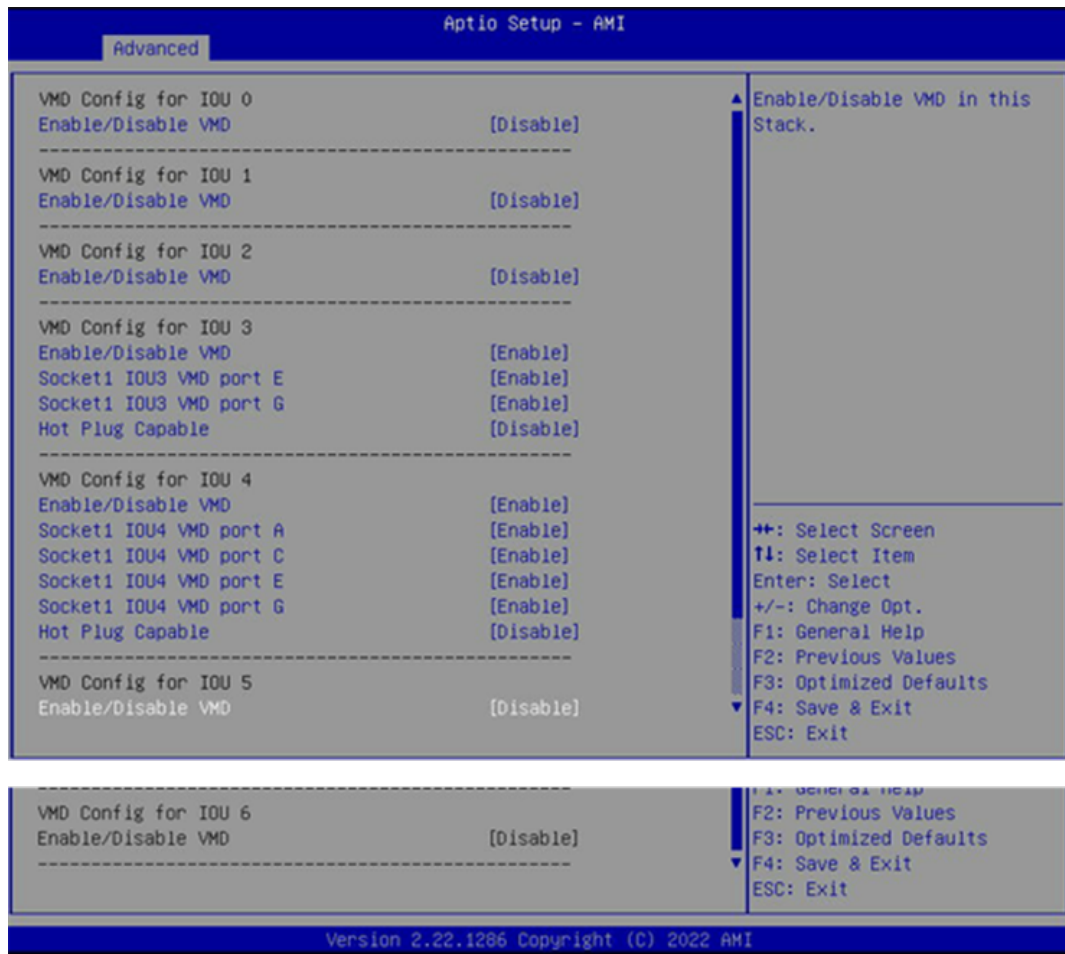

Figure 6-9. BIOS, Enabling Socket 1 Completed (Example)
 (This example shows SYS-621H-TN12R with 12 NVMe. Other systems will look different.)

9. Press [F4] to save the configuration and reboot the system.

Creating NVMe RAID Configurations

1. Open Advanced > Intel(R) Virtual RAID on CPU > All Intel VMD Controllers > Create RAID Volume.

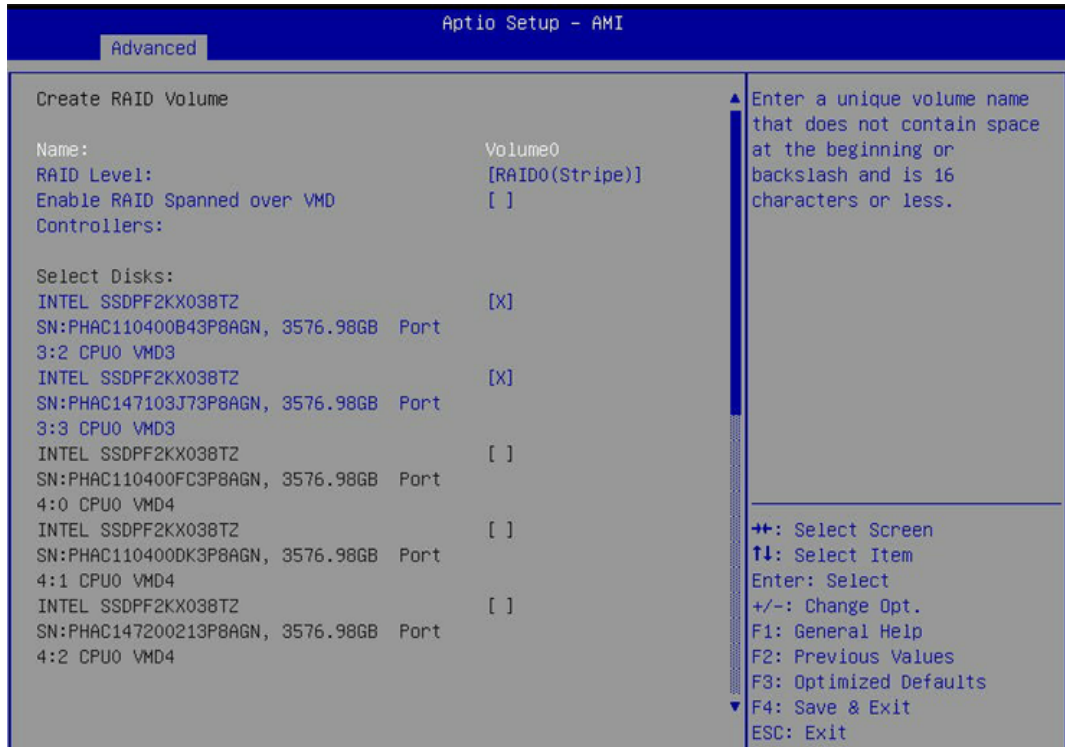

Figure 6-10. Creating Volume Without Enabling RAID Spanned over VMD Controller

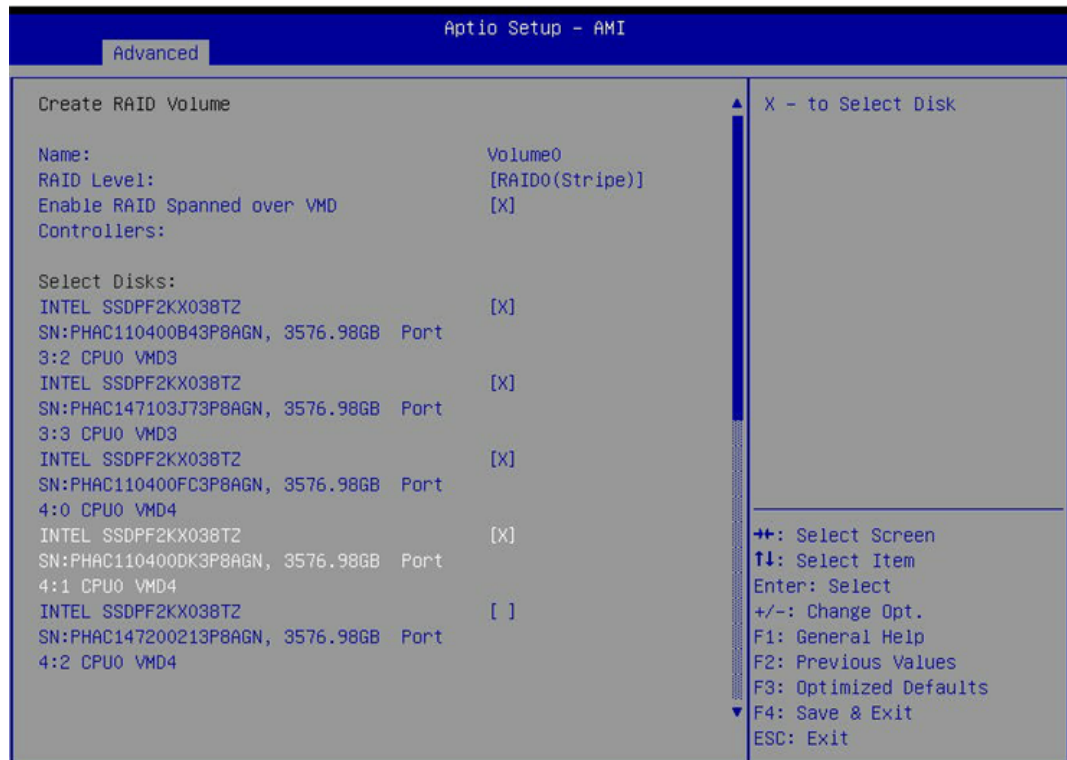

Figure 6-11. Creating Volume With Enabling RAID Spanned over VMD Controller

2. Set Name.
3. Set RAID Level.
4. If cross-controller RAID is required, select Enable RAID spanned over VMD Controller.
5. Select specific disks for RAID with an [X].
 - RAID0: Select at least two [2–24] disks
 - RAID1: Select only two disks
 - RAID5: Select at least three [3–24] disks
 - RAID10: Select only four disks
6. Select Strip Size (Default 64 KB).
7. Select Create Volume.
8. If another RAID is needed, start again at step 1.

Status Indications

An LED indicator on the drive carrier shows the RAID status of the drive.

Drive Carrier Status LED Indicator	
Status	State (red)
Normal function	Off
Locating	4 Hz blinking
Fault	Solid on
Rebuilding	1 Hz blinking
IBPI SFF 8489 Defined Status LED States	

Hot-Swap Drives

Intel VMD enables hot-plug and hot-unplug for NVMe SSDs, whether from Intel or other manufacturers. Under vSphere ESXi, several steps are necessary to avoid potential stability issues. See the information at link [1] below.

Hot-Unplug

1. Prevent devices from being re-detected during rescan:

```
esxcli storage core claiming autoclaim --enabled=false
```
2. Unmount the VMFS volumes on the device. Check link [2] below for details.
3. Detach the device. Check link [3] below for details.
4. Physically remove the device.

Hot-Plug

- Physically install the device.

ESXi will automatically discover NVMe SSDs, but a manual scan may be required in some cases.

Related Information Links

1. <https://kb.vmware.com/s/article/2151404>
2. <https://docs.vmware.com/en/VMware-vSphere/6.5/com.vmware.vsphere.storage.doc/GUID-1B56EF97-F60E-4F21-82A7-8F2A7294604D.html>
3. <https://docs.vmware.com/en/VMware-vSphere/6.5/com.vmware.vsphere.storage.doc/GUID-F2E75F67-740B-4406-9F0C-A2D99A698F2A.html>

Chapter 7:

Troubleshooting and Support

The following content contains information on common issues and how to resolve them.

7.1 Online Resources	129
Direct Links for the SYS-622B-TRT System	129
Direct Links for General Support and Information	129
7.2 Baseboard Management Controller (BMC)	130
7.3 Troubleshooting Procedures	131
Before Power On	131
No Power	131
No Video	131
System Boot Failure	131
Memory Errors	132
Losing the System's Setup Configuration	132
If the System Becomes Unstable	132
7.4 CMOS Clear	134
7.5 Motherboard Battery	135
7.6 Where to Get Replacement Components	136
7.7 Technical Support Procedures	137
Returning Merchandise for Service	137
7.8 Feedback	139

7.1 Online Resources

A great deal of information is available on the Supermicro website. From the top menu of the Supermicro home page at <https://www.supermicro.com>:

- Specifications for servers and other hardware are available by clicking **Products**.
- The **Support** option offers downloads (manuals, BIOS/BMC, drivers, etc.), FAQs, RMA, warranty, and other service extensions.

Direct Links for the SYS-622B-TRT System

SYS-622B-TRT Specification Page:

<https://www.supermicro.com/en/products/system/mainstream/2u/sys-622b-trt>

Direct Links for General Support and Information

Tested Memory List

- General Memory Configuration Guide for X14 and B14 motherboards that use Intel® Xeon® 6700-series processors:
https://www.supermicro.com/support/resources/memory/X14_B14_memory_config_guide_SP.pdf
- Frequently Asked Questions: <https://www.supermicro.com/FAQ/index.php>
- TPM User Guide: https://www.supermicro.com/manuals/other/AOM-TPM-9670V_9670H_X12_H12.pdf
- BMC User Guide: https://www.supermicro.com/manuals/other/BMC_IPMI_X14_H14.pdf
- Product Resources page for validated memory details:
<https://www.supermicro.com/support/resources/mem.cfm>
- Product Matrices page for links to tables summarizing specs for systems, motherboards, power supplies, riser cards, add-on cards, and more:
<https://www.supermicro.com/en/support/product-matrices>
- Security Center for recent security notices:
https://www.supermicro.com/en/support/security_center
- Supermicro Phone and Addresses: <https://www.supermicro.com/en/about/contact>

7.2 Baseboard Management Controller (BMC)

The SYS-622B-TRT server supports the Baseboard Management Controller (BMC). BMC is used to provide remote access, monitoring, and management. There are several BIOS settings that are related to BMC.

For general documentation and information on BMC, visit our website at the following page:

<https://www.supermicro.com/en/solutions/management-software/bmc-resources>

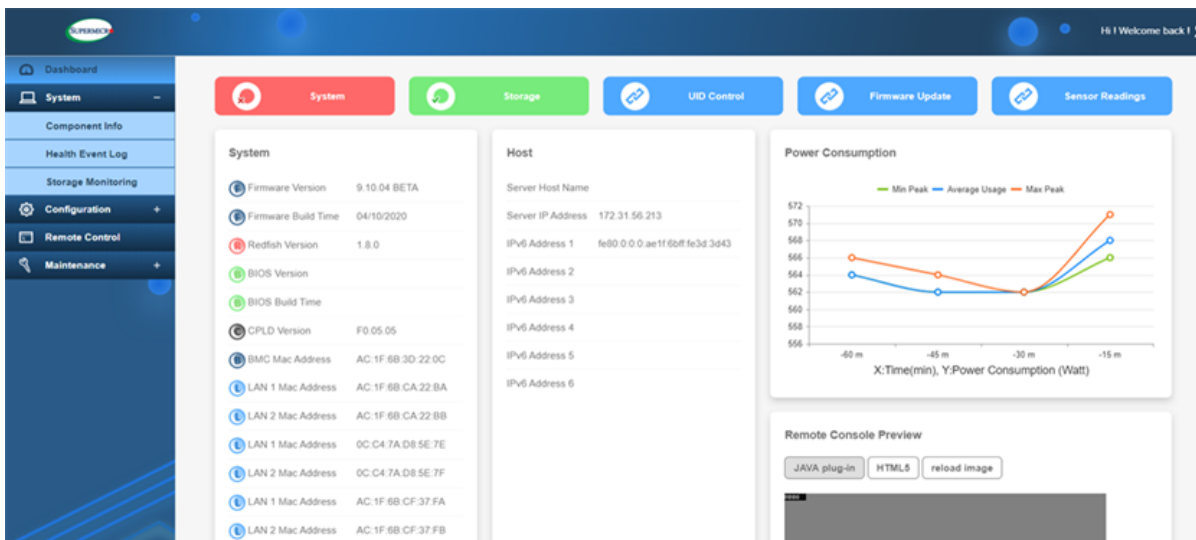

Figure 7-1. BMC Dashboard

7.3 Troubleshooting Procedures

Use the following procedures to troubleshoot your system. If you have followed all of the procedures below and still need assistance, refer to the ["Technical Support Procedures" on page 137](#) section in this chapter. Always disconnect the AC power cord before adding, changing or installing any non hot-swap hardware components. If the below steps do not fix the setup configuration problem, contact your vendor for repairs.

Before Power On

1. Make sure that there are no short circuits between the motherboard and chassis.
2. Disconnect all ribbon/wire cables from the motherboard, including those for the keyboard and mouse.
3. Remove all add-on cards.
4. Install the processor (making sure it is fully seated) and connect the front panel connectors to the motherboard.

No Power

1. Make sure that there are no short circuits between the motherboard and the chassis.
2. The battery on your motherboard may be old. Check to verify that it still supplies approximately 3 VDC. If it does not, replace it with a new one.

No Video

1. If the power is on, but you do not have video, remove all add-on cards and cables.
2. Remove all memory modules and turn on the system (if the alarm is on, check the specs of memory modules, reset the memory, or try a different one).

System Boot Failure

If the system does not display Power-On-Self-Test (POST) or does not respond after the power is turned on, do the following:

1. Remove all components from the motherboard, especially the DIMMs. Power on the system and check if the power-on LED and the BMC Heartbeat LED are on, and system fans are spinning.

2. Turn on the system with only one DIMM installed. If the system boots, check for bad DIMMs or slots by following the Memory Errors Troubleshooting procedure in this chapter.

Memory Errors

When suspecting faulty memory is causing the system issue, check the following:

1. Make sure that the memory modules are compatible with the system and are properly installed. See "[Maintenance and Component Installation](#)" on [page 40](#) for installation instructions. (For memory compatibility, refer to the "Tested Memory List" link on the motherboard's product page to see a list of supported memory.)
2. Check if different speeds of DIMMs have been installed. It is strongly recommended that you use the same RAM type and speed for all DIMMs in the system.
3. Make sure that you are using the correct type of DIMMs recommended by the manufacturer.
4. Check for bad DIMMs or slots by swapping a single module among all memory slots and check the results.

Losing the System's Setup Configuration

1. Make sure that you are using a high-quality power supply. A poor-quality power supply may cause the system to lose the CMOS setup information. Refer to "[Introduction](#)" on [page 12](#) for details on recommended power supplies.
2. The battery on your motherboard may be old. Check to verify that it still supplies approximately 3 VDC. If it does not, replace it with a new one.

If the System Becomes Unstable

If the system becomes unstable during or after OS installation, check the following:

1. Processor/BIOS support: Make sure that your processor is supported and that you have the latest BIOS installed in your system.
2. Memory support: Make sure that the memory modules are supported. Refer to the product page on our website at <https://www.supermicro.com>. Test the modules using memtest86 or a similar utility.

Note: Click on the "Tested Memory List" link on the motherboard's product page to see a list of supported memory.

3. Storage Drive support: Make sure that all storage drives work properly. Replace the failed storage drives with good ones.
4. System cooling: Check the system cooling to make sure that all heatsink fans and processor/system fans, etc., work properly. Check the hardware monitoring settings in the BMC to make sure that the processor and system temperatures are within the normal range. Also, check the front panel Overheat LED and make sure that it is not on.
5. Adequate power supply: Make sure that the power supply provides adequate power to the system. Make sure that all power connectors are connected. Refer to our website for more information on the minimum power requirements.
6. Proper software support: Make sure that the correct drivers are used.

If the system becomes unstable before or during OS installation, check the following:

1. Source of installation: Make sure that the devices used for installation are working properly, including boot devices such as a CD/Media drive.
2. Cable connection: Check to make sure that all cables are connected and working properly.
3. Use the minimum configuration for troubleshooting: Remove all unnecessary components (starting with add-on cards first), and use the minimum configuration (but with the processor and a memory module installed) to identify the trouble areas. Refer to the steps listed above in this section for proper troubleshooting procedures.
4. Identify bad components by isolating them: If necessary, remove a component in question from the chassis, and test it in isolation to make sure that it works properly. Replace a bad component with a good one.
5. Check and change one component at a time instead of changing several items at the same time. This will help isolate and identify the problem.
6. To find out if a component is good, swap this component with a new one to see if the system will work properly. If so, then the old component is bad. You can also install the component in question in another system. If the new system works, the component is good and the old system has problems.

7.4 CMOS Clear

JBT1 on the X14DBI-T motherboard is used to clear CMOS, which will also clear any passwords. For information on clearing CMOS, refer to ["CMOS Clear" on page 101](#) earlier in this manual.

7.5 Motherboard Battery

For information on removing, disposing of, and replacing the motherboard battery of your system, refer to ["Motherboard Battery Removal and Installation" on page 74](#).

7.6 Where to Get Replacement Components

If you need replacement parts for your SYS-622B-TRT server, to ensure the highest level of professional service and technical support, purchase exclusively from our Supermicro Authorized Distributors/System Integrators/Resellers. A list can be found on the Supermicro website:

<https://www.supermicro.com>

Under the "Buy" menu, click the "Where to Buy" link.

7.7 Technical Support Procedures

Before contacting Technical Support, take the following steps. Also, note that as a motherboard manufacturer, Supermicro also sells motherboards through its channels, so it is best to first check with your distributor or reseller for troubleshooting services. They should know of any possible problems with the specific system configuration that was sold to you.

1. Refer to "Troubleshooting Procedures" on page 131 or see the FAQs on our website (<https://www.supermicro.com/FAQ/index.php>) before contacting Technical Support.
2. BIOS upgrades can be downloaded from our website (https://www.supermicro.com/support/resources/bios_ipmi.php).
3. If you still cannot resolve the problem, include the following information when contacting Supermicro for technical support:
 - Motherboard model and PCB revision number
 - BIOS release date/version (This can be seen on the initial display when your system first boots up.)
 - System configuration
4. An example of a Technical Support form is on our website at <https://webpr3.supermicro.com/SupportPortal>.
5. Distributors: For immediate assistance, have your account number ready when placing a call to our Technical Support department. For Supermicro contact information, refer to "Contacting Supermicro" on page 11.

Returning Merchandise for Service

A receipt or copy of your invoice marked with the date of purchase is required before any warranty service will be rendered. You can obtain service by calling your vendor for a Returned Merchandise Authorization (RMA) number. When returning the server to the manufacturer, the RMA number should be prominently displayed on the outside of the shipping carton, and the shipping package is mailed prepaid or hand-carried. Shipping and handling charges will be applied for all orders that must be mailed when service is complete.

For faster service, RMA authorizations can be requested online at the following page:

<https://www.supermicro.com/RmaForm>

Whenever possible, repack the server in the original Supermicro carton, using the original packaging material. If these are no longer available, be sure to pack the server securely, using packaging material to surround the server so that it does not shift within the carton and become damaged during shipping.

This warranty only covers normal consumer use and does not cover damages incurred in shipping or from failure due to the alternation, misuse, abuse or improper maintenance of products.

During the warranty period, contact your distributor first for any product problems.

7.8 Feedback

Supermicro values your feedback as we strive to improve our customer experience in all facets of our business. Email us at Techwriterteam@supermicro.com to provide feedback on our manuals.

Chapter 8:

UEFI BIOS

The following content contains information on BIOS configuration with the SYS-622B-TRT server.

8.1 Introduction	141
8.2 Main Setup	143
8.3 Advanced Setup Configurations	145
8.4 Event Logs	146
8.5 BMC	147
8.6 Security	148
8.7 Boot	150
8.8 Save & Exit	152

8.1 Introduction

This chapter describes the AMIBIOS™ Setup utility for the motherboard. The BIOS is stored on a chip and can be easily upgraded using the UEFI script (flash.nsh), the BMC WebUI, or the SuperServer Automation Assistant (SAA) utility.

Note: Due to periodic changes to the BIOS, some settings may have been added or deleted and might not yet be recorded in this manual. Refer to the Manual Download area of our website for any changes to BIOS that may not be reflected in this manual.

Updating BIOS

It is recommended that you do not upgrade your BIOS if you are not experiencing any problems with your system. Updated BIOS files are located on our website at the following page:

https://www.supermicro.com/support/resources/bios_ipmi.php

Check our BIOS warning message and the information on how to update your BIOS on our website. Select your motherboard model and download the BIOS file to your computer. Also, check the current BIOS revision to make sure that it is newer than your BIOS before downloading.

Important: Do not shut down or reset the system while updating the BIOS to prevent possible system boot failure! Read the motherboard README file carefully before you perform the BIOS update.

Unzip the BIOS file onto a bootable USB device and then boot into the built-in UEFI Shell and type "flash.nsh <BIOS filename><BMC Username><BMC Password>" to start the BIOS update. The flash script will invoke the SCC (EFI) tool automatically to perform the BIOS update, beginning with uploading the BIOS image to BMC. After uploading the firmware, the system will reboot to continue the process. The BMC will take over and continue the BIOS update in the background. The process will take 3–5 minutes.

Starting the Setup Utility

To enter the BIOS Setup utility, press the <Delete> key while the system is booting-up. In most cases, the <Delete> key is used to invoke the BIOS Setup screen. There are a few cases when other hot keys are used, such as <F1>, <F2>, etc. Each main BIOS menu option is described in this manual.

The Main BIOS screen has two main frames. The left frame displays all the options that can be configured. "Grayed-out" options cannot be configured. The right frame displays the key legend. Above the key legend is an area reserved for a text message. When a BIOS submenu or item is selected in the left frame, it is highlighted in white. Often a text message will accompany it. (Note that BIOS has default text messages built in. We retain the option to include, omit, or change any of these text messages.) Settings printed in **Bold** are the default values.

A "▶" indicates a submenu. Highlighting such an item and pressing the <Enter> key open the list of settings within that submenu.

The BIOS Setup utility uses a key-based navigation system called hot keys. Most of these hot keys (<F1>, <F2>, <F3>, <F4>, <F5>, <F6>, <Enter>, <ESC>, the arrow keys, etc.) can be used at any time during the setup navigation process.

8.2 Main Setup

The Main setup screen appears when the AMI BIOS Setup utility is first entered. To return to the Main setup screen, select the Main tab at the top of the screen. The Main BIOS setup screen is shown below.

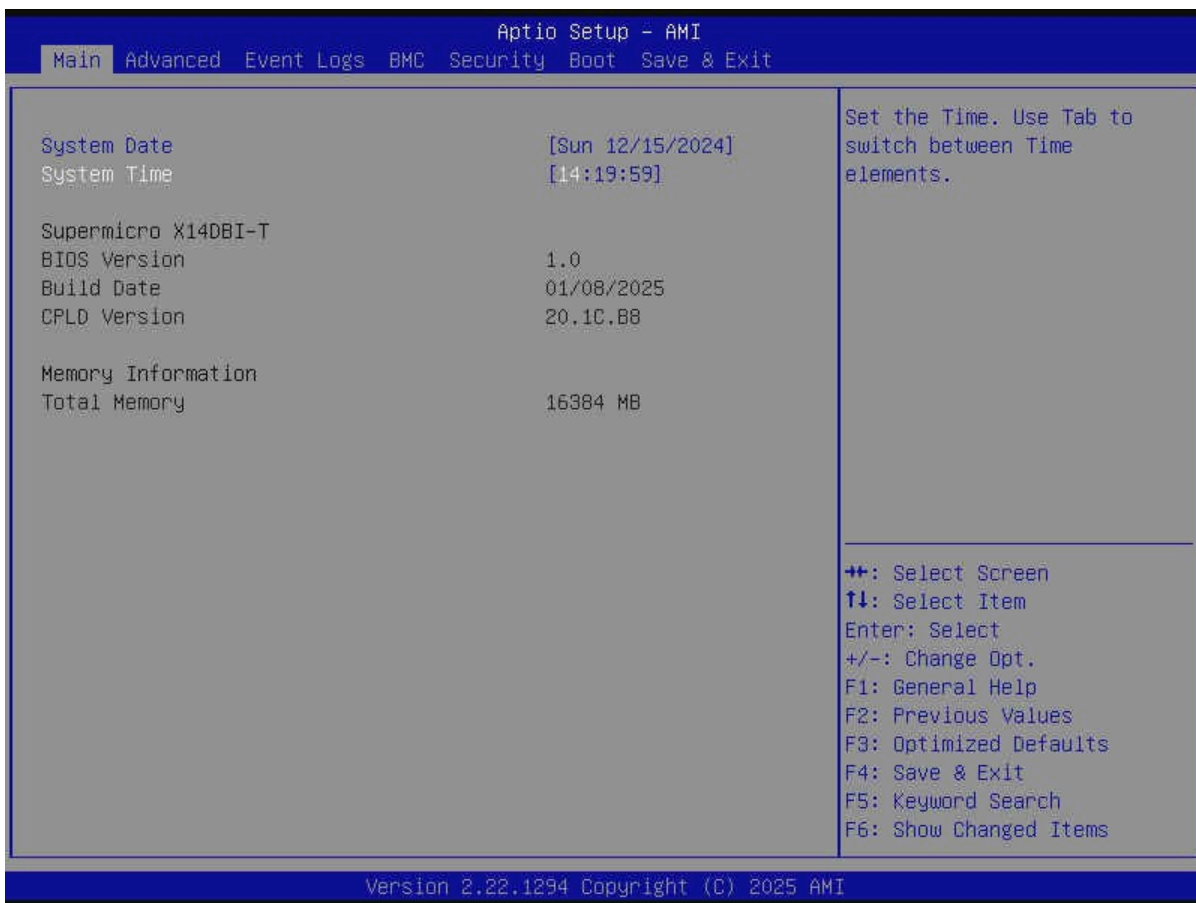

Figure 8-1. Main Setup Screen

System Date/System Time

Use the two features to change the system date and time. Highlight **System Date** or **System Time** using the arrow keys. Enter new values using the keyboard. Press the <Tab> key or the arrow keys to move between fields. The date must be entered in MM/DD/YYYY format. The time is entered in HH:MM:SS format.

Note: The time is in the 24-hour format. For example, 5:30 P.M. appears as 17:30:00.

Supermicro X14DBI-T

BIOS Version

This feature displays the version of the BIOS ROM used in the system.

Build Date

This feature displays the date when the version of the BIOS ROM used in the system was built.

CPLD Version

This feature displays the version of the Complex-Programmable Logical Device (CPLD) used in the system.

Memory Information**Total Memory**

This feature displays the total size of memory available in the system.

8.3 Advanced Setup Configurations

Use the arrow keys to select the Advanced submenu and press <Enter> to access the submenu items.

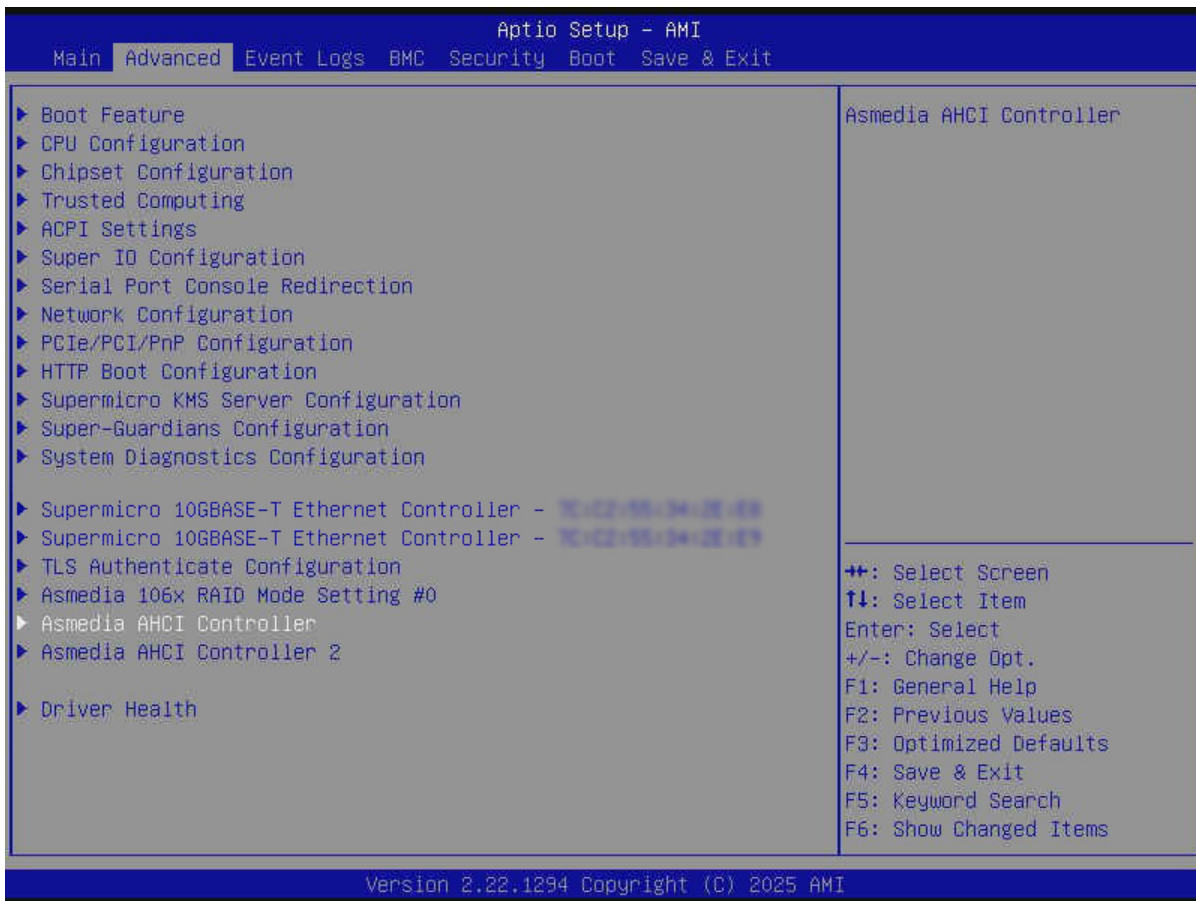

Figure 8-2. Advanced Setup Configuration Screen



Warning! Take caution when changing the Advanced settings. An incorrect value, an improper DRAM frequency, or a wrong BIOS timing setting may cause the system to malfunction. When this occurs, revert the setting to the manufacture default settings.

8.4 Event Logs

Use this feature to configure Event Logs settings.

Note: After you've made any changes in this section, please be sure to reboot the system for the changes to take effect.

► Change SMBIOS Event Log Settings

Note: Reboot the system for the changes in this section to take effect.

8.5 BMC

Use this menu to configure Baseboard Management Console (BMC) settings.

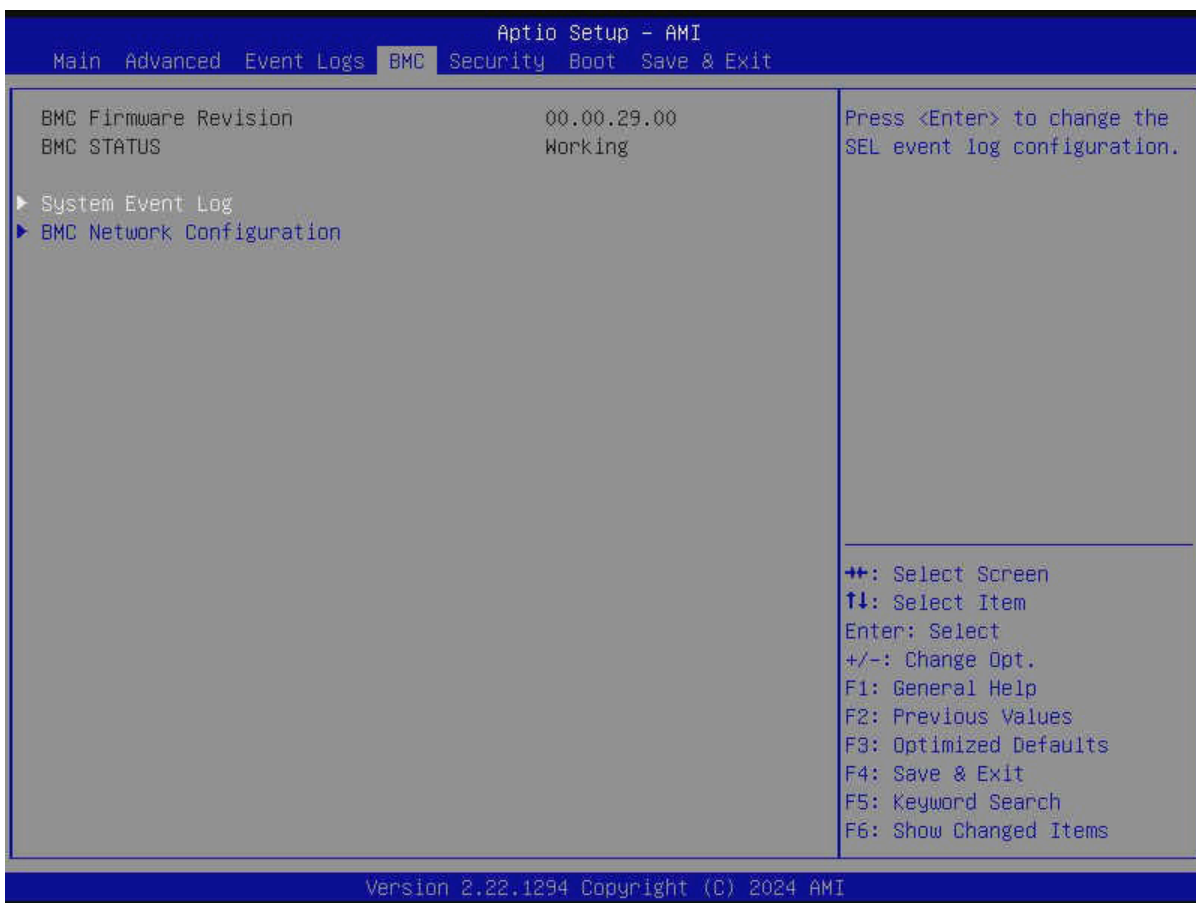

Figure 8-3. BMC Setup Screen

BMC Firmware Revision

This feature indicates the BMC firmware revision used in this system.

BMC STATUS

This feature indicates the status of the BMC firmware installed in this system.

8.6 Security

Use this menu to configure the following security settings for the system.

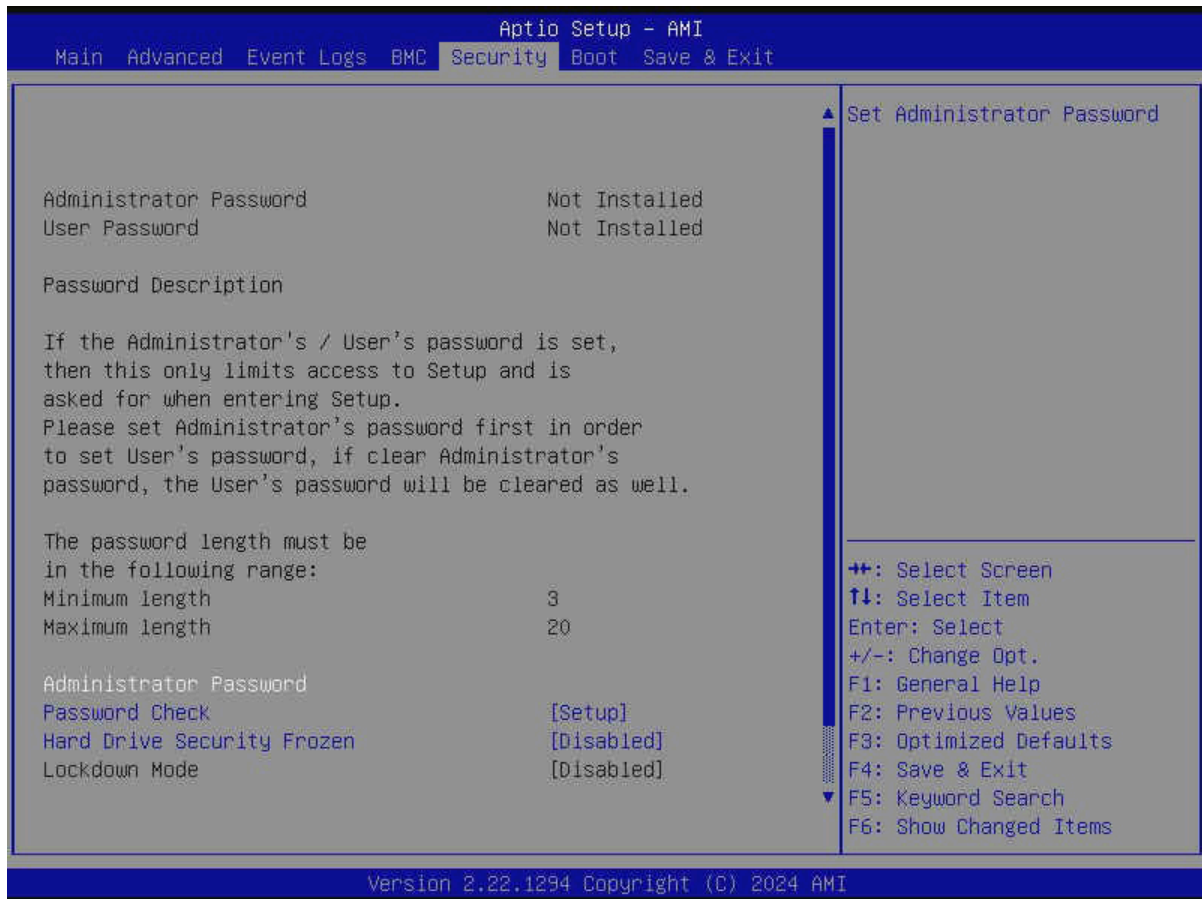

Figure 8-4. Security Setup Screen

Disable Block Sid and Freeze Lock (Available when your storage devices support TCG)

Select Enabled to allow SID authentication to be performed in TCG storage devices. The options are **Disabled** and Enabled.

The following information is displayed:

- Administrator Password
- User Password
- Password Description

Administrator Password

This feature indicates if an administrator password has been installed. Use this feature to set the administrator password, which is required to enter the BIOS Setup utility. The length of the password can be between three and 20 characters long.

User Password (Available when "Administrator Password" has been set)

This feature indicates if a user password has been installed. Use this feature to set the user password which is required to enter the BIOS Setup utility. The length of the password can be between three and 20 characters long.

Password Check

Select Setup for the system to check for a password upon entering the BIOS Setup utility. Select Always for the system to check for the passwords needed at bootup and upon entering the BIOS Setup utility. The options are **Setup** and Always.

Hard Drive Security Frozen

Select Enabled to freeze the Lock Security feature for HDD to protect key data in hard drives from being altered. The options are **Disabled** and Enabled.

Lockdown Mode (Available when the DCMS key is activated)

Select Enabled to support the Lockdown Mode, which prevents the existing data or keys stored in the system from being altered or changed in an effort to preserve system integrity and security. The options are **Disabled** and Enabled.

8.7 Boot

Use this menu to configure Boot settings.

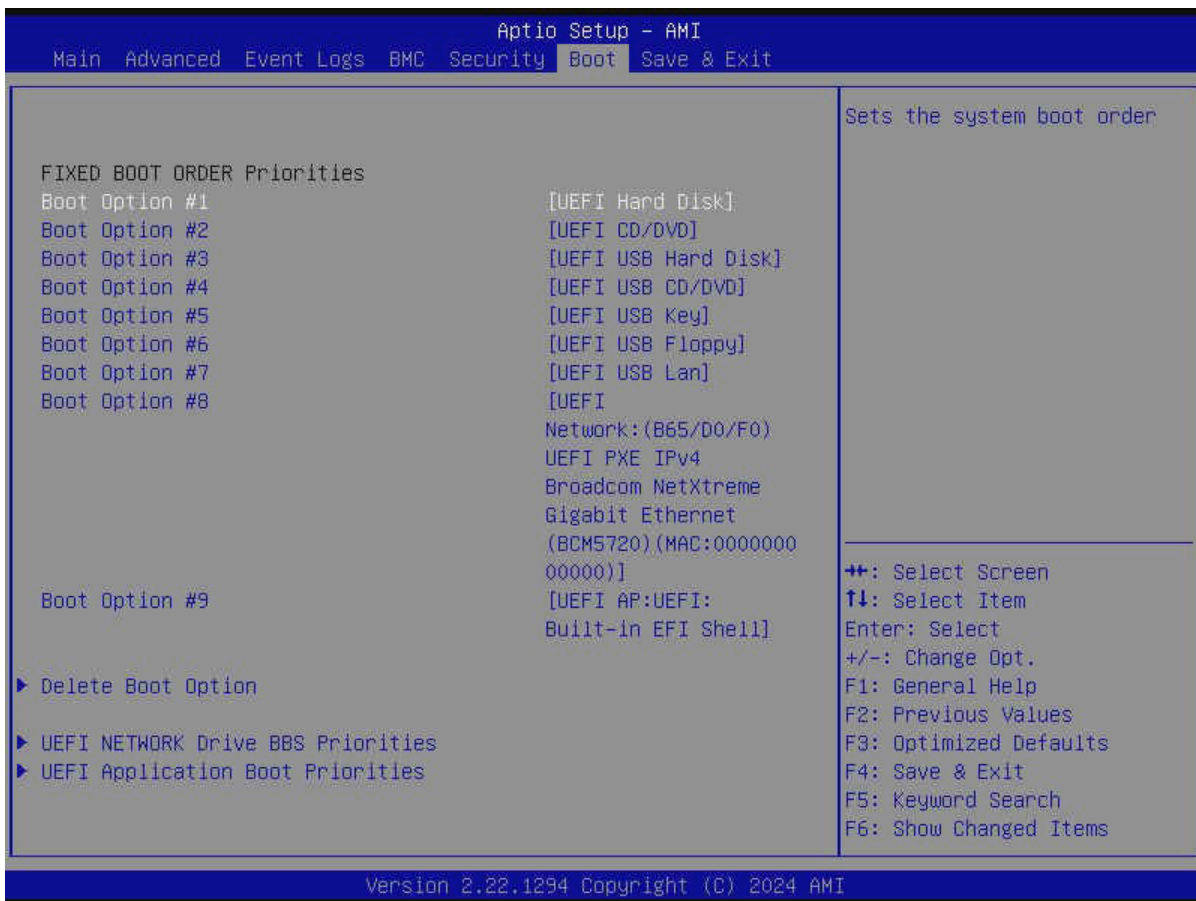

Figure 8-5. Boot Setup Screen

FIXED BOOT ORDER Priorities

Use this feature to prioritize the order of a bootable device from which the system will boot. Press <Enter> on each item sequentially to select the device.

- Boot Option #1 – Boot Option #9

► Add New Boot Option

Use this feature to add a new boot option to the boot priority features for system boot.

Note: This submenu is available when any storage device is detected by the BIOS.

Add boot option

Use this feature to specify the name for the new boot option.

Path for boot option

Use this feature to enter the path for the new boot option in the format fsx:\path\filename.efi.

Boot option File Path

Use this feature to specify the file path for the new boot option.

Create

After setting the name and the file path for the boot option, press <Enter> to create the new boot option in the boot priority list.

▶ Delete Boot Option

Use this feature to select a boot device to delete from the boot priority list.

Delete Boot Option

Use this feature to remove an EFI boot option from the boot priority list.

▶ UEFI NETWORK Drive BBS Priorities

Use this feature to set the system boot order of detected devices.

▶ UEFI Application Boot Priorities

Use this feature to set the system boot order of detected devices.

▶ UEFI USB Key Drive BBS Priorities

Use this feature to set the system boot order of detected devices.

▶ UEFI Hard Disk Drive BBS Priorities

Use this feature to set the system boot order of detected devices.

8.8 Save & Exit

Select Save & Exit from the BIOS Setup screen to configure the settings below.

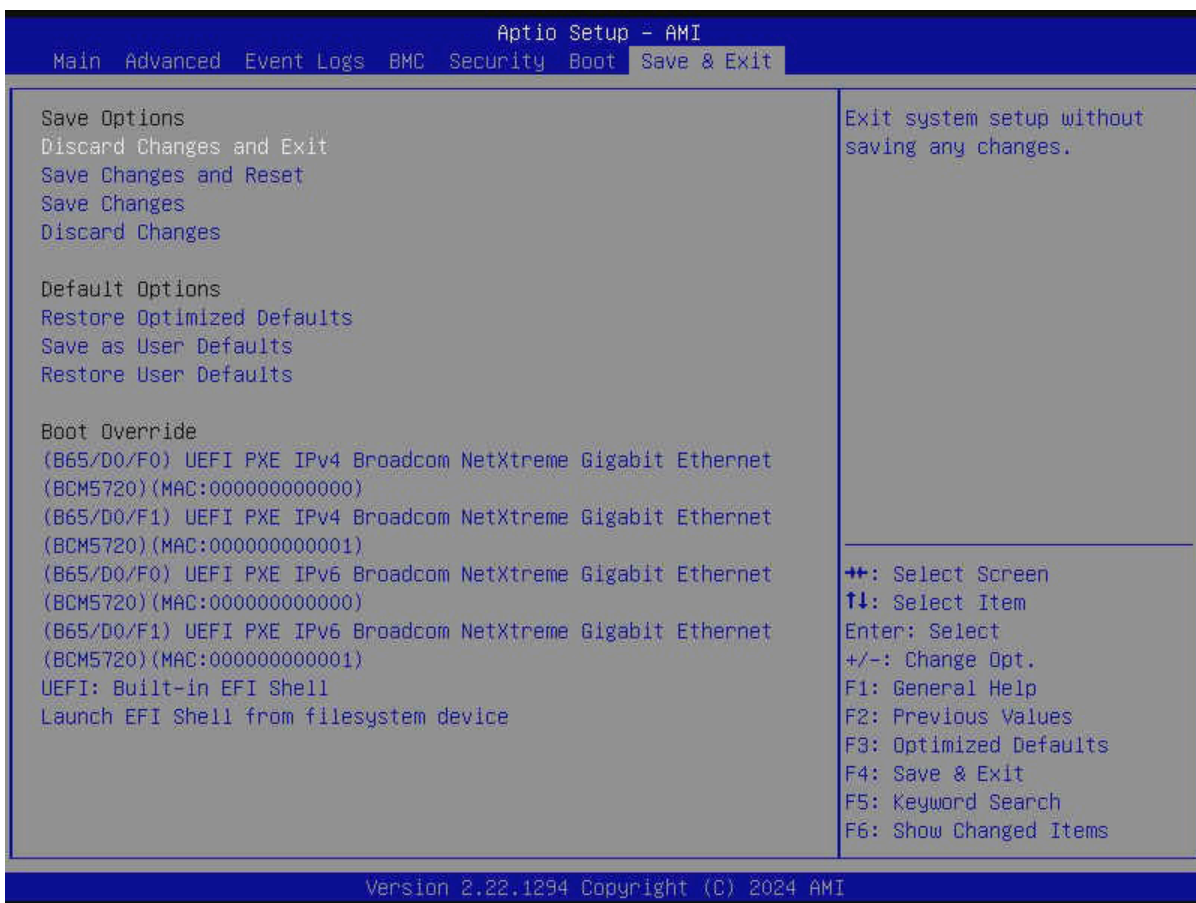

Figure 8-6. Save & Exit Screen

Save Options

Discard Changes and Exit

Use this feature to exit from the BIOS Setup utility without making any permanent changes to the system configuration and reboot the computer.

Save Changes and Reset

On completing the system configuration changes, use this feature to exit the BIOS Setup utility and reboot the computer for the new system configuration parameters to take effect.

Save Changes

On completing the system configuration changes, use this feature to save all changes made. This will not reset (reboot) the system.

Discard Changes

Select this feature and press <Enter> to discard all changes made and return to the BIOS Setup utility.

Default Options**Restore Optimized Defaults**

Select this feature and press <Enter> to load manufacturer optimized default settings, which are intended for maximum system performance but not for maximum stability.

Note: After pressing <Enter>, reboot the system for the changes to take effect, which ensures that this system has the optimized default settings.

Save As User Defaults

Select this feature and press <Enter> to save all changes as the default values specified to the BIOS Setup utility for future use.

Restore User Defaults

Select this feature and press <Enter> to retrieve user-defined default settings that have been saved previously.

Boot Override

Note: Use this section to override the Boot priorities sequence in the Boot menu, and immediately boot the system with a device specified here instead of the one specified in the boot list. This is a one-time boot override.

Launch EFI Shell from filesystem device

Use this feature to launch the EFI shell application (Shell.efi) from one of the available filesystem devices. A filesystem is a virtual, logical, or physical system for organizing, managing, and accessing the files and directories on devices such as SSDs, HDDs, or other storage devices.

Appendix A:

BIOS Codes

For information about BIOS codes for the SYS-622B-TRT server, refer to the following content.

BIOS Error POST (Beep) Codes

During the Power-On Self-Test (POST) routines, which are performed each time the system is powered on, errors may occur.

Non-fatal errors are those which, in most cases, allow the system to continue the boot up process. The error messages normally appear on the screen.

Fatal errors are those which will not allow the system to continue the boot up process. If a fatal error occurs, you should consult with your system manufacturer for possible repairs.

These fatal errors are usually communicated through a series of audible beeps that can be heard on an external buzzer connected to JD1. The table shown below lists some common errors and their corresponding beep codes encountered by users.

BIOS Beep (POST) Codes		
Beep Code	Error Message	Description
1 beep	Refresh	Circuits have been reset (Ready to power up)
5 short, 1 long	Memory error	No memory detected in system
5 short, 2 long	Display memory read/write error	Video adapter missing or with faulty memory
1 long continuous	System OH	System overheat condition

Additional BIOS POST Codes

The AMI BIOS supplies additional checkpoint codes, which are documented online at <https://www.supermicro.com/support/manuals> ("AMI BIOS POST Codes User's Guide").

For information on AMI updates, refer to <https://www.ami.com/products>.

Appendix B:

Standardized Warning Statements for AC Systems

The following statements are industry standard warnings, provided to warn the user of situations which have the potential for bodily injury. Should you have questions or experience difficulty, contact Supermicro's Technical Support department for assistance. Only certified technicians should attempt to install or configure components.

Read this section in its entirety before installing or configuring components in the Supermicro SYS-622B-TRT server.

These warnings may also be found on our website at the following page:

https://www.supermicro.com/about/policies/safety_information.cfm

Warning Definition



Warning! This warning symbol means danger. You are in a situation that could cause bodily injury. Before you work on any equipment, be aware of the hazards involved with electrical circuitry and be familiar with standard practices for preventing accidents.

警告の定義

この警告サインは危険を意味します。

人身事故につながる可能性がありますので、いずれの機器でも動作させる前に、電気回路に含まれる危険性に注意して、標準的な事故防止策に精通して下さい。

此警告符号代表危險。

您正处于可能受到严重伤害的工作环境中。在您使用设备开始工作之前，必须充分意识到触电的危险，并熟练掌握防止事故发生的标准工作程序。请根据每项警告结尾的声明号码找到此设备的安全性警告说明的翻译文本。

此警告符號代表危險。

您正處於可能身體可能會受損傷的工作環境中。在您使用任何設備之前，請注意觸電的危險，並且要熟悉預防事故發生的標準工作程序。請依照每一注意事項後的號碼找到相關的翻譯說明內容。

Warnung

WICHTIGE SICHERHEITSHINWEISE

Dieses Warnsymbol bedeutet Gefahr. Sie befinden sich in einer Situation, die zu Verletzungen führen kann. Machen Sie sich vor der Arbeit mit Geräten mit den Gefahren elektrischer Schaltungen und den üblichen Verfahren zur Vorbeugung vor Unfällen vertraut. Suchen Sie mit der am Ende jeder Warnung angegebenen Anweisungsnummer nach der jeweiligen Übersetzung in den übersetzten Sicherheitshinweisen, die zusammen mit diesem Gerät ausgeliefert wurden.

BEWAHREN SIE DIESE HINWEISE GUT AUF.

INSTRUCCIONES IMPORTANTES DE SEGURIDAD

Este símbolo de aviso indica peligro. Existe riesgo para su integridad física. Antes de manipular cualquier equipo, considere los riesgos de la corriente eléctrica y familiarícese con los procedimientos estándar de prevención de accidentes. Al final de cada advertencia encontrará el número que le ayudará a encontrar el texto traducido en el apartado de traducciones que acompaña a este dispositivo.

GUARDE ESTAS INSTRUCCIONES.

IMPORTANTES INFORMATIONS DE SÉCURITÉ

Ce symbole d'avertissement indique un danger. Vous vous trouvez dans une situation pouvant entraîner des blessures ou des dommages corporels. Avant de travailler sur un équipement, soyez conscient des dangers liés aux circuits électriques et familiarisez-vous avec les procédures couramment utilisées pour éviter les accidents. Pour prendre connaissance des traductions des avertissements figurant dans les consignes de sécurité traduites qui accompagnent cet appareil, référez-vous au numéro de l'instruction situé à la fin de chaque avertissement.

CONSERVEZ CES INFORMATIONS.

תקנון הצהרות אזהרה

הצהרות הבאות הן אזהרות על פי תקני התעשייה, על מנת להזהיר את המשתמש מפני חבלה פיזית אפשרית. במידה ויש שאלות או היתקלות בבעיה כלשהי, יש ליצור קשר עם מחלקת תמיכה טכנית של סופרמיקרו. טכנאים מוסמכים בלבד רשאים להתקין או להגדיר את הרכיבים. יש לקרוא את הנספח במלואו לפני התקנת או הגדרת הרכיבים במארזי סופרמיקרו.

الكافة حالة وكي أي تتسبب ف اصابة جسده هذا الزهر ع خطر! تحذّر.
قبل أي تعول على أي هعدات، كي على علن بالوخاظر ال اجوة عي النوانز
الكهرباء

وكي على دراة بالووارسات النقاء ة لو ع وقع أي حداثث
استخدم رغن الب إى الو صنص ف هاة كل تحذّر للعنثر تزجوتها

안전을 위한 주의사항

경고!

이 경고 기호는 위험이 있음을 알려 줍니다. 작업자의 신체에 부상을 야기 할 수 있는 상태에 있게 됩니다. 모든 장비에 대한 작업을 수행하기 전에 전기회로와 관련된 위험요소들을 확인하시고 사전에 사고를 방지할 수 있도록 표준 작업절차를 준수해 주시기 바랍니다.

해당 번역문을 찾기 위해 각 경고의 마지막 부분에 제공된 경고문 번호를 참조하십시오

BELANGRIJKE VEILIGHEIDSINSTRUCTIES

Dit waarschuwings symbool betekent gevaar. U verkeert in een situatie die lichamelijk letsel kan veroorzaken. Voordat u aan enige apparatuur gaat werken, dient u zich bewust te zijn van de bij een elektrische installatie betrokken risico's en dient u op de hoogte te zijn van de standaard procedures om ongelukken te voorkomen. Gebruik de nummers aan het eind van elke waarschuwing om deze te herleiden naar de desbetreffende locatie.

BEWAAR DEZE INSTRUCTIES

Installation Instructions



Warning! Read the installation instructions before connecting the system to the power source.

設置手順書

システムを電源に接続する前に、設置手順書をお読み下さい。

警告

将此系统连接电源前,请先阅读安装说明。

警告

將系統與電源連接前,請先閱讀安裝說明。

Warnung

Vor dem Anschließen des Systems an die Stromquelle die Installationsanweisungen lesen.

¡Advertencia!

Lea las instrucciones de instalación antes de conectar el sistema a la red de alimentación.

Attention

Avant de brancher le système sur la source d'alimentation, consulter les directives d'installation.

יש לקרוא את הוראות התקנה לפני חיבור המערכת למקור מתח.

اقر إرشادات التركيب قبل توصيل النظام إلى مصدر للطاقة

시스템을 전원에 연결하기 전에 설치 안내를 읽어주십시오.

Waarschuwing

Raadpleeg de installatie-instructies voordat u het systeem op de voedingsbron aansluit.

Circuit Breaker



Warning! This product relies on the building's installation for short-circuit (overcurrent) protection. Ensure that the protective device is rated not greater than: 250 V, 20 A.

サーキット・ブレーカー

この製品は、短絡(過電流)保護装置がある建物での設置を前提としています。

保護装置の定格が250V、20Aを超えないことを確認下さい。

警告

此产品的短路(过载电流)保护由建筑物的供电系统提供,确保短路保护设备的额定电流不大于 250V,20A。

警告

此產品的短路(過載電流)保護由建築物的供電系統提供,確保短路保護設備的額定電流不大於 250V,20A。

Warnung

Dieses Produkt ist darauf angewiesen, dass im Gebäude ein Kurzschluss- bzw. Überstromschutz installiert ist. Stellen Sie sicher, dass der Nennwert der Schutzvorrichtung nicht mehr als: 250 V, 20 A beträgt.

¡Advertencia!

Este equipo utiliza el sistema de protección contra cortocircuitos (o sobrecorrientes) del edificio. Asegúrese de que el dispositivo de protección no sea superior a: 250 V, 20 A.

Attention

Pour ce qui est de la protection contre les courts-circuits (surtension), ce produit dépend de l'installation électrique du local. Vérifiez que le courant nominal du dispositif de protection n'est pas supérieur à :250 V, 20 A.

מוצר זה מסתמך על הגנה המותקנת במבנים למניעת קצר חשמלי. יש לוודא כי

המכשיר המגן מפני הקצר החשמלי הוא לא יותר מ-250V, 20A

هذا المنتج يعتمد على معدات الحماية من الدوائر القصيرة التي تم تثبيتها في

المبنى

تأكد من أن تقييم الجهاز الوقائي ليس أكثر من : 20A, 250V

경고!

이 제품은 전원의 단락(과전류)방지에 대해서 전적으로 건물의 관련 설비에 의존합니다. 보호장치의 정격이 반드시 250V(볼트), 20A(암페어)를 초과하지 않도록 해야 합니다.

Waarschuwing

Dit product is afhankelijk van de kortsluitbeveiliging (overspanning) van uw elektrische installatie. Controleer of het beveiligde apparaat niet groter gedimensioneerd is dan 250V, 20A.

Power Disconnection Warning

Warning! The system must be disconnected from all sources of power and the power cord removed from the power supply module(s) before accessing the chassis interior to install or remove system components (except for hot-swap components).

電源切断の警告

システムコンポーネントの取り付けまたは取り外しのために、シャーシ内部にアクセスするには、システムの電源はすべてのソースから切断され、電源コードは電源モジュールから取り外す必要があります。

警告

在你打开机箱并安装或移除内部器件前,必须将系统完全断电,并移除电源线。

警告

在您打開機殼安裝或移除內部元件前,必須將系統完全斷電,並移除電源線。

Warnung

Das System muss von allen Quellen der Energie und vom Netzanschlusskabel getrennt sein, das von den Spg.Versorgungsteilmodulen entfernt wird, bevor es auf den Chassisinnenraum zurückgreift, um Systemsbestandteile anzubringen oder zu entfernen.

¡Advertencia!

El sistema debe ser disconnected de todas las fuentes de energía y del cable eléctrico quitado de los módulos de fuente de alimentación antes de tener acceso el interior del chasis para instalar o para quitar componentes de sistema.

Attention

Le système doit être débranché de toutes les sources de puissance ainsi que de son cordon d'alimentation secteur avant d'accéder à l'intérieur du châssis pour installer ou enlever des composants de système.

אזהרה מפני ניתוק חשמלי

אזהרה!

יש לנתק את המערכת מכל מקורות החשמל ויש להסיר את כבל החשמלי מהספק לפני גישה לחלק הפנימי של המארז לצורך התקנת או הסרת רכיבים.

يجب فصل انظماو من جميع مصادر انطاقت وإزانت سهك انكهرباء من وحدة امداد انطاقت قيم

انصلل إلى انمناطق انداخهيت نههيكم ننتشيج أو إزانت مكنناث الجهاز

경고!

시스템에 부품들을 장착하거나 제거하기 위해서는 새시 내부에 접근하기 전에 반드시 전원 공급장치로부터 연결되어있는 모든 전원과 전기코드를 분리해주어야 합니다.

Waarschuwing

Voordat u toegang neemt tot het binnenwerk van de behuizing voor het installeren of verwijderen van systeem onderdelen, dient u alle spanningsbronnen en alle stroomkabels aangesloten op de voeding(en) van de behuizing te verwijderen

Equipment Installation



Warning! Only authorized personnel and qualified service persons should be allowed to install, replace, or service this equipment.

機器の設置

トレーニングを受け認定された人だけがこの装置の設置、交換、またはサービスを許可されています。

警告

只有经过培训且具有资格的人员才能进行此设备的安装、更换和维修。

警告

只有經過受訓且具資格人員才可安裝、更換與維修此設備。

Warnung

Nur autorisiertes Personal und qualifizierte Servicetechniker dürfen dieses Gerät installieren, austauschen oder warten.

¡Advertencia!

Sólo el personal autorizado y el personal de servicio calificado deben poder instalar, reemplazar o dar servicio a este equipo.

Attention

Seul le personnel autorisé et le personnel de maintenance qualifié doivent être autorisés à installer, remplacer ou entretenir cet équipement.

אזהרה!

יש לאפשר רק צוות מורשה ואנשי שירות מוסמכים להתקין, להחליף או לטפל בצידוד זה

ينبغي السماح فقط للموظفين المعتمدين وأفراد الخدمة المؤهلين بتركيب هذا الجهاز أو استبداله أو صيانته

경고!

승인된 직원과 자격을 갖춘 서비스 담당자만이 이 장비를 설치, 교체 또는 서비스할 수 있습니다.

Waarschuwing

Alleen geautoriseerd personeel en gekwalificeerd onderhoudspersoneel mag deze apparatuur installeren, vervangen of onderhouden.

Restricted Area



Warning! This unit is intended for installation in restricted access areas. A restricted access area can be accessed only through the use of a special tool, lock and key, or other means of security. (This warning does not apply to workstations).

アクセス制限区域

このユニットは、アクセス制限区域に設置されることを想定しています。

アクセス制限区域は、特別なツール、鍵と錠前、その他のセキュリティの手段を用いてのみ出入りが可能です。

警告

此部件应安装在限制进出的场所，限制进出的场所指只能通过使用特殊工具、锁和钥匙或其它安全手段进出的场所。

警告

此装置僅限安裝於進出管制區域，進出管制區域係指僅能以特殊工具、鎖頭及鑰匙或其他安全方式才能進入的區域。

Warnung

Diese Einheit ist zur Installation in Bereichen mit beschränktem Zutritt vorgesehen. Der Zutritt zu derartigen Bereichen ist nur mit einem Spezialwerkzeug, Schloss und Schlüssel oder einer sonstigen Sicherheitsvorkehrung möglich.

¡Advertencia!

Esta unidad ha sido diseñada para instalación en áreas de acceso restringido. Sólo puede obtenerse acceso a una de estas áreas mediante la utilización de una herramienta especial, cerradura con llave u otro medio de seguridad.

Attention

Cet appareil doit être installée dans des zones d'accès réservés. L'accès à une zone d'accès réservé n'est possible qu'en utilisant un outil spécial, un mécanisme de verrouillage et une clé, ou tout autre moyen de sécurité.

אזור עם גישה מוגבלת

אזהרה!

יש להתקין את היחידה באזורים שיש בהם הגבלת גישה. הגישה ניתנת בעזרת כלי אבטחה בלבד (מפתח, מנעול וכד.).

اتخصيص هذه انحدة نترك بها ف مناطق محظورة تم .

ممكن انصلل إن منطقت محظورة فقط من خلال استخدام أداة خاصت،

أو أوس هُت أخري نلاأما ققم ومفتاح

경고!

이 장치는 접근이 제한된 구역에 설치하도록 되어있습니다. 특수도구, 잠금 장치 및 키, 또는 기타 보안 수단을 통해서만 접근 제한 구역에 들어갈 수 있습니다.

Waarschuwing

Dit apparaat is bedoeld voor installatie in gebieden met een beperkte toegang. Toegang tot dergelijke gebieden kunnen alleen verkregen worden door gebruik te maken van speciaal gereedschap, slot en sleutel of andere veiligheidsmaatregelen.

Battery Handling



CAUTION There is risk of explosion if the battery is replaced by an incorrect type. Replace the battery only with the same or equivalent type recommended by the manufacturer. Dispose of used batteries according to the manufacturer's instructions.

電池の取り扱い

バッテリーを間違ったタイプに交換すると爆発の危険があります。交換する電池はメーカーが推奨する型、または同等のものを使用下さい。使用済電池は製造元の指示に従って処分して下さい。

警告

如果更换的电池类型不正确。请只使用同类电池或制造商推荐的功能相当的电池更换原有电池。请按制造商的说明处理废旧电池。

警告

如果更換的電池類型不正確。請使用製造商建議之相同或功能相當的電池更換原有電池。請按照製造商的說明指示處理廢棄舊電池。

WARNUNG

Es besteht Explosionsgefahr, wenn die Batterie durch einen falschen Typ ersetzt wird. Ersetzen Sie die Batterie nur durch den gleichen oder vom Hersteller empfohlenen Batterietyp. Entsorgen Sie die benutzten Batterien nach den Anweisungen des Herstellers.

ADVERTENCIA

Existe riesgo de explosión si la batería se reemplaza por un tipo incorrecto. Reemplazar la batería exclusivamente con el mismo tipo o el equivalente recomendado por el fabricante. Desechar las baterías gastadas según las instrucciones del fabricante.

ATTENTION

Il existe un risque d'explosion si la batterie est remplacée par un type incorrect. Ne la remplacer que par une pile de type semblable ou équivalent, recommandée par le fabricant. Jeter les piles usagées conformément aux instructions du fabricant.

אזהרה!

קיימת סכנת פיצוץ אם הסוללה תוחלף בסוג שגוי. יש להחליף את הסוללה בסוג התואם מחברת יצרן מומלצת. סילוק הסוללות המשומשות יש לבצע לפי הוראות היצרן.

هناك خطر الانفجار إذا تم استبدال البطارية بنوع غير صحيح

استبدال البطارية

فقط بنفس النوع أو ما يعادلها مما أوصت به الشركة المصنعة

جخلص من البطاريات المسحمة وفقاً لتعليمات الشركة الصانعة

경고!

배터리를 잘못된 종류로 교체하면 폭발의 위험이 있습니다. 기존 배터리와 동일하거나 제조사에서 권장하는 동등한 종류의 배터리로만 교체해야 합니다. 제조사의 안내에 따라 사용된 배터리를 처리하여 주십시오.

WAARSCHUWING

Er bestaat explosiegevaar als de batterij wordt vervangen door een verkeerd type. Vervang de batterij slechts met hetzelfde of een equivalent type die door de fabrikant aanbevolen wordt. Gebruikte batterijen dienen overeenkomstig fabrieksvoorschriften afgevoerd te worden.

Redundant Power Supplies

Warning! This unit might have more than one power supply connection. All connections must be removed to de-energize the unit.

冗長電源装置

このユニットは複数の電源装置が接続されている場合があります。

ユニットの電源を切るためには、すべての接続を取り外さなければなりません。

警告

此部件连接的电源可能不止一个，必须将所有电源断开才能停止给该部件供电。

警告

此装置连接的电源可能不只一个，必须切断所有电源才能停止对该装置的供电。

Warnung

Dieses Gerät kann mehr als eine Stromzufuhr haben. Um sicherzustellen, dass der Einheit kein Strom zugeführt wird, müssen alle Verbindungen entfernt werden.

¡Advertencia!

Puede que esta unidad tenga más de una conexión para fuentes de alimentación. Para cortar por completo el suministro de energía, deben desconectarse todas las conexiones.

Attention

Cette unité peut avoir plus d'une connexion d'alimentation. Pour supprimer toute tension et tout courant électrique de l'unité, toutes les connexions d'alimentation doivent être débranchées.

אם קיים יותר מספק אחד

אזהרה!

ליחידה יש יותר מחיבור אחד של ספק. יש להסיר את כל החיבורים על מנת לרוקן

את היחידה.

قد يكون لهذا الجهاز عدة اتصالات بوحدات امداد الطاقة .

يجب إزالة كافة الاتصالات لعزل الوحدة عن الكهرباء

경고!

이 장치에는 한 개 이상의 전원 공급 단자가 연결되어 있을 수 있습니다. 이 장치에 전원을 차단하기 위해서는 모든 연결 단자를 제거해야만 합니다.

Waarschuwing

Deze eenheid kan meer dan één stroomtoevoeraansluiting bevatten. Alle aansluitingen dienen verwijderd te worden om het apparaat stroomloos te maken.

Backplane Voltage



Warning! Hazardous voltage or energy is present on the backplane when the system is operating. Use caution when servicing.

バックプレーンの電圧

システムの稼働中は危険な電圧または電力が、バックプレーン上にかかっています。

修理する際には注意ください。

警告

当系统正在进行时,背板上有很危险的电压或能量,进行维修时务必小心。

警告

當系統正在進行時，背板上有危險的電壓或能量，進行維修時務必小心。

Warnung

Wenn das System in Betrieb ist, treten auf der Rückwandplatine gefährliche Spannungen oder Energien auf. Vorsicht bei der Wartung.

¡Advertencia!

Cuando el sistema está en funcionamiento, el voltaje del plano trasero es peligroso. Tenga cuidado cuando lo revise.

Attention

Lorsque le système est en fonctionnement, des tensions électriques circulent sur le fond de panier. Prendre des précautions lors de la maintenance.

מתח בפנל האחורי

אזהרה!

קיימת סכנת מתח בפנל האחורי בזמן תפעול המערכת. יש להיזהר במהלך

העבודה.

هناك خطر من التيار الكهربائي أو الطاقة المخزنة على اللوحة

عندما يكون النظام يعمل كه حذرا عند خدمة هذا الجهاز

경고!

시스템이 동작 중일 때 후면판 (Backplane)에는 위험한 전압이나 에너지가 발생 합니다. 서비스 작업 시 주의하십시오.

Waarschuwing

Een gevaarlijke spanning of energie is aanwezig op de backplane wanneer het systeem in gebruik is. Voorzichtigheid is geboden tijdens het onderhoud.

Comply with Local and National Electrical Codes



Warning! Installation of the equipment must comply with local and national electrical codes.

地方および国の電気規格に準拠

機器の取り付けはその地方および国の電気規格に準拠する必要があります。

警告

设备安装必须符合本地与本国电气法规。

警告

設備安裝必須符合本地與本國電氣法規。

Warnung

Die Installation der Geräte muss den Sicherheitsstandards entsprechen.

¡Advertencia!

La instalacion del equipo debe cumplir con las normas de electricidad locales y nacionales.

Attention

L'équipement doit être installé conformément aux normes électriques nationales et locales.

תיאום חוקי החשמל הארצי

אזהרה!

התקנת הציוד חייבת להיות תואמת לחוקי החשמל המקומיים והארציים.

تركيب المعدات الكهربائية يجب أن يمتثل للقوانين المحلية والنظية المتعلقة

بالكهرباء

경고!

현 지역 및 국가의 전기 규정에 따라 장비를 설치해야 합니다.

Waarschuwing

Bij installatie van de apparatuur moet worden voldaan aan de lokale en nationale elektriciteitsvoorschriften.

Product Disposal



Warning! Ultimate disposal of this product should be handled according to all national laws and regulations.

製品の廃棄

この製品を廃棄処分する場合、国の関係する全ての法律・条例に従い処理する必要があります。

警告

本产品的废弃处理应根据所有国家的法律和规章进行。

警告

本產品的廢棄處理應根據所有國家的法律和規章進行。

Warnung

Die Entsorgung dieses Produkts sollte gemäß allen Bestimmungen und Gesetzen des Landes erfolgen.

¡Advertencia!

Al deshacerse por completo de este producto debe seguir todas las leyes y reglamentos nacionales.

Attention

La mise au rebut ou le recyclage de ce produit sont généralement soumis à des lois et/ou directives de respect de l'environnement. Renseignez-vous auprès de l'organisme compétent.

סילוק המוצר

אזהרה!

סילוק סופי של מוצר זה חייב להיות בהתאם להנחיות וחוקי המדינה.

عند التخلص النهائي من هذا المنتج ينبغي التعامل معه وفقا لجميع القوانين واللوائح الوطنية

경고!

이 제품은 해당 국가의 관련 법규 및 규정에 따라 폐기되어야 합니다.

Waarschuwing

De uiteindelijke verwijdering van dit product dient te geschieden in overeenstemming met alle nationale wetten en reglementen.

Fan Warning



Warning! Hazardous moving parts. Keep away from moving fan blades. The fans might still be turning when you remove the fan assembly from the chassis. Keep fingers, screwdrivers, and other objects away from the openings in the fan assembly's housing



ファンの警告

警告！回転部品に注意。運転中は回転部(羽根)に触れないでください。シャーシから冷却ファン装置を取り外した際、ファンがまだ回転している可能性があります。ファンの開口部に、指、ドライバー、およびその他のものを近づけないで下さい。

警告!

警告! 危险的可移动性零件。请务必与转动的风扇叶片保持距离。当您从机架移除风扇装置, 风扇可能仍在转动。小心不要将手指、螺丝起子和其他物品太靠近风扇

警告

危險的可移動性零件。請務必與轉動的風扇葉片保持距離。當您從機架移除風扇裝置, 風扇可能仍在轉動。小心不要將手指、螺絲起子和其他物品太靠近風扇。

Warnung

Gefährlich Bewegende Teile. Von den bewegenden Lüfterblätter fern halten. Die Lüfter drehen sich u. U. noch, wenn die Lüfterbaugruppe aus dem Chassis genommen wird. Halten Sie Finger, Schraubendreher und andere Gegenstände von den Öffnungen des Lüftergehäuses entfernt.

¡Advertencia!

Riesgo de piezas móviles. Mantener alejado de las aspas del ventilador. Los ventiladores podran dar vuelta cuando usted quite el montaje del ventilador del chasis. Mantenga los dedos, los destornilladores y todos los objetos lejos de las aberturas del ventilador.

Attention

Pieces mobiles dangereuses. Se tenir a l'écart des lames du ventilateur Il est possible que les ventilateurs soient toujours en rotation lorsque vous retirerez le bloc ventilateur du châssis. Prenez garde à ce que doigts, tournevis et autres objets soient éloignés du logement du bloc ventilateur.

אזהרה!

חלקים נעים מסוכנים. התרחק מלהבי המאוורר בפעולהכאשר מסירים את חלקי המאוורר מהמארז, יתכן והמאווררים עדיין עובדים. יש להרחיק למרחק בטוח את האצבעות וכלי עבודה שונים מהפתחים בתוך המאוורר

تحذير! أجزاء متحركة خطيرة. ابتعد عن شفرات المروحة المتحركة. من الممكن أن المراوح لا تزال تدور عند إزالة كتلة المروحة من الهيكل يجب إبقاء الأصابع ومفكات البراغي وغيرها من الأشياء بعيدا عن الفتحات في كتلة المروحة.

경고!

움직이는 위험한 부품. 회전하는 송풍 날개에 접근하지 마세요. 새시로부터 팬 조립품을 제거할 때 팬은 여전히 회전하고 있을 수 있습니다. 팬 조립품 외관의 열려있는 부분들로부터 손가락 및 스크류드라이버, 다른 물체들이 가까이 하지 않도록 배치해 주십시오.

Waarschuwing

Gevaarlijk bewegende onderdelen. Houd voldoende afstand tot de bewegende ventilatorbladen. Het is mogelijk dat de ventilator nog draait tijdens het verwijderen van het ventilatorsamenstel uit het chassis. Houd uw vingers, schroevendraaiers en eventuele andere voorwerpen uit de buurt van de openingen in de ventilatorbehuizing.

Power Cable and AC Adapter



Warning! When installing the product, use the provided or designated connection cables, power cables and AC adaptors. Using any other cables and adaptors could cause a malfunction or a fire. Electrical Appliance and Material Safety Law prohibits the use of UL or CSA -certified cables (that have UL/CSA shown on the cord) for any other electrical devices than products designated by Supermicro only.

電源コードとACアダプター

製品を設置する場合、提供または指定および購入された接続ケーブル、電源コードとACアダプターを該当する地域の条例や安全基準に適合するコードサイズやプラグと共に使用下さい。他のケーブルやアダプタを使用すると故障や火災の原因になることがあります。

電気用品安全法は、ULまたはCSA認定のケーブル(UL/CSAマークがコードに表記)をSupermicroが指定する製品以外に使用することを禁止しています。

警告

安裝此產品時,請使用本身提供的或指定的或採購的連接線,電源線和電源適配器,包含遵照當地法規和安全要求的合規的電源線尺寸和插頭.使用其它線材或適配器可能會引起故障或火災。除了 **Supermicro** 所指定的產品,電氣用品和材料安全法律規定禁止使用未經 **UL** 或 **CSA** 認證的線材。(線材上會顯示 **UL/CSA** 符號)。

警告

安裝此產品時,請使用本身提供的或指定的或採購的連接線,電源線和電源適配器,包含遵照當地法規和安全要求的合規的電源線尺寸和插頭.使用其它線材或適配器可能會引起故障或火災。除了 **Supermicro** 所指定的產品,電氣用品和材料安全法律規定禁止使用未經 **UL** 或 **CSA** 認證的線材。(線材上會顯示 **UL/CSA** 符號)。

Warnung

Nutzen Sie beim Installieren des Produkts ausschließlich die von uns zur Verfügung gestellten Verbindungskabeln, Stromkabeln und/oder Adapter, die Ihre örtlichen Sicherheitsstandards einhalten. Der Gebrauch von anderen Kabeln und Adapter können Fehlfunktionen oder Feuer verursachen. Die Richtlinien untersagen das Nutzen von UL oder CAS zertifizierten Kabeln (mit UL/CSA gekennzeichnet), an Geräten oder Produkten die nicht mit Supermicro gekennzeichnet sind.

¡Advertencia!

Cuando instale el producto, utilice la conexión provista o designada o procure cables, Cables de alimentación y adaptadores de CA que cumplan con los códigos locales y los requisitos de seguridad, incluyendo el tamaño adecuado del cable y el enchufe. El uso de otros cables y adaptadores podría causar un mal funcionamiento o un incendio. La Ley de Seguridad de Aparatos Eléctricos y de Materiales prohíbe El uso de cables certificados por UL o CSA (que tienen el certificado UL / CSA en el código) para cualquier otros dispositivos eléctricos que los productos designados únicamente por Supermicro.

Attention

Lors de l'installation du produit, utilisez les câbles de connection fournis ou désigné ou achetez des câbles, câbles de puissance et adaptateurs respectant les normes locales et les conditions de sécurité y compris les tailles de câbles et les prises électriques appropriées. L'utilisation d'autres câbles et adaptateurs peut provoquer un dysfonctionnement ou un incendie. Appareils électroménagers et la Loi sur la Sécurité Matériel interdit l'utilisation de câbles certifiés- UL ou CSA (qui ont UL ou CSA indiqué sur le code) pour tous les autres appareils électriques sauf les produits désignés par Supermicro seulement.

AC ימאתמו םיילמשח םילבכ

הרהזא!

ךרוצל ומאתוה וא ושכרנ רשא AC םימאתמו םיקפס, םילבכב שמתשהל שי, רצומה תא םיניקתמ רשאכ לכב שומיש . עקתהו לבכה לש הנוכנ הדימ ללוכ, תוימוקמה תוחיטבה תושירדל ומאתוה רשאו, הנקתהה למשחה ירישכמב שומישה יקוחל סאתהב . ילמשח רצק וא הלקתל םורגל לולע, רחא גוסמ סאתמ וא לבכ לש דוק םהילע עיפומ רשאכ) CSA- ב או UL - ב םיכסומה םילבכב שמתשהל רוסיא םייק, תוחיטבה יקוחו דבלב Supermicro י"ע סאתוה רשא רצומב קר אלא, רחא ילמשח רצומ לכ רובע (UL/CSA).

תאלבאקלא ארשב מץ וא םדדחמלא וא םרפוטמלא תאליסוטלא מאדחטסאב מץ, גתנמלא בייקרת דנע

כלז יפ אמב םילחמלא םאלסלא תאבלטמו נינאוקב מאז תלאלא עמ דדרתמלא ראיטלא תאלוחמו םינאבר הכלא

קירח וא לטע יפ בייסטי דץ ברחא תאלוחמו תאלבאק יא מאדחטסא . מילסלא סבאקלאו לטומלא מנג .

CSA וא UL לביץ נמ םדמטמלא תאלבאקלא מאדחטסא תאדעמלאו םינאבר הכלא עז הגאלל םאלסלא נונאק רזחי

Supermicro לביץ נמ םדדחמלאו םינעמלא תאגתנמלא רינג ברחא תאדעמ יא עמ (UL/CSA) םעלע למחט יטלאו .

전원 케이블 및 AC 어댑터

경고! 제품을 설치할 때 현지 코드 및 적절한 굵기의 코드와 플러그를 포함한 안전 요구 사항을 준수하여 제공되거나 지정된 연결 혹은 구매 케이블, 전원 케이블 및 AC 어댑터를 사용하십시오.

다른 케이블이나 어댑터를 사용하면 오작동이나 화재가 발생할 수 있습니다. 전기 용품 안전법은 UL 또는 CSA 인증 케이블 (코드에 UL / CSA가 표시된 케이블)을 Supermicro 가 지정한 제품 이외의 전기 장치에 사용하는 것을 금지합니다.

Stroomkabel en AC-Adapter

Waarschuwing! Bij het aansluiten van het Product uitsluitend gebruik maken van de geleverde Kabels of een andere geschikte aan te schaffen Aansluitmethode, deze moet altijd voldoen aan de lokale voorschriften en veiligheidsnormen, inclusief de juiste kabeldikte en stekker. Het gebruik van niet geschikte Kabels en/of Adapters kan een storing of brand veroorzaken. Wetgeving voor Elektrische apparatuur en Materiaalveiligheid verbied het gebruik van UL of CSA -gecertificeerde Kabels (met UL/CSA in de code) voor elke andere toepassing dan de door Supermicro hiervoor beoogde Producten.

Appendix C:

System Specifications

Processors

Supports dual Intel® Xeon® 6700-series processors with E-cores with a thermal design power (TDP) up to 330 W

Chipset

System on Chip

BIOS

512 MB SPI Flash ROM

Memory

Slot Count: 16 DIMM slots

Max Memory (1DPC): Up to 2 TB of DDR5 RDIMM memory with speeds of up to 6400 MHz

Storage Drives

Default: eight total bays

Four front hot-swap 3.5" NVMe*/SAS*/SATA drive bays

Four front hot-swap 3.5" SAS*/SATA drive bays

Two M.2 PCIe 5.0 x4 NVMe slots (M-key)

One slim DVD bay (optional)

*NVMe/SAS support may require additional storage controller and/or cables

PCIe Expansion Slots

Four PCIe 5.0 x16 slots (low profile)

Two PCIe 5.0 x8 slots (low profile)

Input/Output

Two 10GBASE-T ports

One dedicated management LAN port (BMC LAN)

One VGA port (rear)

Four rear USB 3.0 ports

Two front USB 3.0 ports

Two COM ports (one rear, one front)

Motherboard

X14DBI-T; (WxHxD) 12.1" x 13.05" (30.74 x 33.15 cm)

Chassis

CSE-825BTS-R1K23LPP1; (WxHxD) 17.2" x 3.5" x 25.5" (336 x 76 x 40 mm)

System Cooling

Three heavy-duty fans with optimal fan speed control

One air shroud

Power Supply

Two 1200 W high-efficiency Titanium Level digital power supply

Optional: 1050 W DC power module

Operating Environment

Operating Temperature: 10° to 35°C (50° to 95° F)

Non-operating Temperature: -30°C to 60°C (-40°F to 158°F)

Operating Relative Humidity: 8% to 80% (non-condensing)

Non-operating Relative Humidity: 8% to 90% (non-condensing)

Regulatory Compliance

FCC, ICES, CE, UKCA, VCCI, RCM, NRTL, CB

Certified Safety Models

825-R12X14, 825-12, 825-R11DX14, 825-11D

Applied Directives, Standards**Directives:**

EMC/EMI: 2014/30/EU (EMC Directive)
Electromagnetic Compatibility Regulations 2016
FCC Part 15 Subpart B
ICES-003
VCCI-CISPR 32
AS/NZS CISPR 32
CISPR 32
CISPR 35
BS/EN 55032
BS/EN 55035
BS/EN 61000-3-2
BS/EN 61000-3-3
BS/EN 61000-4-2
BS/EN 61000-4-3
BS/EN 61000-4-4
BS/EN 61000-4-5
BS/EN 61000-4-6
BS/EN 61000-4-8
BS/EN 61000-4-11

Environment:

Delegated Directive (EU) 2015/863
Directive 2011/65/EU (RoHS)
REACH Regulation EC 1907/2006
WEEE Directive 2012/19/EU
California Proposition 65

Product Safety:

2014/35/EU (LVD Directive)
UL/CSA 62368-1 (USA and Canada)
Electrical Equipment (Safety) Regulations 2016
IEC/BS/EN 62368-1

Perchlorate Warning

California Best Management Practices Regulations for Perchlorate Materials: This Perchlorate warning applies only to products containing CR (Manganese Dioxide) Lithium coin cells. Perchlorate Material-special handling may apply. See

<https://www.dtsc.ca.gov/hazardouswaste/perchlorate>

この装置は、クラスA機器です。この装置を住宅環境で使用すると電波妨害を引き起こすことがあります。この場合には使用者が適切な対策を講ずるよう要求されることがあります。

VCCI - A

Appendix C:

RoHS Certification

限用物質含有情況標示聲明書

Declaration of the Presence Condition of the Restricted Substances Marking

設備名稱: 伺服器/ Server 型號 (型式) : 825-R12X14 Equipment name Type designation (Type) (系列型號: 825-12, SYS-622B-TRT)						
單元 Unit	限用物質及其化學符號 Restricted substances and its chemical symbols					
	鉛Lead (Pb)	汞Mercury (Hg)	鎘Cadmium (Cd)	六價鉻 Hexavalent chromium (Cr ⁺⁶)	多溴聯苯 Polybrominated biphenyls (PBB)	多溴二苯醚 Polybrominated diphenyl ethers (PBDE)
機殼 (Chassis)	○	○	○	○	○	○
機殼風扇 (Chassis Fan)	—	○	○	○	○	○
線材 (Cable)	○	○	○	○	○	○
主機板 (Motherboard)	—	○	○	○	○	○
電源供應器 (Power Supply)	—	○	○	○	○	○
電源背板 (PDB)	—	○	○	○	○	○
硬碟 (HDD)	—	○	○	○	○	○
備考1. “超出0.1 wt %” 及 “超出0.01 wt %” 係指限用物質之百分比含量超出百分比含量基準值。 Note 1 : “Exceeding 0.1 wt %” and “exceeding 0.01 wt %” indicate that the percentage content of the restricted substance exceeds the reference percentage value of presence condition.						
備考2. “○” 係指該項限用物質之百分比含量未超出百分比含量基準值。 Note 2 : “○” indicates that the percentage content of the restricted substance does not exceed the percentage of reference value of presence.						
備考3. “—” 係指該項限用物質為排除項目。 Note 3 : The “—” indicates that the restricted substance corresponds to the exemption.						

警告：為避免電磁干擾，本產品不應安裝或使用於住宅環境。

輸入額定：

100-127V ~, 60-50Hz, 12-10A (x2)

200-240V ~, 60-50Hz, 8.5-7A (x2)

*使用者不能任意拆除或替換內部配備

*報驗義務人之姓名或名稱：美超微電腦股份有限公司

*報驗義務人之地址：新北市中和區建一路 150 號 3 樓