



STORAGE A+ SERVER<sup>®</sup>  
ASG -2015S-E1CR24H  
ASG -2015S-E1CR24L



USER'S MANUAL

Revision 1.0

The information in this User's Manual has been carefully reviewed and is believed to be accurate. The vendor assumes no responsibility for any inaccuracies that may be contained in this document, and makes no commitment to update or to keep current the information in this manual, or to notify any person or organization of the updates. Please Note: For the most up-to-date version of this manual, please see our website at [www.supermicro.com](http://www.supermicro.com).

Super Micro Computer, Inc. ("Supermicro") reserves the right to make changes to the product described in this manual at any time and without notice. This product, including software and documentation, is the property of Supermicro and/or its licensors, and is supplied only under a license. Any use or reproduction of this product is not allowed, except as expressly permitted by the terms of said license.

IN NO EVENT WILL Super Micro Computer, Inc. BE LIABLE FOR DIRECT, INDIRECT, SPECIAL, INCIDENTAL, SPECULATIVE OR CONSEQUENTIAL DAMAGES ARISING FROM THE USE OR INABILITY TO USE THIS PRODUCT OR DOCUMENTATION, EVEN IF ADVISED OF THE POSSIBILITY OF SUCH DAMAGES. IN PARTICULAR, SUPER MICRO COMPUTER, INC. SHALL NOT HAVE LIABILITY FOR ANY HARDWARE, SOFTWARE, OR DATA STORED OR USED WITH THE PRODUCT, INCLUDING THE COSTS OF REPAIRING, REPLACING, INTEGRATING, INSTALLING OR RECOVERING SUCH HARDWARE, SOFTWARE, OR DATA.

Any disputes arising between manufacturer and customer shall be governed by the laws of Santa Clara County in the State of California, USA. The State of California, County of Santa Clara shall be the exclusive venue for the resolution of any such disputes. Supermicro's total liability for all claims will not exceed the price paid for the hardware product.

FCC Statement: This equipment has been tested and found to comply with the limits for a Class A or Class B digital device pursuant to Part 15 of the FCC Rules. These limits are designed to provide reasonable protection against harmful interference when the equipment is operated in industrial environment for Class A device or in residential environment for Class B device. This equipment generates, uses, and can radiate radio frequency energy and, if not installed and used in accordance with the manufacturer's instruction manual, may cause harmful interference with radio communications. Operation of this equipment in a residential area is likely to cause harmful interference, in which case you will be required to correct the interference at your own expense.

California Best Management Practices Regulations for Perchlorate Materials: This Perchlorate warning applies only to products containing CR (Manganese Dioxide) Lithium coin cells. "Perchlorate Material-special handling may apply. See [www.dtsc.ca.gov/hazardouswaste/perchlorate](http://www.dtsc.ca.gov/hazardouswaste/perchlorate)".



WARNING: This product can expose you to chemicals including lead, known to the State of California to cause cancer and birth defects or other reproductive harm. For more information, go to [www.P65Warnings.ca.gov](http://www.P65Warnings.ca.gov).

The products sold by Supermicro are not intended for and will not be used in life support systems, medical equipment, nuclear facilities or systems, aircraft, aircraft devices, aircraft/emergency communication devices or other critical systems whose failure to perform be reasonably expected to result in significant injury or loss of life or catastrophic property damage. Accordingly, Supermicro disclaims any and all liability, and should buyer use or sell such products for use in such ultra-hazardous applications, it does so entirely at its own risk. Furthermore, buyer agrees to fully indemnify, defend and hold Supermicro harmless for and against any and all claims, demands, actions, litigation, and proceedings of any kind arising out of or related to such ultra-hazardous use or sale.

Manual Revision 1.0

Release Date: February 13, 2024

Unless you request and receive written permission from Super Micro Computer, Inc., you may not copy any part of this document. Information in this document is subject to change without notice. Other products and companies referred to herein are trademarks or registered trademarks of their respective companies or mark holders.

Copyright © 2024 by Super Micro Computer, Inc.  
All rights reserved.

**Printed in the United States of America**

# Preface

## About this Manual

This manual is written for professional system integrators and PC technicians. It provides information for the installation and use of the server. Installation and maintenance should be performed by certified service technicians only.

Please refer to the ASG -2015S-E1CR24H/ASG -2015S-E1CR24L server specifications page on our website for updates on supported memory, processors and operating systems (<http://www.supermicro.com>).

## Notes

For your system to work properly, please follow the links below to download all necessary drivers/utilities and the user's manual for your server.

- Supermicro product manuals: <http://www.supermicro.com/support/manuals/>
- Product drivers and utilities: <https://www.supermicro.com/wdl>
- Product safety info: [http://www.supermicro.com/about/policies/safety\\_information.cfm](http://www.supermicro.com/about/policies/safety_information.cfm)

If you have any questions, please contact our support team at:  
[support@supermicro.com](mailto:support@supermicro.com)

This manual may be periodically updated without notice. Please check the Supermicro website for possible updates to the manual revision level.

## Secure Data Deletion

A secure data deletion tool designed to fully erase all data from storage devices can be found on our website: [https://www.supermicro.com/about/policies/disclaimer.cfm?url=/wdl/utility/Lot9\\_Secure\\_Data\\_Deletion\\_Utility/](https://www.supermicro.com/about/policies/disclaimer.cfm?url=/wdl/utility/Lot9_Secure_Data_Deletion_Utility/)

## Warnings

Special attention should be given to the following symbols used in this manual.



**Warning!** Indicates important information given to prevent equipment/property damage or personal injury.



**Warning!** Indicates high voltage may be encountered when performing a procedure.

# Contents

## **Chapter 1 Introduction**

1.1 Overview.....	9
Models.....	9
1.2 System Features.....	10
Front View.....	10
Drive Carrier Indicators.....	11
Control Panel.....	12
Rear View.....	13
1.3 System Architecture.....	16
1.4 Motherboard Layout.....	18
Quick Reference Table.....	19
Motherboard Block Diagram.....	20

## **Chapter 2 Server Installation**

2.1 Overview.....	21
2.2 Unpacking the System.....	21
2.3 Preparing for Setup.....	21
Choosing a Setup Location.....	21
Rack Precautions.....	22
Server Precautions.....	22
Rack Mounting Considerations.....	22
Ambient Operating Temperature.....	22
Airflow.....	23
Mechanical Loading.....	23
Circuit Overloading.....	23
Reliable Ground.....	23
2.4 Installing the System into a Rack.....	24
Separating the Sections of the Rack Rails.....	24
Releasing the Inner Rail.....	25
Installing the Inner Rails on the Server.....	26
Installing the Outer Rails on the Rack.....	27
Installing the Server into the Rack.....	28
Removing the Server From the Rack.....	29
Removing the Outer Rails from the Rack.....	30

2.5 Installing the Cable Management Arm .....	31
<b>Chapter 3 Maintenance and Component Installation</b>	
3.1 Removing Power .....	34
3.2 Accessing the System.....	35
Removing the Top Cover.....	35
Removing the Mid-chassis Cover.....	35
Rear Cover.....	36
Removing the Rear Cover.....	36
3.3 Processor and Heatsink Installation.....	37
3.4 Memory Support and Installation .....	45
Memory Support.....	45
DIMM Module Population Sequence .....	46
DIMM Installation .....	47
DIMM Removal .....	47
3.5 Motherboard Battery.....	48
3.6 Storage Drives.....	49
Installing Drives.....	49
Removing Drive Carriers from the Server.....	50
Installing Rear Storage Drives.....	54
3.7 System Cooling .....	58
Installing a Air Shroud.....	60
3.8 Power Supply .....	62
3.9 PCI Expansion Cards .....	63
Installing an AIOM Card.....	66
Installing Internal Drives.....	67
3.10 Cable Routing Diagram.....	68
H13 Cable Plan - 2U 24 Simply Double (Default Configuration).....	68
H13 Cable Plan - 2U 24 Simply Double (Support 2x NVMe).....	69
H13 Cable Plan - 2U 24 Simply Double (Support 4x NVMe).....	70
Cables.....	71
<b>Chapter 4 Motherboard Connections</b>	
4.1 Power Connections .....	72
4.2 Headers.....	75
4.3 Rear I/O Ports .....	76
4.4 Front Control Panel.....	77

4.5 Front Control Panel.....	78
4.6 Jumpers.....	80
4.7 LED Indicators.....	81
<b>Chapter 5 Software</b>	
5.1 Microsoft Windows OS Installation.....	83
5.2 Driver Installation.....	85
5.3 SuperDoctor® 5.....	86
5.4 BMC.....	87
BMC ADMIN User Password .....	87
<b>Chapter 6 Optional Components</b>	
6.1 Additional Storage Drives.....	88
6.2 Storage Control Card and Cable(s) .....	88
6.3 TPM Security Module.....	89
6.4 Intel Virtual RAID on CPU (VROC).....	90
Requirements and Restrictions .....	90
Supported SSDs and Operating Systems .....	90
Additional Information .....	91
Hardware Key .....	91
Configuring NVMe RAID Manually.....	92
Status Indications.....	97
Hot Swap Drives .....	97
Hot-unplug .....	97
Hot-plug .....	97
Related Information Links .....	97
<b>Chapter 7 Troubleshooting and Support</b>	
7.1 Information Resources .....	98
Website .....	98
Direct Links for the ASG -2015S-E1CR24H/ASG -2015S-E1CR24L System.....	98
Direct Links for General Support and Information .....	98
7.2 Baseboard Management Controller (BMC).....	99
7.3 Troubleshooting Procedures .....	100
General Technique .....	100
No Power to the System.....	100
No Video .....	101
System Boot Failure .....	101

---

---

Memory Errors .....	101
Losing the System Setup Configuration .....	102
When the System Becomes Unstable .....	102
7.4 Crash Dump Using BMC.....	104
7.5 CMOS Clear .....	105
7.6 BMC Reset.....	105
7.7 Where to Get Replacement Components .....	106
7.8 Reporting an Issue .....	106
Technical Support Procedures .....	106
Returning Merchandise for Service.....	106
Vendor Support Filing System .....	107
7.9 Feedback.....	107
<b><i>Appendix A Standardized Warning Statements for AC Systems</i></b>	
<b><i>Appendix B System Specifications</i></b>	

## Contacting Supermicro

### Headquarters

Address: Super Micro Computer, Inc.  
980 Rock Ave.  
San Jose, CA 95131 U.S.A.

Tel: +1 (408) 503-8000

Fax: +1 (408) 503-8008

Email: [marketing@supermicro.com](mailto:marketing@supermicro.com) (General Information)  
[Sales-USA@supermicro.com](mailto:Sales-USA@supermicro.com) (Sales Inquiries)  
[Government\\_Sales-USA@supermicro.com](mailto:Government_Sales-USA@supermicro.com) (Gov. Sales Inquiries)  
[support@supermicro.com](mailto:support@supermicro.com) (Technical Support)  
[RMA@supermicro.com](mailto:RMA@supermicro.com) (RMA Support)  
[Webmaster@supermicro.com](mailto:Webmaster@supermicro.com) (Webmaster)

Website: [www.supermicro.com](http://www.supermicro.com)

### Europe

Address: Super Micro Computer B.V.  
Het Sterrenbeeld 28, 5215 ML  
's-Hertogenbosch, The Netherlands

Tel: +31 (0) 73-6400390

Fax: +31 (0) 73-6416525

Email: [Sales\\_Europe@supermicro.com](mailto:Sales_Europe@supermicro.com) (Sales Inquiries)  
[Support\\_Europe@supermicro.com](mailto:Support_Europe@supermicro.com) (Technical Support)  
[RMA\\_Europe@supermicro.com](mailto:RMA_Europe@supermicro.com) (RMA Support)

Website: [www.supermicro.nl](http://www.supermicro.nl)

### Asia-Pacific

Address: Super Micro Computer, Inc.  
3F, No. 150, Jian 1st Rd.  
Zhonghe Dist., New Taipei City 235  
Taiwan (R.O.C)

Tel: +886-(2) 8226-3990

Fax: +886-(2) 8226-3992

Email: [Sales-Asia@supermicro.com.tw](mailto:Sales-Asia@supermicro.com.tw) (Sales Inquiries)  
[Support@supermicro.com.tw](mailto:Support@supermicro.com.tw) (Technical Support)  
[RMA@supermicro.com.tw](mailto:RMA@supermicro.com.tw) (RMA Support)

Website: [www.supermicro.com.tw](http://www.supermicro.com.tw)

# Chapter 1

## Introduction

### 1.1 Overview

This chapter provides a brief outline of the functions and features of the ASG -2015S-E1CR24H/ASG -2015S-E1CR24L. Both systems are based on the H13SSW motherboard and the CSE-826S3TS-R1K62P1 chassis. The following provides an overview of the specifications and capabilities of the ASG -2015S-E1CR24H/ASG -2015S-E1CR24L.

System Overview	
<b>Motherboard</b>	H13SSW
<b>Chassis</b>	CSE-826S3TS-R1K62P1
<b>Processors</b>	Single AMD EPYC™ 9004 Series processor in SP5 socket up to 96 cores
<b>Memory</b>	12 DIMM slots for up to 3 TB of DDR5 ECC RDIMM/LRDIMM with speeds up to 4800 MT/s
<b>Storage</b>	24 hot-swap 3.5" SAS3/SATA3 drive bays Two rear hot-swap 2.5" SATA3 drive bays Two onboard M.2 NVMe slots PCIe 3.0 (22 x 110 mm) (Optional) Four rear hot-swap 2.5" NVMe U.2 drive bays
<b>Expansion Slots</b>	Four PCIe 5.0 x16 slots Two PCIe 5.0 x 8 slots Two PCIe 5.0 x 16 AIOM slots (See <a href="#">Section 3.9</a> for details)
<b>I/O Ports</b>	One RJ45 dedicated IPMI LAN port Two rear USB 3.0 ports One rear VGA port One rear COM port
<b>System Cooling</b>	Four heavy duty 8-cm fans with optimal fan speed control
<b>Power</b>	Two redundant 1600 W power supplies, 96Plus Titanium level
<b>Form Factor</b>	2U; (WxHxD) 17.2 x 3.5 x 34 in. (437 x 89 x 864 mm)

A Quick Reference Guide can be found on the product page of the Supermicro website.

The following safety models associated with the ASG -2015S-E1CR24H/ASG -2015S-E1CR24L have been certified as compliant with UL or CSA: 826S-16, 826S-R16H13.

### Models

- ASG -2015S-E1CR24H includes the HW RAID support via Broadcom® S3908.
- ASG -2015S-E1CR24L includes the HBA controller support via Broadcom® S3808.

## 1.2 System Features

The following views of the system display the main features.

### Front View



Figure 1-1. Front View

System Features: Front	
Feature	Description
Control Panel	Front control panel with LEDs and buttons (see <a href="#">Control Panel</a> for details)

Logical Storage Drive Numbers	
Item	Description
0-11	12 (front) hot-swap 3.5" SAS3/SATA3 drive bays
12-23	12 (riser) hot-swap 3.5" SAS3/SATA3 drive bays

### Drive Carrier Indicators

Each drive carrier has two LED indicators: an activity indicator and a status indicator. For RAID configurations using a controller, the meaning of the status indicator is described in the table below. For OS RAID or non-RAID configurations, some LED indications are not supported, such as hot spare.

Drive Carrier LED Indicators			
	Color	Blinking Pattern	Behavior for Device
<b>Activity LED</b>	Blue	Solid On	Idle SAS/NVMe drive installed
	Blue	Blinking	I/O activity
	Off		Idle SATA drive installed
<b>Status LED</b>	Red	Solid On	Drive failure
	Red	Blinking at 1 Hz	Rebuilding drive
	Red	Blinking with two blinks and one stop at 1 Hz	Hot spare for drive
	Red	On for five seconds, then off	Power on for drive
	Red	Blinking at 4 Hz	Identifying drive
	Green	Solid on	Safe to remove NVMe drive
	Amber	Blinking at 1 Hz	Do not remove NVMe drive

## Control Panel

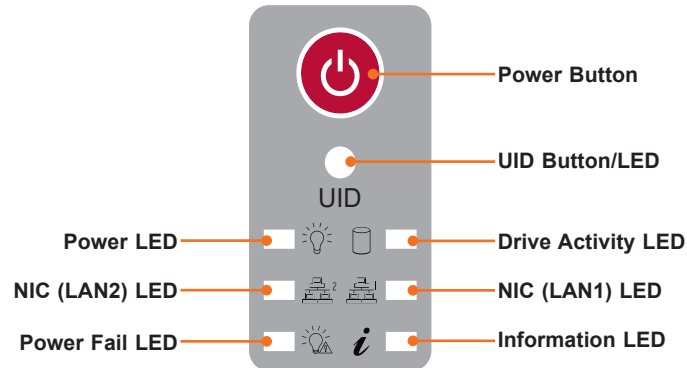


Figure 1-2. Control Panel

Control Panel Features	
Feature	Description
Power Button	The main power switch applies or removes primary power from the power supplies to the server but maintains standby power.
UID Button/LED	The unit identification (UID) button turns on or off the blue light function of the Information LED and a blue LED on the rear of the chassis.
Power LED	Indicates power is being supplied to the system power supply units. This LED is illuminated when the system is operating normally.
Drive Activity LED	Indicates activity on the storage drives when flashing.
NIC (LAN1) LED	Indicates network activity on LAN1 when flashing.
NIC (LAN2) LED	Indicates network activity on LAN2 when flashing.
Power Fail LED	Indicates a power supply module has failed.
Information LED	Alerts operator to several states, as noted in the table below.

Information LED	
Color, Status	Description
Red, solid	An overheat condition has occurred.
Red, blinking at 1 Hz	Fan failure, check for an inoperative fan.
Red, blinking at 0.25 Hz	Power failure, check for a non-operational power supply.
Red, solid, with Power LED blinking green	Fault detected
Blue and red, blinking at 10 Hz	Recovery mode
Blue, solid	UID has been activated locally to locate the server in a rack environment.
Blue, blinking at 1 Hz	UID has been activated using the BMC to locate the server in a rack environment.
Blue, blinking at 2 Hz	BMC is resetting
Blue, blinking at 4 Hz	BMC is setting factory defaults
Blue, blinking at 10 Hz with Power LED blinking green	BMC/BIOS firmware is updating

## Rear View

The ASG -2015S-E1CR24H/ASG -2015S-E1CR24L can be configured with PCIe slots or NVMe SSDs. The NVMe kit is not included in the standard system configuration. The system's rear will differ depending on the configuration, as shown below.

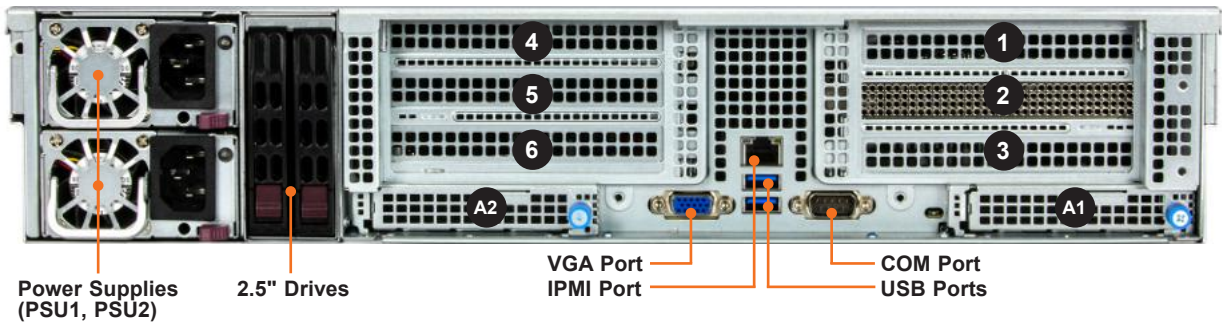


Figure 1-3. Rear View: Standard Configuration



Figure 1-4. Rear View: Configuration B



Figure 1-5. Rear View: Configuration C

**Note:** The right riser card bracket, MCP-240-00207-0N, is used in Configuration B. MCP-240-00206-0N is the left riser card bracket, and both MCP-240-00207-0N and MCP-240-00206-0N are used in Configuration C.

System Features: Rear	
Feature	Description
Power Supplies	Two redundant power supply modules (PSU1 on top, PSU2 below)
2.5" Drives	Two hot-swap 2.5" SATA3 storage drives
VGA Port	One video port
IPMI Port	One dedicated LAN port for IPMI
USB Ports	Two USB 3.0 ports
COM Port	One serial communication port

Expansion Slot Locations			
Slot	Configuration A	Configuration B	Configuration C
1	PCIe 5.0 x16	PCIe 5.0 x16	PCIe 5.0 x16*
2	PCIe 5.0 x8*	PCIe 5.0 x8*	PCIe 5.0 x16
3	PCIe 5.0 x16	PCIe 5.0 x16	N/A
4	PCIe 5.0 x8	PCIe 5.0 x16	N/A
5	PCIe 5.0 x16	N/A	N/A
6	PCIe 5.0 x16	N/A	N/A
A1	PCIe 5.0 x16 AIOM	PCIe 5.0 x16 AIOM	PCIe 5.0 x16 AIOM
A2	PCIe 5.0 x16 AIOM	PCIe 5.0 x16 AIOM	PCIe 5.0 x16 AIOM

Logical Storage Drive Numbers	
Item	Description
0_3	Optional four hot-swap 2.5" NVMe** drive bays (with riser kit)

\* Occupied by AOC-S3808L-L8IT-P/AOC-S3908L-H8IR-32DD-P SAS controller card.

\*\* NVMe support requires additional parts. See the [Optional Parts](#) list for more details.

### *Power Supply Indicator*

<b>Power Supply Indicator</b>	
<b>LED Color and State</b>	<b>Power Supply Condition</b>
Off	No AC power to modules
Amber, solid	AC cord unplugged and in redundant mode OR power supplies critical events causing a shutdown, failure, OCP, OVP, fan fail, OTP, UVP
Amber, blinking	Power supplies warning events where the power supplies continues to operate: high temperature, over voltage, under voltage, etc
Green, blinking	AC present, only 12 V standby ON (module off)
Green, solid	Output on, functioning normally

## 1.3 System Architecture

This section shows the locations of the system's main components.

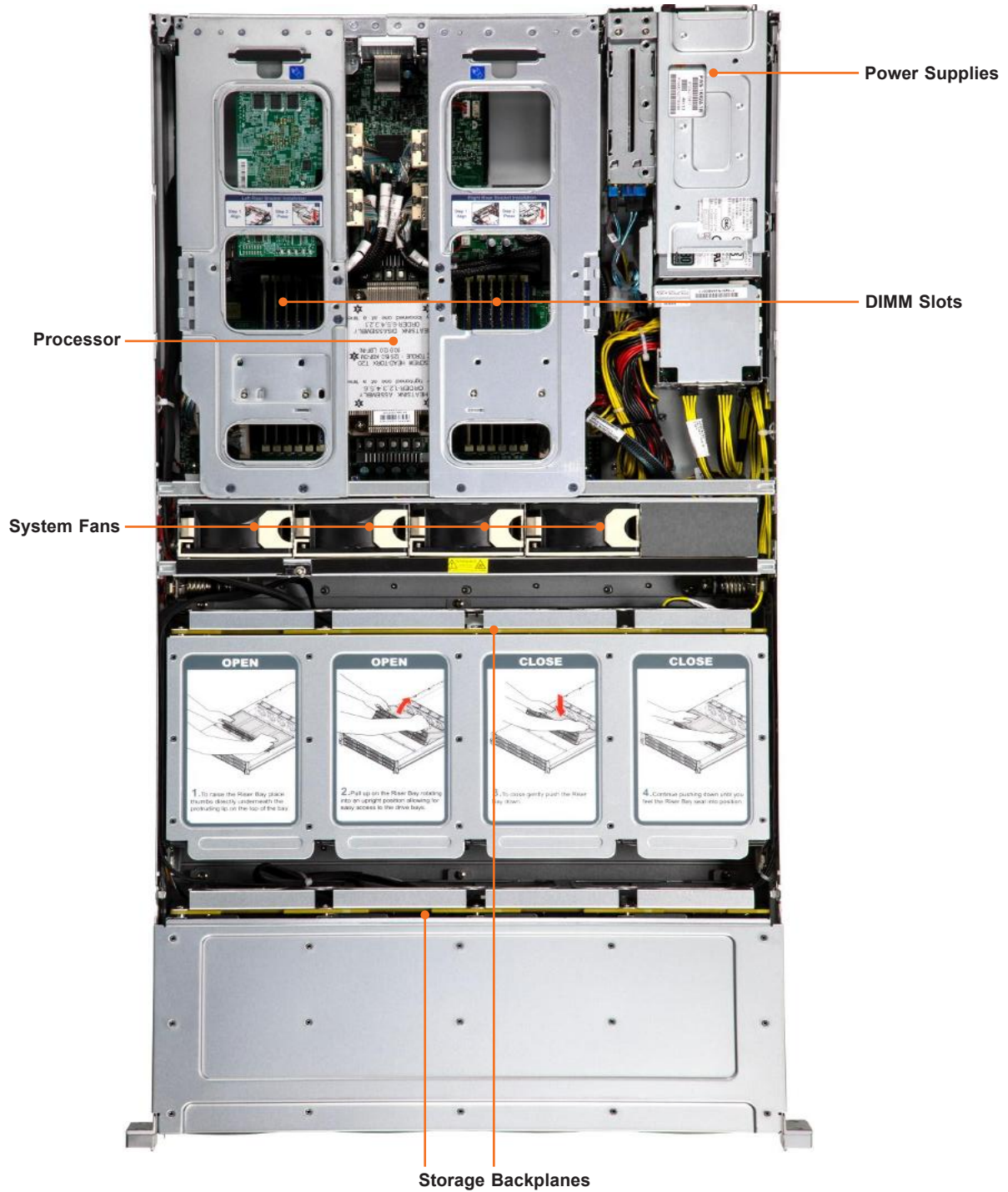


Figure 1-6. Main Component Locations

System Features: Top	
Feature	Description
Power Supplies	Dual redundant modules (PWS-1K62A-1R)
DIMM Slots	12 DDR5 DIMM slots
Processor	Single AMD EPYC™ 9004 Series processor with heatsinks (SNK-P0083P)
System Fans	Four 8-cm fans with optimal speed control (FAN-0168L4)
Storage Backplanes	Dual storage backplane (BPN-SAS3-826SA, BPN-SAS3-826SE1)

## 1.4 Motherboard Layout

Below is a layout of the H13SSW motherboard with the jumper, connector and LED locations shown. See the table on the following page for descriptions. For detailed descriptions, pinout information and jumper settings, refer to [Chapter 4](#) or the [Motherboard Manual](#).

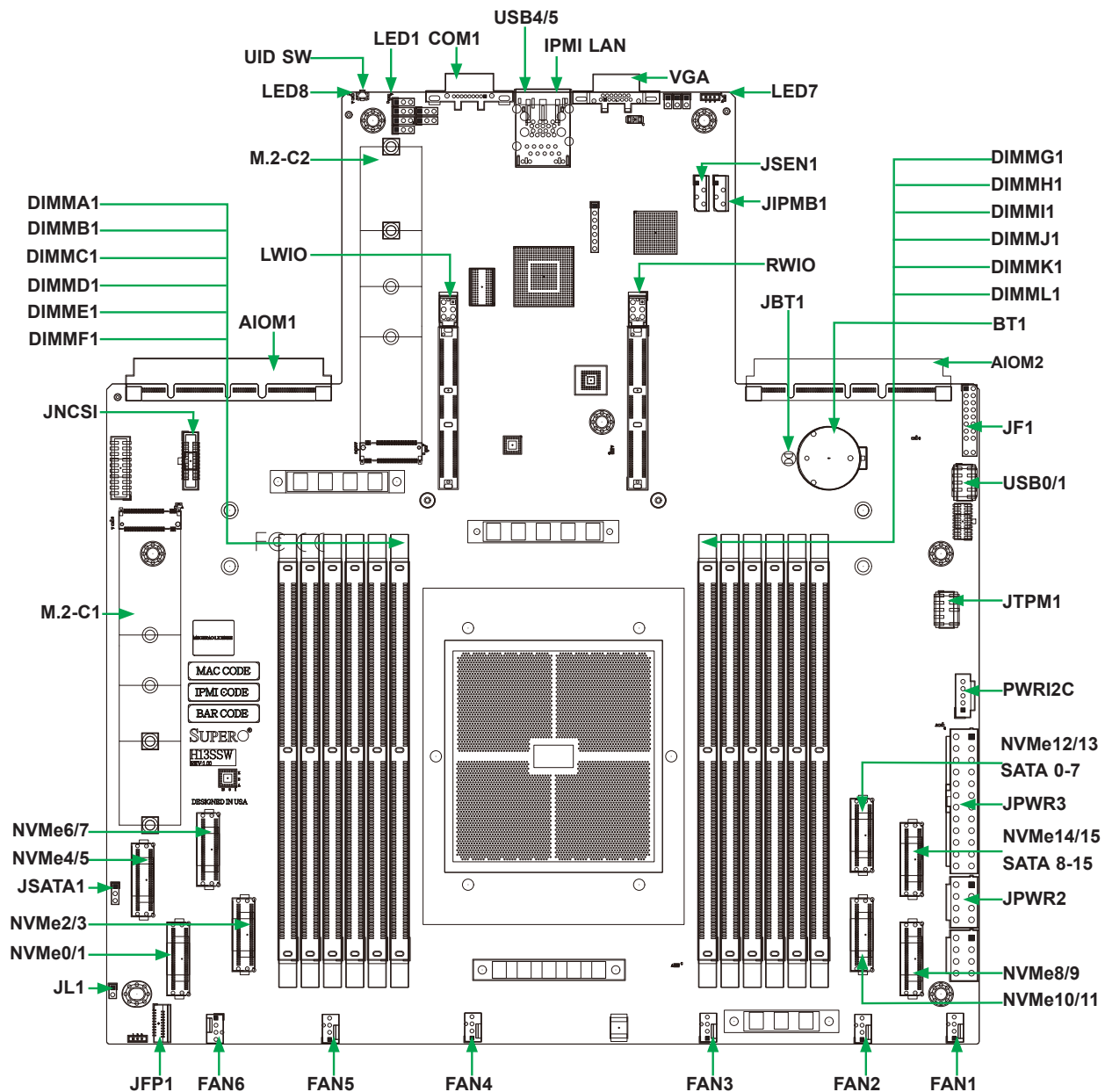


Figure 1-7. Motherboard Layout

### Notes:

- Use only the correct type of onboard CMOS battery as specified by the manufacturer. To avoid possible explosion, do not install the onboard battery upside down.
- "■" indicates the location of Pin 1.

## Quick Reference Table

Jumper	Description	Default Setting
JBT1	CMOS Clear	Open (Normal)
UID SW	Unit ID Switch (Push-Button Toggle Switch ON/OFF)	Off

LED	Description	Status
LED7	Power LED	Solid Green: Power On
LED1	BMC Heartbeat LED	Green: Blinking (BMC Normal) Green: Fast Blinking (BMC Initializing)
LED8	UID LED	Blue: UID Activated

Connector	Description
JL1	Chassis Intrusion Header
JSATA1	3-Pin Connector for Storage Use
JNCSI1	NCSI Connector
JPWR2	12V 8-Pin CPU Core Power Supply Connector
JPWR3	24-Pin ATX Power Supply Connector
JF1	Front Control Panel Header
BT1	Onboard Battery
M.2-C1/M.2-C2	M.2 PCIe Interfaces
NVMe0-11	NVMe Ports
NVMe12-15, SATA0-15	NVMe/SATA Hybrid Ports
JIPMB1	4-Pin BMC External I <sup>2</sup> C Header (For an IPMI-Supported Card)
DIMMA1-DIMML1	DIMM Slots
FAN1-FAN6	System Cooling Fans
AIOM1-AIOM2	Supermicro <sup>®</sup> Advanced I/O Module (AIOM) Slots
JFP1	Front Control Panel Header 1
LWIO/ RWIO	Riser Slots
IPMI LAN	RJ45 Dedicated IPMI LAN Port
JTPM1	TPM (Trusted Platform Module)/Port 80
PWRI2C	Power Supply SMBus I2C Header
COM1	Rear Panel COM Port #1
VGA	Rear Panel VGA Port
JSEN1	Inlet Sensor Header
USB0/1	USB 2.0 Ports
USB4/5	USB 3.0 Ports

**Note:** Jumpers, connectors, switches, and LED indicators that are not described in the preceding tables are for manufacturing testing purposes only, and are not covered in this manual.

## Motherboard Block Diagram

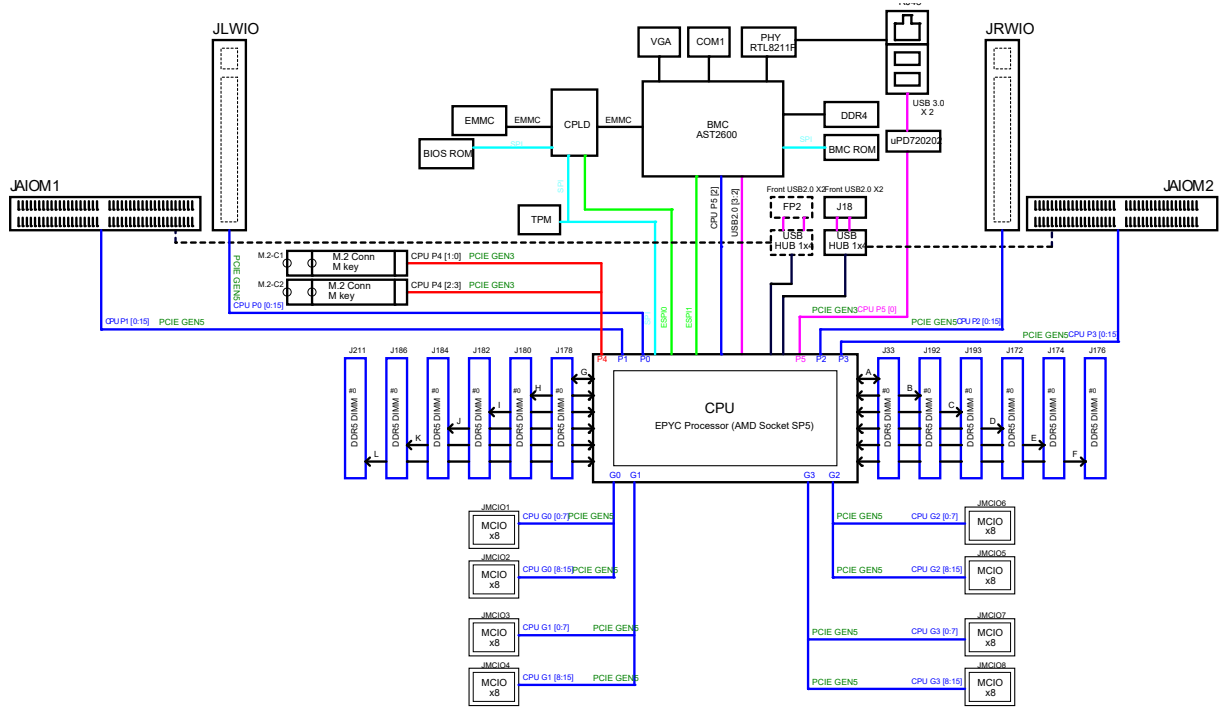


Figure 1-8. Motherboard Block Diagram

# Chapter 2

## Server Installation

### 2.1 Overview

This chapter provides advice and instructions for mounting your system in a server rack. If your system is not already fully integrated with processors, system memory etc., refer to [Chapter 3](#) for details on installing those specific components.

**Caution:** Electrostatic Discharge (ESD) can damage electronic components. To prevent such damage to PCBs (printed circuit boards), it is important to use a grounded wrist strap, handle all PCBs by their edges and keep them in anti-static bags when not in use.

### 2.2 Unpacking the System

Inspect the box in which the system was shipped, and note if it was damaged. If any equipment appears damaged, file a claim with the carrier.

Decide on a suitable location for the rack unit that will hold the server. It should be situated in a clean, dust-free area that is well ventilated. Avoid areas where heat, electrical noise and electromagnetic fields are generated. It will also require a grounded AC power outlet nearby. Be sure to read the precautions and considerations noted in [Appendix A](#).

### 2.3 Preparing for Setup

The box in which the system was shipped should include the rackmount hardware needed to install it into the rack. Please read this section in its entirety before you begin the installation.

#### Choosing a Setup Location

- The system should be situated in a clean, dust-free area that is well ventilated. Avoid areas where heat, electrical noise and electromagnetic fields are generated.
- Leave enough clearance in front of the rack so that you can open the front door completely (approximately 25 inches) and approximately 30 inches of clearance in the back of the rack to allow sufficient space for airflow and access when servicing.
- This product should be installed only in a Restricted Access Location (dedicated equipment rooms, service closets, etc.).

- This product is not suitable for use with visual display workplace devices according to §2 of the German Ordinance for Work with Visual Display Units.

## Rack Precautions

- Ensure that the leveling jacks on the bottom of the rack are extended to the floor so that the full weight of the rack rests on them.
- In single rack installations, stabilizers should be attached to the rack. In multiple rack installations, the racks should be coupled together.
- Always make sure the rack is stable before extending a server or other component from the rack.
- You should extend only one server or component at a time - extending two or more simultaneously may cause the rack to become unstable.
- Do not use a two-post "telco" type rack for 2U or larger servers.

## Server Precautions

- Review the electrical and general safety precautions in [Appendix A](#).
- Determine the placement of each component in the rack *before* you install the rails.
- Install the heaviest server components at the bottom of the rack first and then work your way up.
- Use a regulating uninterruptible power supply (UPS) to protect the server from power surges and voltage spikes and to keep your system operating in case of a power failure.
- Allow any drives and power supply modules to cool before touching them.
- When not servicing, always keep the front door of the rack and all covers/panels on the servers closed to maintain proper cooling.

## Rack Mounting Considerations

### *Ambient Operating Temperature*

If installed in a closed or multi-unit rack assembly, the ambient operating temperature of the rack environment may be greater than the room's ambient temperature. Therefore, consideration should be given to installing the equipment in an environment compatible with the manufacturer's maximum rated ambient temperature (TMRA).

### ***Airflow***

Equipment should be mounted into a rack so that the amount of airflow required for safe operation is not compromised.

### ***Mechanical Loading***

Equipment should be mounted into a rack so that a hazardous condition does not arise due to uneven mechanical loading.

### ***Circuit Overloading***

Consideration should be given to the connection of the equipment to the power supply circuitry and the effect that any possible overloading of circuits might have on overcurrent protection and power supply wiring. Appropriate consideration of equipment nameplate ratings should be used when addressing this concern.

### ***Reliable Ground***

A reliable ground must be maintained at all times. To ensure this, the rack itself should be grounded. Particular attention should be given to power supply connections other than the direct connections to the branch circuit (i.e. the use of power strips, etc.).



To prevent bodily injury when mounting or servicing this unit in a rack, you must take special precautions to ensure that the system remains stable. The following guidelines are provided to ensure your safety:

- This unit should be mounted at the bottom of the rack if it is the only unit in the rack.
- When mounting this unit in a partially filled rack, load the rack from the bottom to the top with the heaviest component at the bottom of the rack.
- If the rack is provided with stabilizing devices, install the stabilizers before mounting or servicing the unit in the rack.
- Slide rail mounted equipment is not to be used as a shelf or a work space.

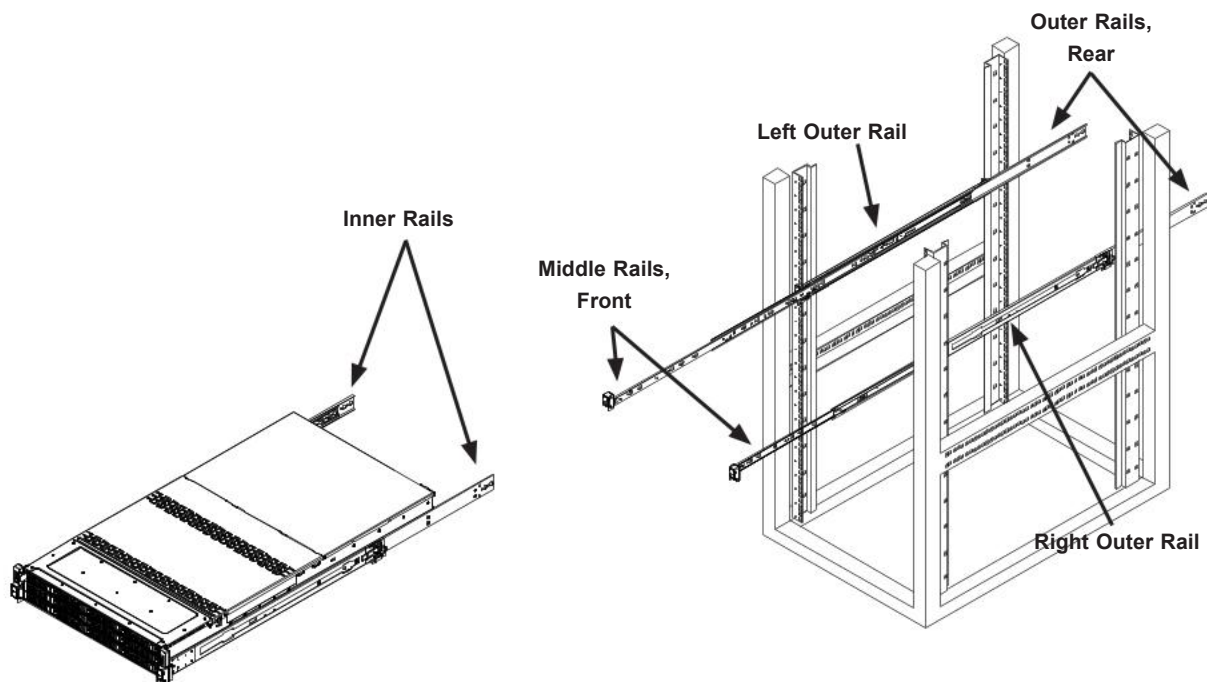
## 2.4 Installing the System into a Rack

This section provides information on installing the CSE-826S3TS-R1K62P1 chassis into a rack unit with the quick-release rails provided. There are a variety of rack units on the market, which may mean the assembly procedure will differ slightly. You should also refer to the installation instructions that came with the rack unit you are using.

**Note:** This rail will fit a rack between 26.5" and 36.4" deep.

### Separating the Sections of the Rack Rails

The chassis package includes two rail assemblies in the rack mounting kit. Each assembly consists of three sections: An inner rail that secures directly to the chassis, an outer rail that secures to the rack, and a middle rail that slides in the outer rail. These assemblies are specifically designed for the left and right side of the chassis.



**Figure 2-1. Identifying the Inner Rails, Middle Rails and Outer Rails**

**Note:** Figures are for illustrative purposes only. Your actual chassis may differ. Always install servers into racks from the bottom up.



Slide rail mounted equipment is not to be used as a shelf or a work space.



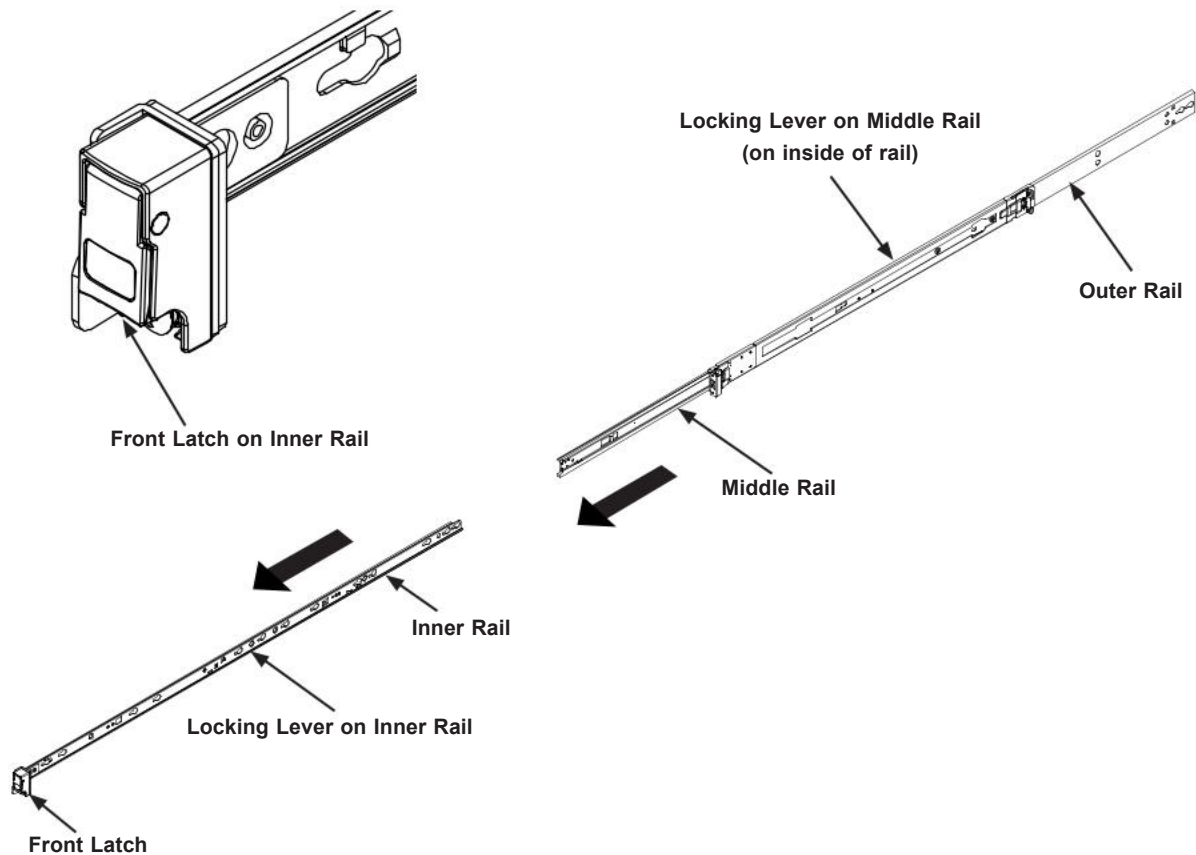
**Warning:** Do not pick up the server with the front handles. They are designed to pull the system from a rack only.

## Releasing the Inner Rail

It is necessary to release the inner rail from the middle and outer rails before installing the inner rail on the chassis.

### *Releasing the Inner Rail from the Middle and Outer Rails*

1. Lift the front latch on the inner rail and pull the inner rail out of the middle rail, and the middle rail out of the outer rail until the rails are fully extended.
2. Press down the locking lever on the inside of the inner rail to release the inner rail. Continue to pull the inner rail out of the middle rail.



**Figure 2-2. Extending the Rails and Releasing the Inner Rail**



**Warning:** Stability hazard. The rack stabilizing mechanism must be in place, or the rack must be bolted to the floor before you slide the unit out for servicing. Failure to stabilize the rack can cause the rack to tip over.

## Installing the Inner Rails on the Server

### *Installing the Inner Rails*

1. Confirm that the left and right inner rails have been correctly identified.
2. Place the inner rail firmly against the side of the chassis, aligning the pins on the side of the chassis with the slotted thru holes in the inner rail.
3. Slide the inner rail toward the rear of the chassis until the pins are at the end of the narrow slot, which secures the inner rail to the chassis. An optional screw may be added for extra security.
4. Repeat for the other inner rail.

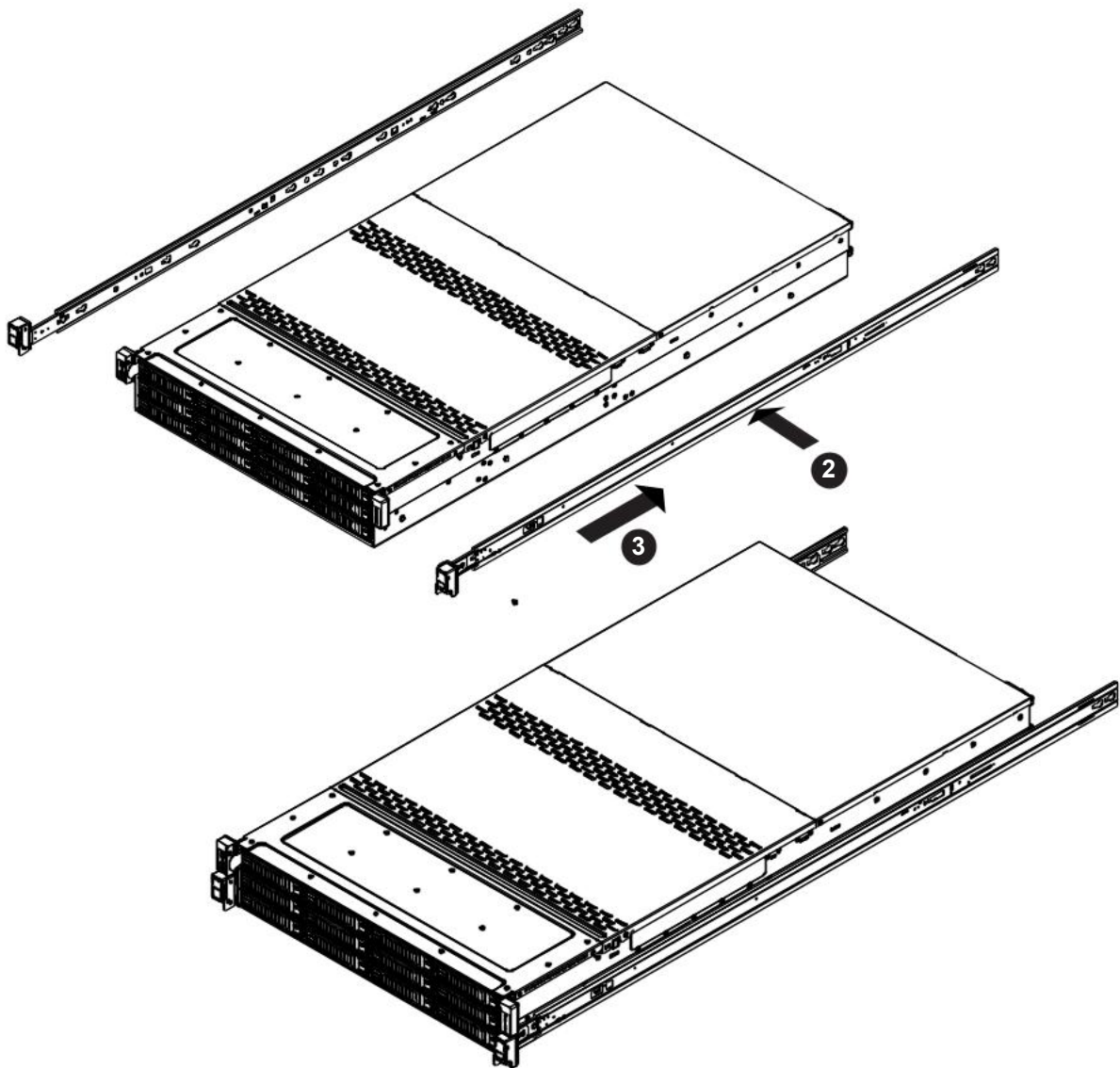
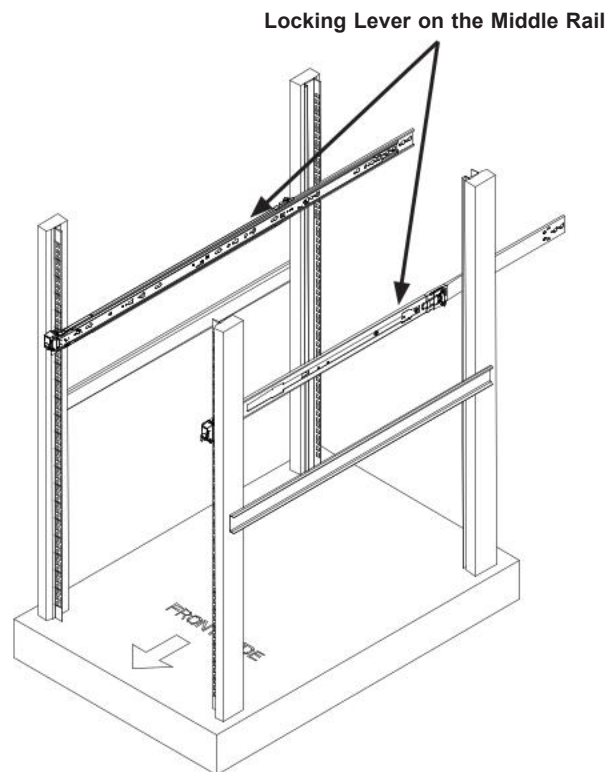


Figure 2-3. Installing the Inner Rails

## Installing the Outer Rails on the Rack

### *Installing the Outer Rails*

1. Confirm that the left and right outer rails have been correctly identified.
2. Release the small locking lever on the inside of the middle rail and push the middle rail back into the outer rail.
3. Insert the pins at the front of the outer rail into the square holes on the front of the rack. Push until the latch snaps into place.
4. The outer rail is actually two pieces that slide to lengthen. Pull out the rear of the outer rail, adjusting the length until the square pin assembly passes, then fits against the back of the rear post. Be careful to keep the rail level.
5. Insert the pins at the rear of the outer rail into the square holes on the rear of the rack. Push until the latch snaps into place.
6. Repeat for the other outer rail.



**Figure 2-4. Installing the Outer Rails**

**Note:** Figures are for illustrative purposes only. Your actual chassis may differ. Always install servers into racks from the bottom up.

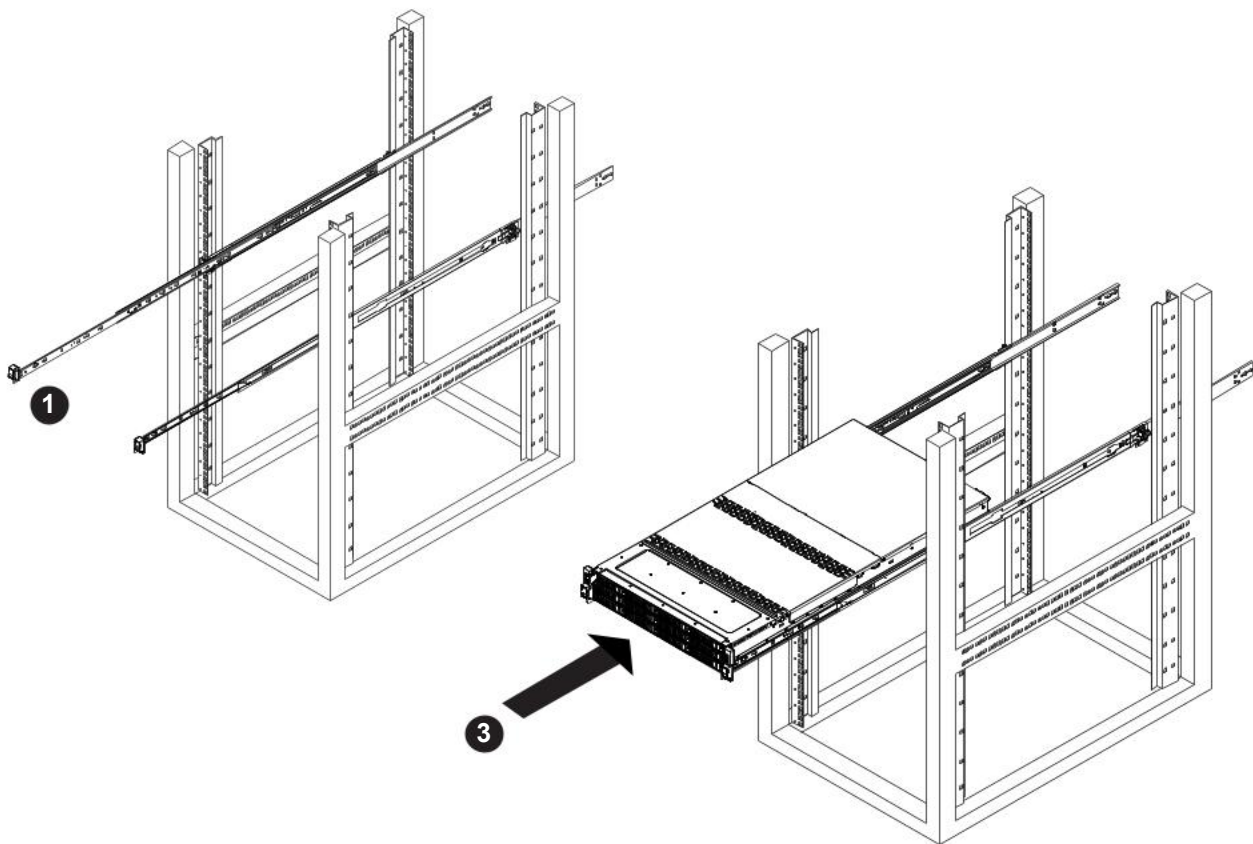
## Installing the Server into the Rack

After the rails are installed on the chassis and on the rack, the server can be installed in the rack. It is heavy and requires two to three people to lift.

### *Installing the Server into a Rack*

1. Pull both middle rails out the front of the outer rail until each clicks to a stop.
2. Align the inner rails on the chassis with the front of the middle rails.
3. Slide the inner rails on the chassis into the middle rails, keeping the pressure even on both sides. When partially in, the locking levers will stop further progress.
4. Press down the locking levers on the inside of the inner rails and push the chassis all the way into the rear of the rack. The front latches will click into place.

The chassis is now mounted in the rack. It can be pulled partially out for service by lifting both front latches.



**Figure 2-5. Installing the Server into the Rack**

**Note:** Figures are for illustrative purposes only. Your actual chassis may differ. Always install servers into racks from the bottom up.

## Removing the Server From the Rack

**Caution:** The server is heavy and requires two to three people to lift it out.

### *Removing the Server*

1. Lift the right and left front latches which are just below the LED control panels on the front edges of the chassis.
2. Pull the chassis forward until it clicks to a stop.
3. Press down the locking lever on the inside of the inner rail (Figure 2-2) to release the server. Continue to pull the server out of the middle rails.

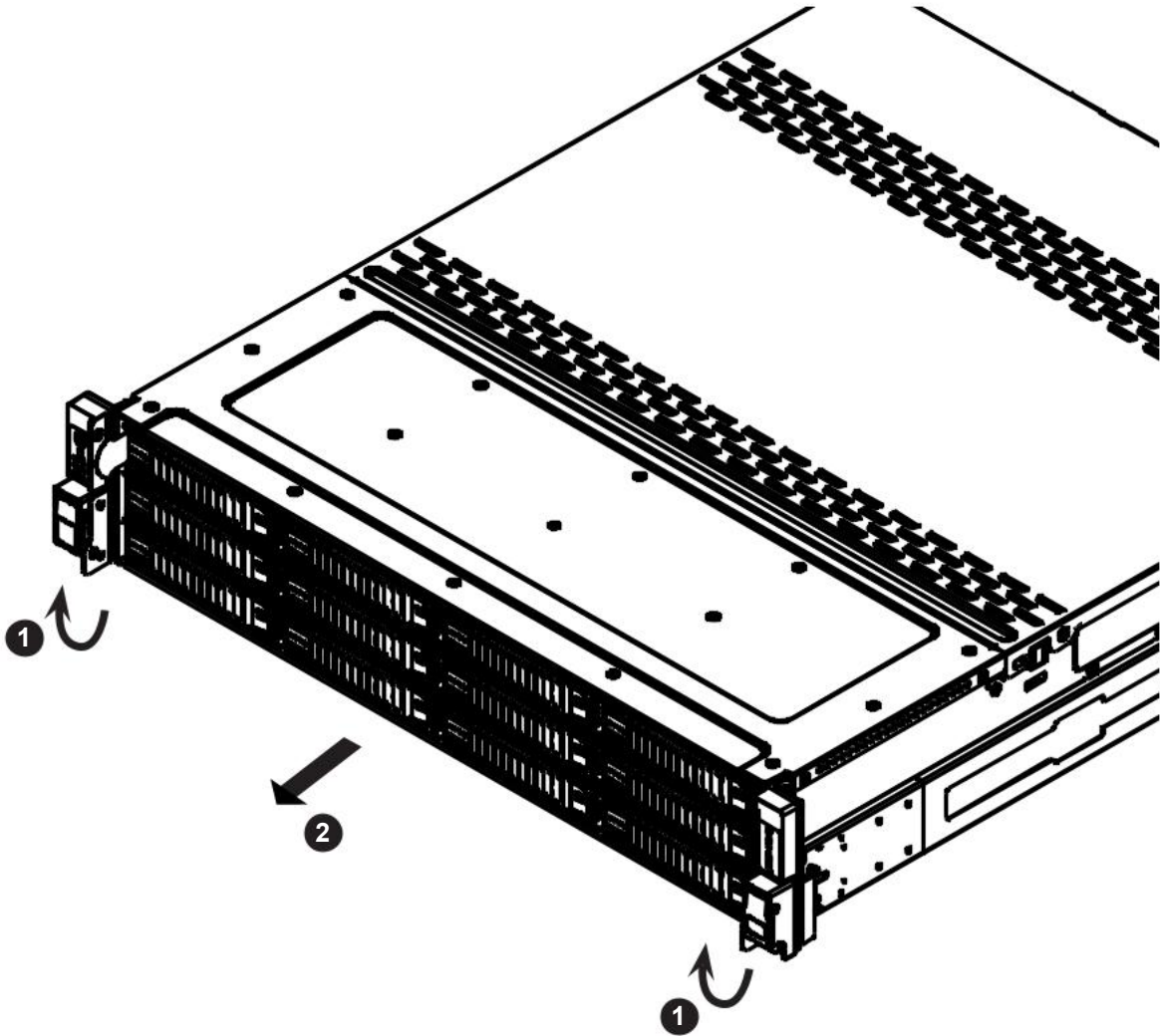


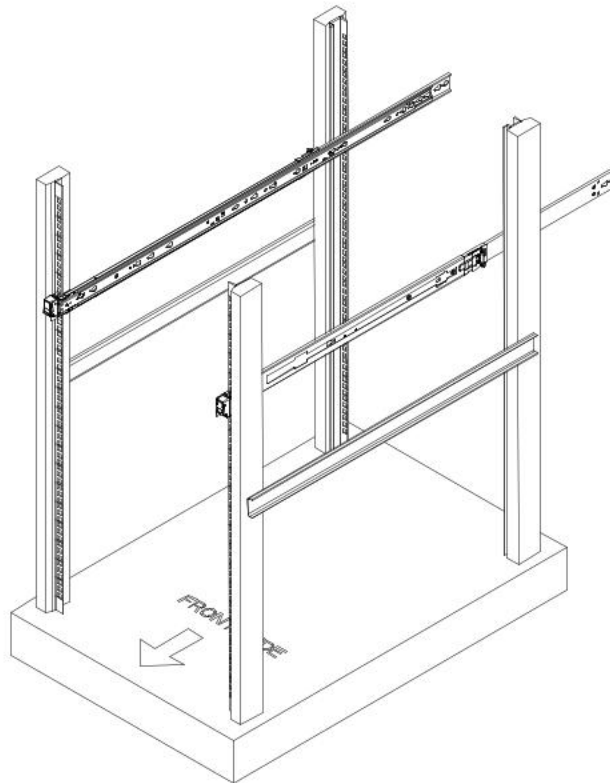
Figure 2-6. Removing the Server from the Rack

## Removing the Outer Rails from the Rack

In the uncommon event that it is necessary to remove the outer rails from the rack, follow these instructions. The chassis must be out of the rack.

### *Releasing the Outer Rails*

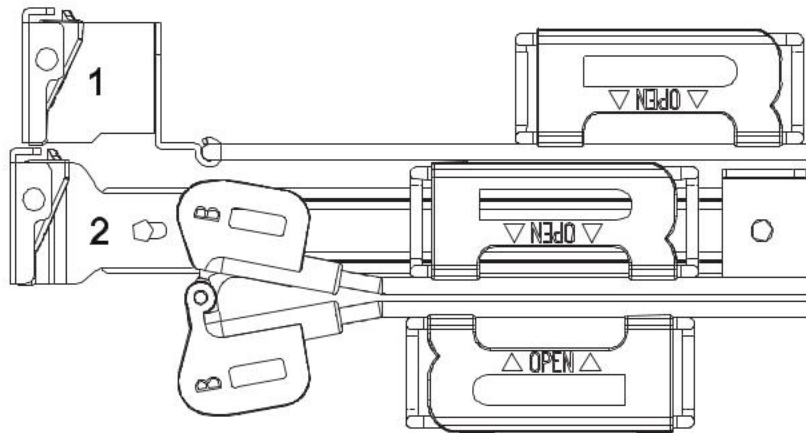
1. On the front of the outer rail, slide the small plastic safety slider (red in drawing) up and hold it while pushing the plastic release button (green in drawing) just below it.
2. While holding the release button in, pull the outer rail forward to disengage the pins and the front of the rail from the rack.
3. Support the front of the outer and middle rail assembly while releasing the rear.
4. Remove the outer rail from the rear of the rack in the same way as the front. Slide the safety slider up and push and hold the release button, then pull the rear pins out of the rack and remove the rail.



**Figure 2-7. Removing the Outer Rails**

## 2.5 Installing the Cable Management Arm

The SC826 chassis supports a cable management arm (CMA) that allows servicing while the server is running. The CMA keeps the rear cables organized and clear of the rail mechanisms when the system is extended out the front of the rack. The kit includes six fabric Velcro cable ties.

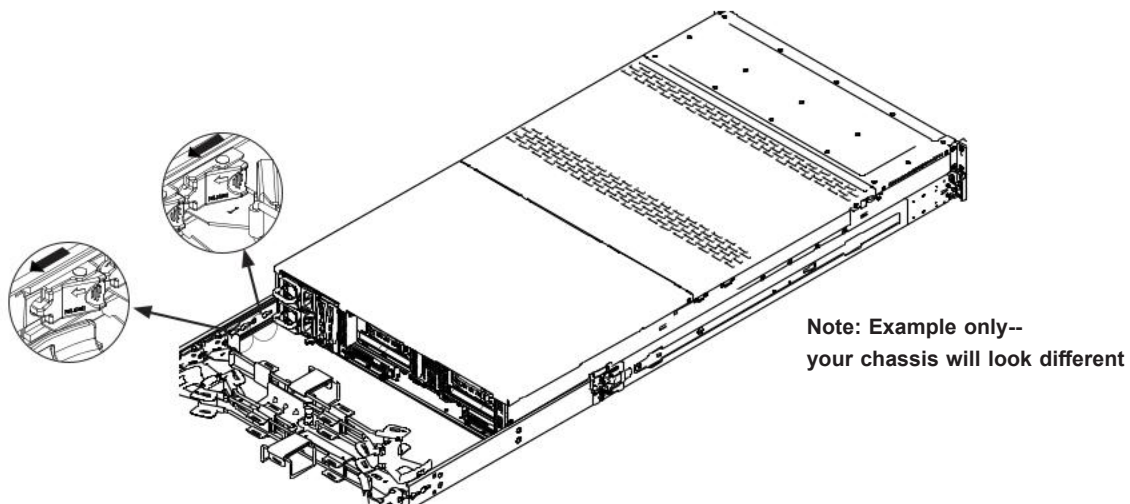


**Figure 2-8. Cable Management Arm and Velcro Straps**

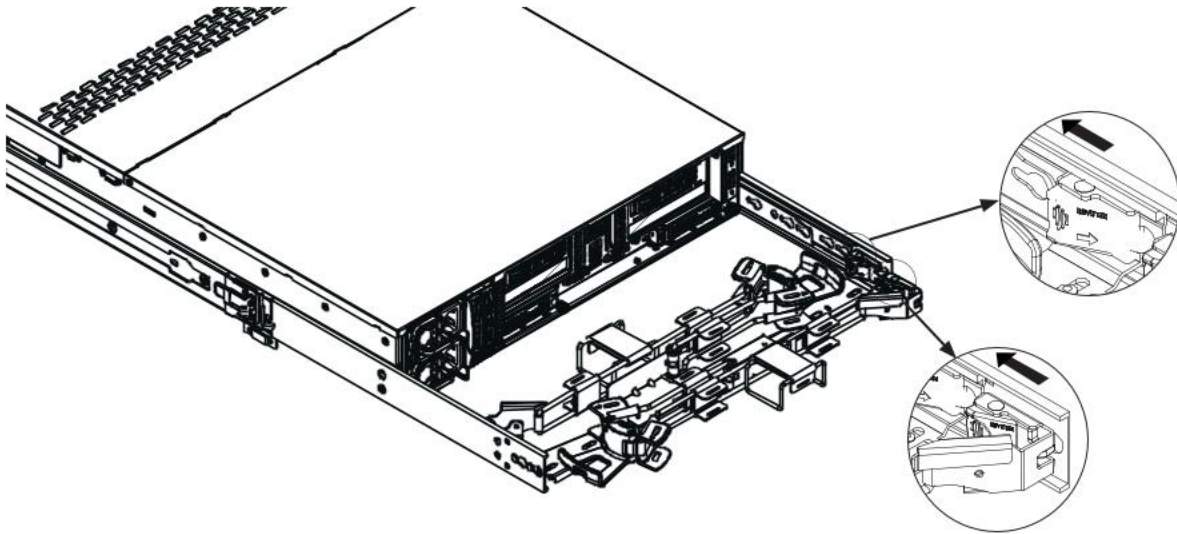
The CMA attaches to the rack mounting rails by means of four connectors. They are labeled on the connectors 1, 2, 3, and 4.

### ***Installing the Cable Management Arm***

1. Slide CMA connector #1 forward onto the two posts on the rear of the right inner rail (right side when viewed from the front). It snaps into place.
2. Slide CMA connector #2 forward onto the two posts on the rear of the right middle rail. It snaps into place.

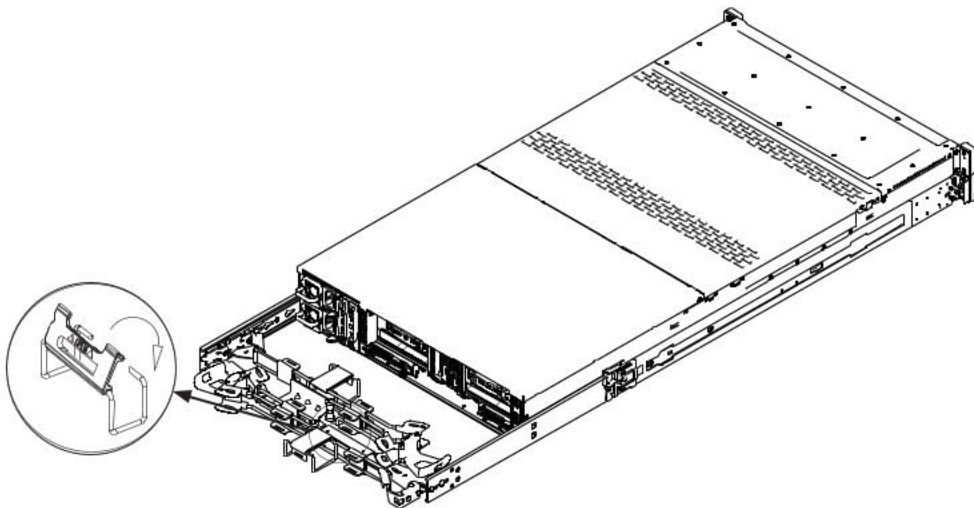


**Figure 2-9. Installing the Connectors 1 and 2**



**Figure 2-10. Installing the Connectors 3 and 4**

3. Slide CMA connector #3 forward onto the two posts on the rear of the left middle rail. It snaps into place.
4. For CMA connector #4, align the metal tabs with the slots on the rear of the left outer rail and push it forward. It snaps into place.



**Figure 2-11. Routing the Cables**

5. Open the six red plastic caps and route the cables into the wire carrier.
6. Use the six Velcro straps to secure the cables to the CMA. Use a strap on either side of each joint and one on each connector.
7. Slide the chassis forward and backward in the rack to confirm that the cable management arm is operating smoothly.

If at some time you must remove the cable management arm, follow the below procedure.

***Removing the Cable Management Arm***

1. Remove cables from the CMA, releasing the Velcro straps and the red plastic caps.
2. For CMA connector #4, pull the metal release tab toward the center of the rack and slide the connector toward the rear to release it.
3. For CMA connectors #3, #2, and #1, depress the front edge of the yellow plastic rocker lock, and slide the connector toward the rear to release it.

## Chapter 3

# Maintenance and Component Installation

This chapter provides instructions on installing and replacing main system components. To prevent compatibility issues, only use components that match the specifications and/or part numbers given.

Installation or replacement of most components require that power first be removed from the system. Please follow the procedures given in each section.

### 3.1 Removing Power

Use the following procedure to ensure that power has been removed from the system. This step is necessary when removing or installing non hot-swap components or when replacing a non-redundant power supply.

1. Use the operating system to power down the system.
2. After the system has completely shut-down, disconnect the AC power cord(s) from the power strip or outlet. (If your system has more than one power supply, remove the AC power cords from all power supply modules.)
3. Disconnect the power cord(s) from the power supply module(s).

**Note:** This caution statement applies when changing any component or subsystem that is not hot-swap/hot-plug.

## 3.2 Accessing the System

The chassis features a removable top cover for access to the internal components.

### *Removing the Top Cover*

#### **Mid-chassis Cover**

The mid-chassis cover can be removed to access the mid-chassis drives or fans while the server continues to operate.

### *Removing the Mid-chassis Cover*

Remove the two screws securing each side of the cover, push in the release buttons, then lift the cover.

**Warning:** Except for short periods of time, do not operate the server without the cover in place. The chassis cover must be in place to allow for proper airflow and to prevent overheating.

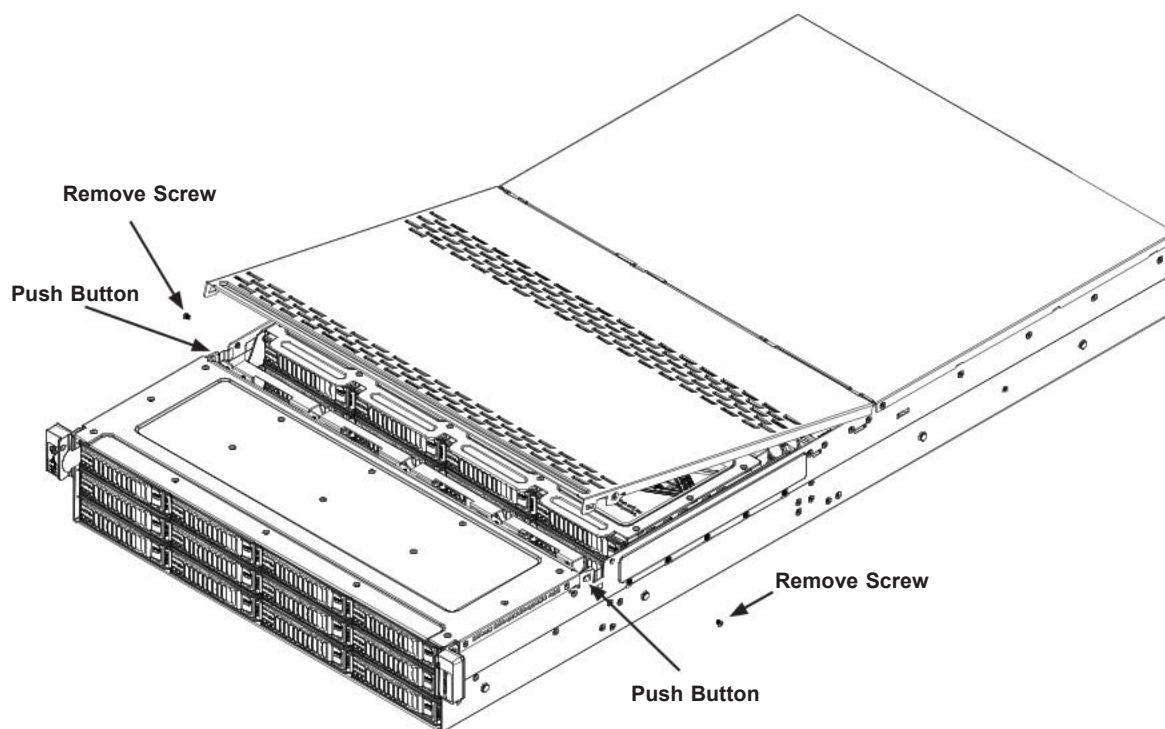


Figure 3-1. Removing the Chassis Cover

## Rear Cover

### *Removing the Rear Cover*

Remove the two screws on the side of the chassis and the thumbscrew at the rear of the chassis, then slide the cover to the rear and off.

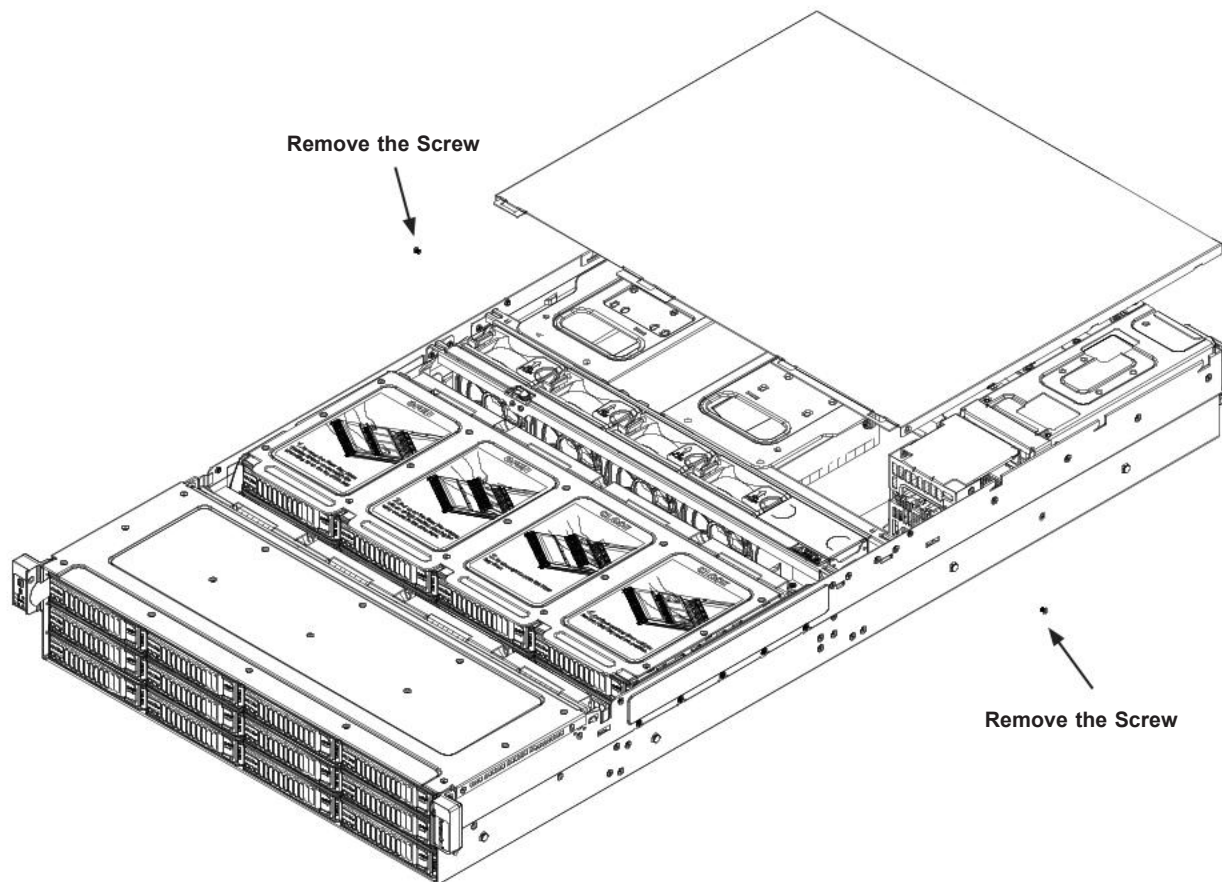


Figure 3-2. Removing the Rear Cover

## 3.3 Processor and Heatsink Installation

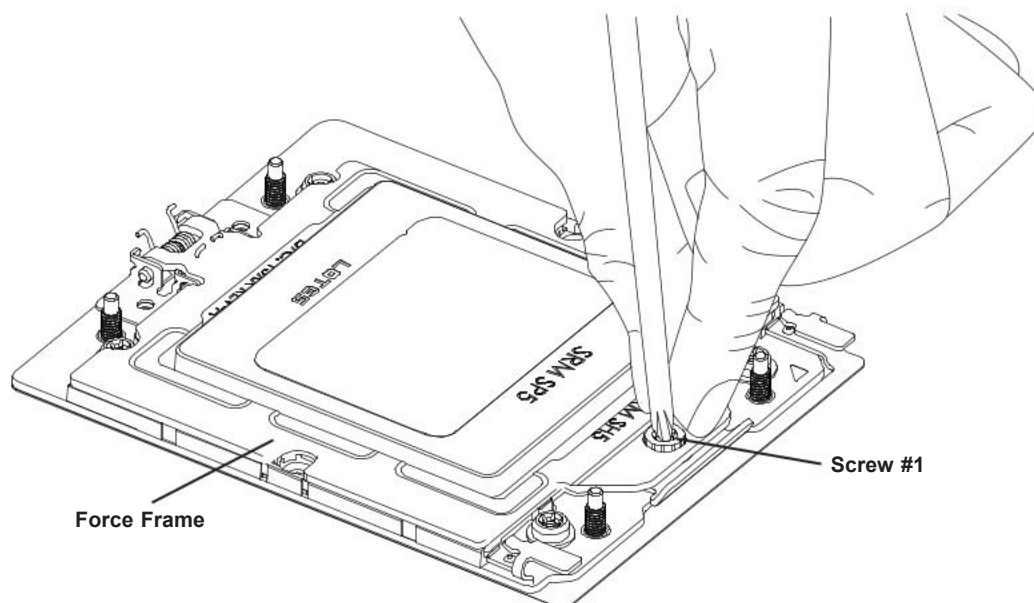
**Warning:** When handling the processor package, avoid placing direct pressure on the label area of the fan.

**Important:**

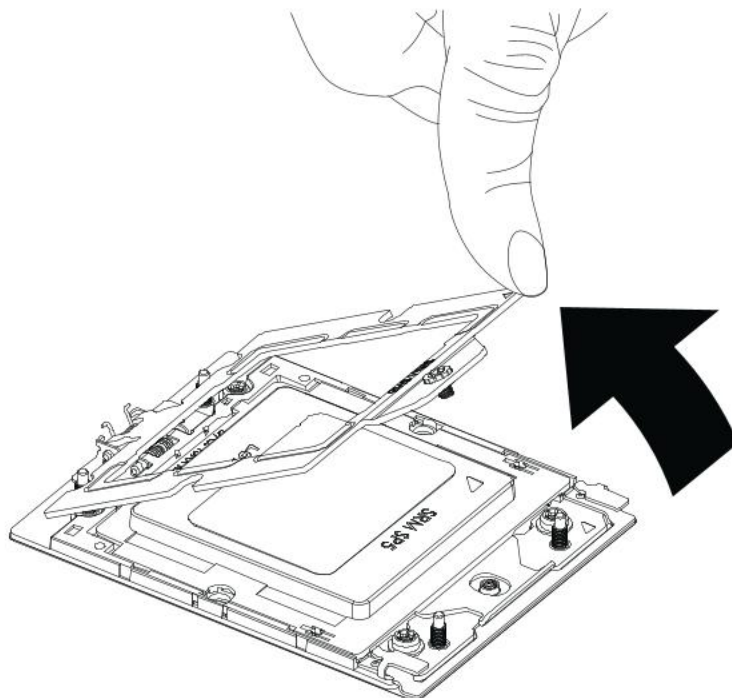
- For the Processor/Heatsink installation you need to use a T20 screwdriver when opening/closing the CPU socket.
- Always connect the power cord last, and always remove it before adding, removing or changing any hardware components. Make sure that you install the processor into the CPU socket before you install the CPU heatsink.
- If you buy a CPU separately, make sure that you use an AMD-certified multi-directional heatsink only.
- Make sure to install the motherboard into the chassis before you install the CPU heatsink.
- When receiving a motherboard without a processor pre-installed, make sure that the plastic CPU socket cap is in place and none of the socket pins are bent; otherwise, contact your retailer immediately.
- Refer to the Supermicro website for updates on CPU support.

### ***Installing the Processor and Heatsink***

1. Unscrew the screw #1 holding down the force frame.

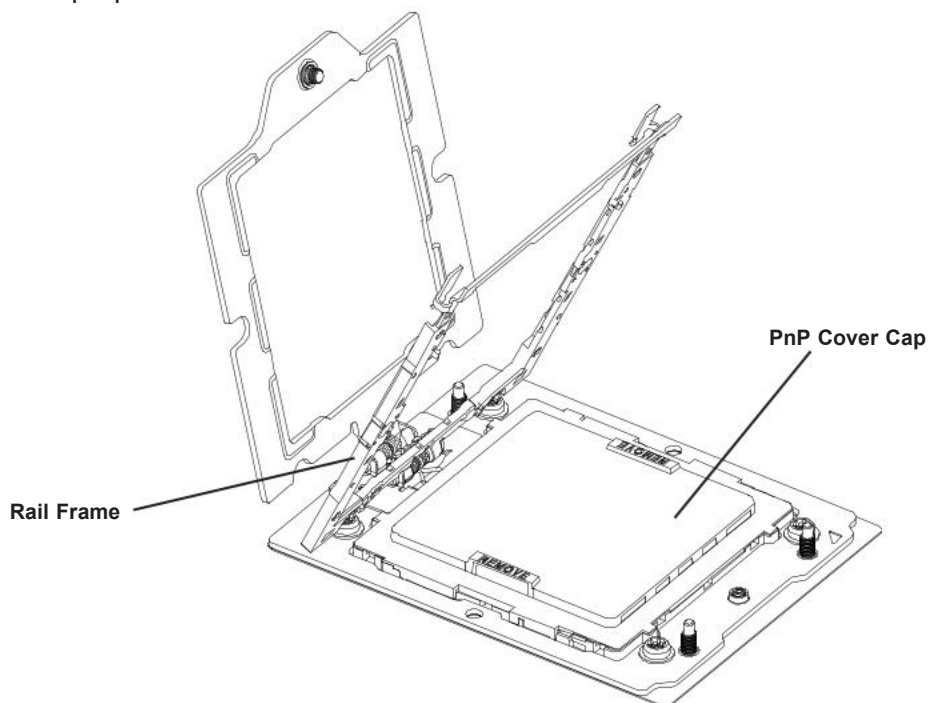


2. The spring-loaded force frame will raise up after the screw securing it (#1) is removed. Gently allow it to lift up to its stopping position.

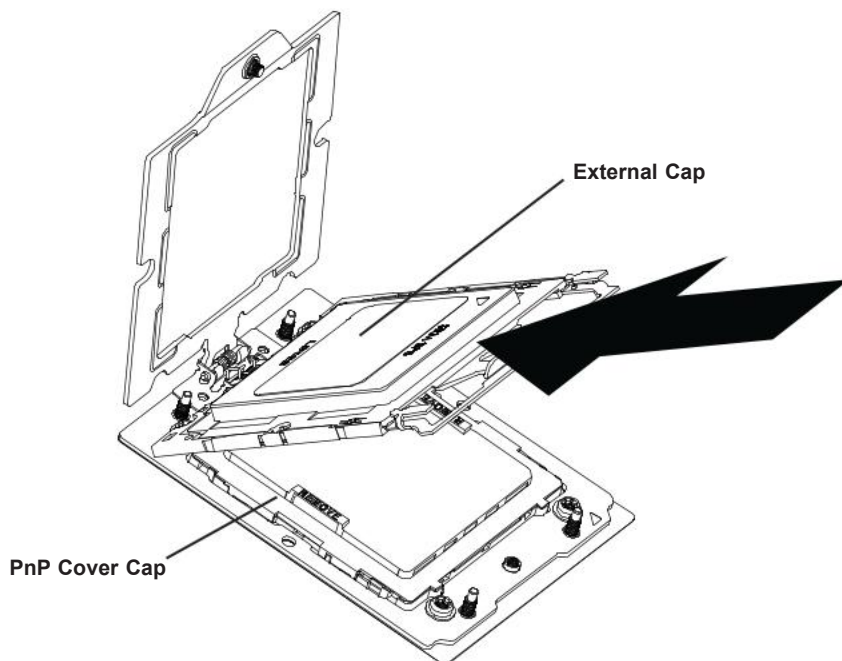


3. Lift the rail frame up by gripping the lift tabs near the front end of the rail frame. While keeping a secure grip of the rail frame, lift it to a position so you can do the next step of removing the external cap.

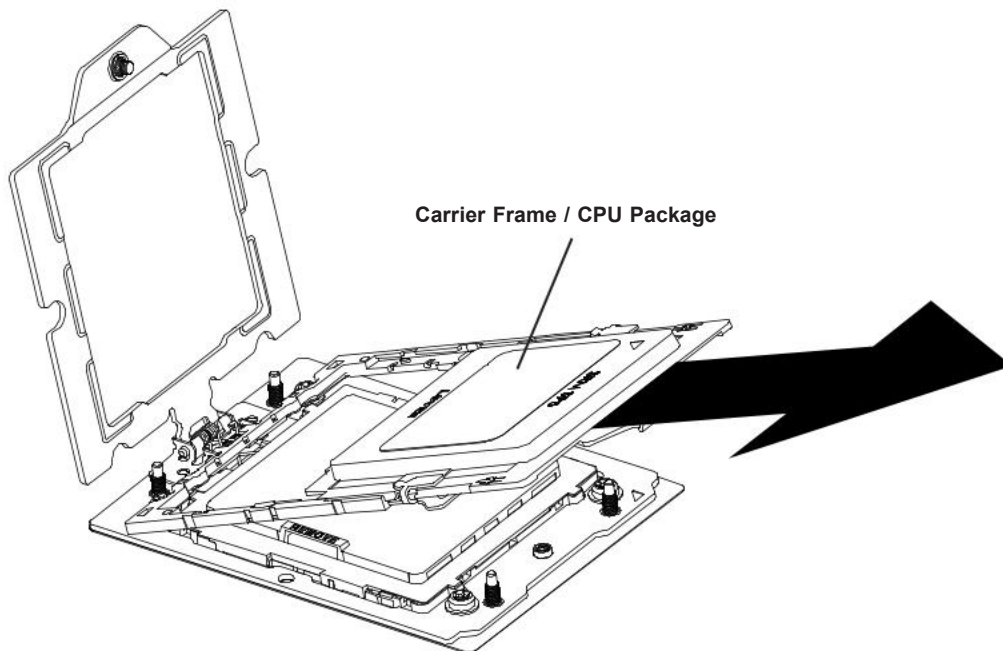
**Note:** The rail frame is spring loaded, so keep a secure grip on it as you lift it so it does not snap up.



4. Remove the external cap from the rail frame by pulling it upwards through the rail guides on the rail frame.

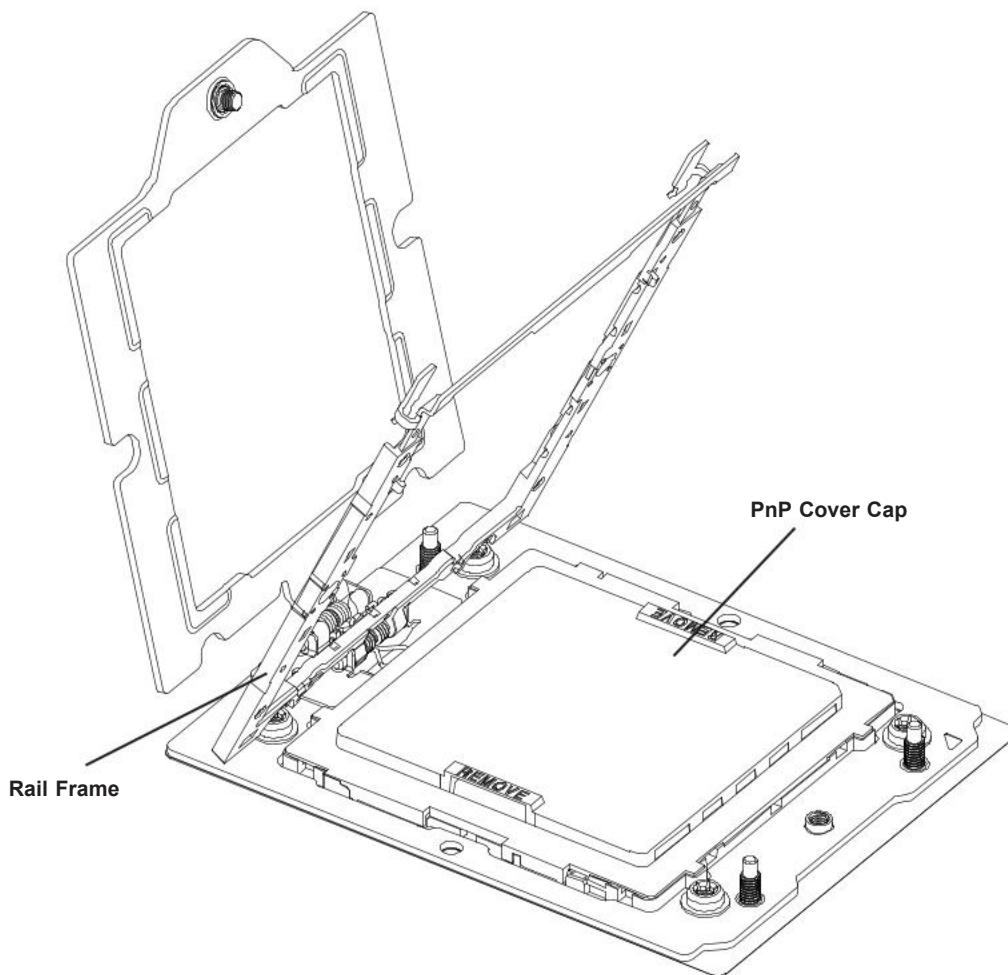


5. The CPU package is shipped from the factory with the carrier frame pre-assembled. Grip the handle of the carrier frame/CPU package assembly from its shipping tray, and while gripping the handle, align the flanges of the carrier frame onto the rails of the rail frame so its pins will be at the bottom when the rail frame is lowered later.
6. Slide the carrier frame/CPU package downwards to the bottom of the rail frame. Ensure the flanges are secure on the rails as you lower it downwards.



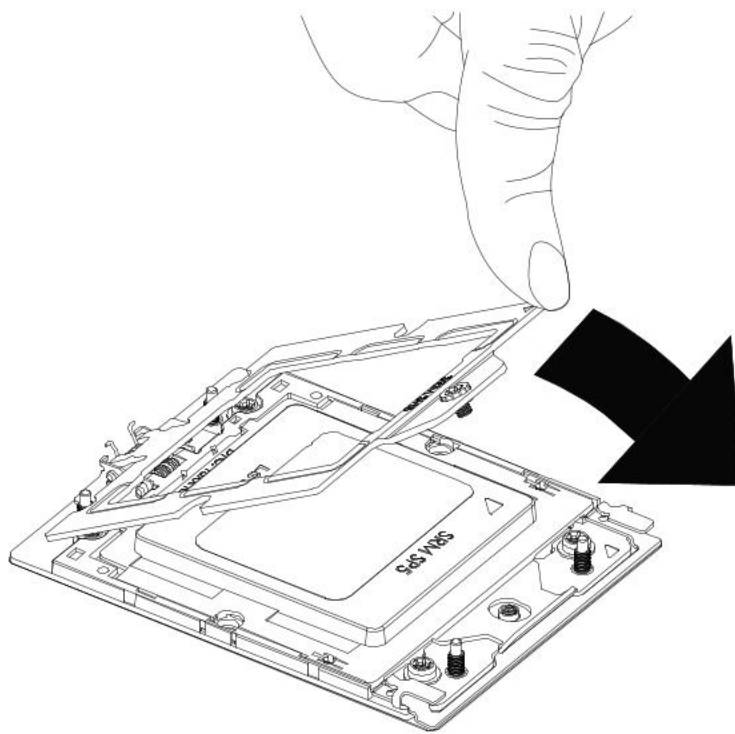
**Note:** You can only install the CPU inside the socket in one direction with the handle at the top. Make sure that it is properly inserted into the CPU socket before closing the rail frame plate. If it doesn't close properly, do not force it as it may damage your CPU. Instead, open the rail frame plate again, and double-check that the CPU is aligned properly.

7. Lift up the rail frame till it securely rests in upright position. Then remove the PnP cover cap from the CPU socket below. Grip the two lift tabs marked "Remove" at the middle of the cap and pull vertically upwards to remove the PnP cover cap.

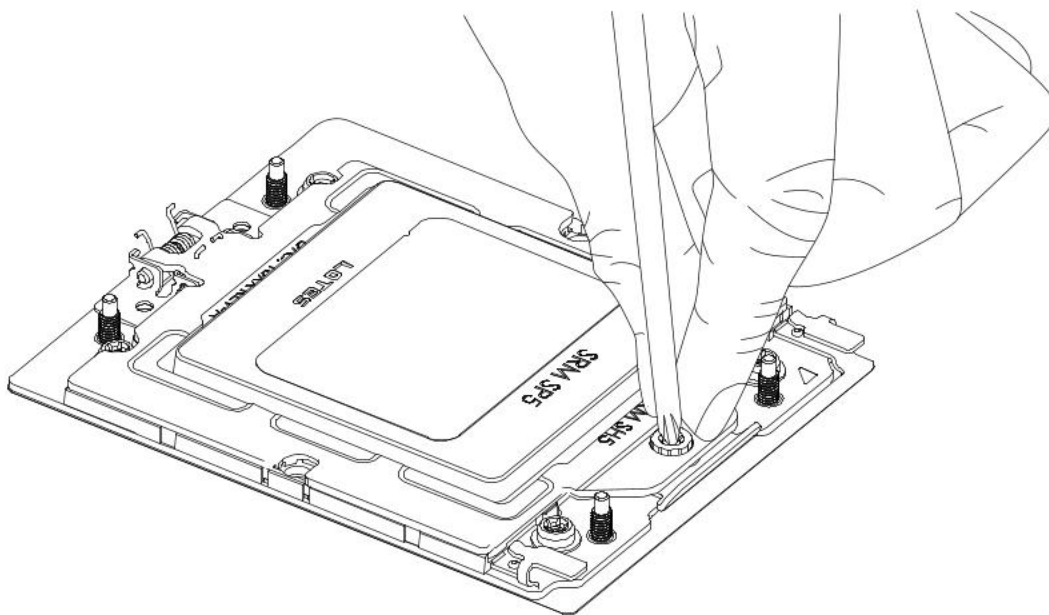


**Warning!** The exposed socket contacts are extremely vulnerable and can be damaged easily. Do not touch or drop objects onto the contacts and be careful removing the PnP cover cap and when placing the rail frame over the socket.

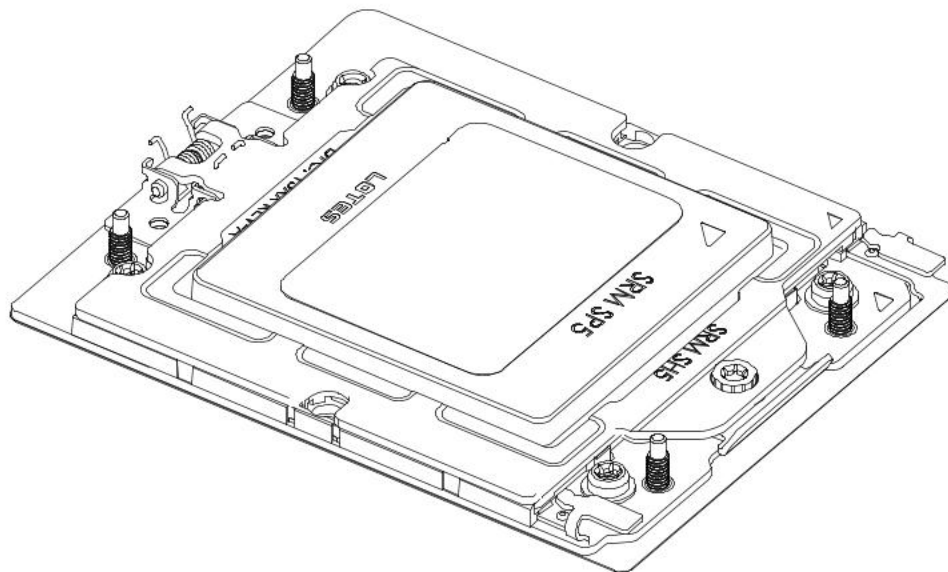
8. Gently lower the rail frame down onto the socket until the latches on the rail frame engage with the socket housing and it rests in place. **DO NOT** force it into place!



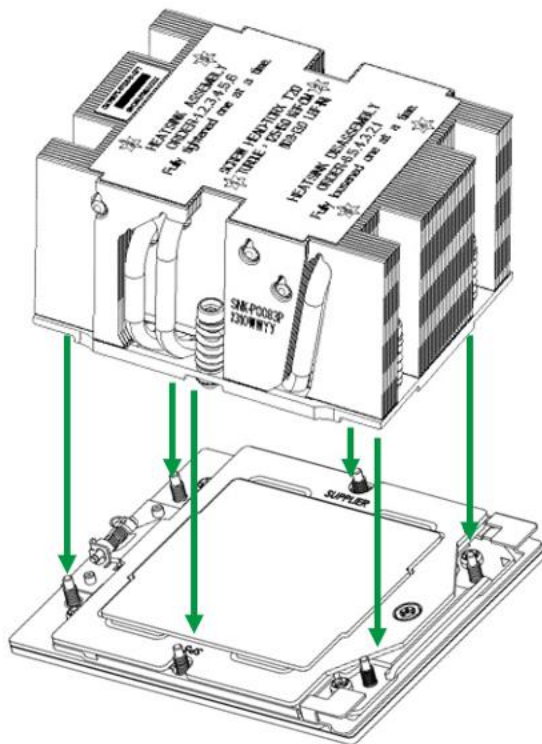
9. Note that the force frame is spring loaded and has to be held in place before it is secured. **Use a torque screwdriver, set it at 12.5-15.0 kgf-cm (10.85-13.01 lbf-in) with a Torx T20 screw head bit, to prevent damage to the CPU.**



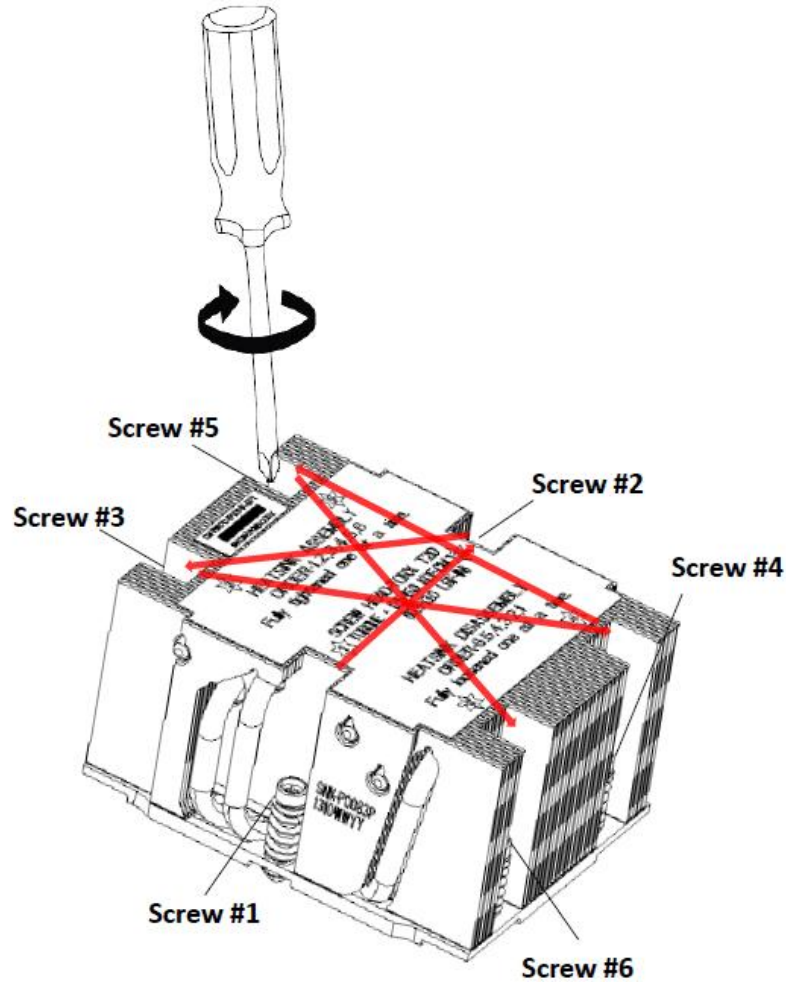
10. Replace and tighten the screws in the same order they were removed. When finished, the force frame will be secure over both the rail frame and CPU package.



11. After the force frame is secured and the CPU package is in place, now you must install the heatsink to the frame. Lower the heatsink down till it rests securely over the six screw holes on CPU package on the socket frame.



- Using a diagonal pattern, tighten the six screws down on the heatsink in a clockwise fashion until secure. The heatsink will now be secured and you have finished installing the processor and heatsink onto the motherboard. Repeat this procedure for any remaining CPU sockets on the motherboard.



### **Un-installing the Processor and Heatsink**

1. Remove the heatsink attached to the top of the CPU package by reversing the installation procedure.
2. Clean the thermal grease left by the heatsink on the CPU package lid to limit the risk of it contaminating the CPU package land pads or contacts in the socket housing.
3. Unscrewing the plate and lift the force frame to the vertical position.
4. Lift the rail frame using the lift tabs near the front end of the rail frame. Note that the rail frame is spring loaded, so be careful lifting it up into a vertical position.
5. Grip the handle of the carrier frame and pull upwards to extract it from the rail frame. Return the carrier frame/CPU package to its original shipping container.
6. Grip the handle on the external cap and return it to the rail frame sliding it downwards till it rests in the frame.
7. Gripping the rail frame, rotate it downwards till it rests above and locks over the socket housing in its horizontal position.
8. Push and rotate down the force frame till it is over the external cap and rail frame into a horizontal position.
9. While holding down the force frame, secure it back to the socket frame by securing screw #1 in place.

## 3.4 Memory Support and Installation

### Memory Support

The H13SSW supports up to 3 TB of ECC DDR5 4800 MT/s speed, RDIMM/LRDIMM/3DS memory in 12 slots. Refer to the table below for additional memory information.

**Note:** Check the Supermicro website for possible updates to memory support.

DIMM Population Guide												
Type	Channel											
	F1	E1	D1	C1	B1	A1	G1	H1	I1	J1	K1	L1
CPU1 & 1 DIMM						V						
CPU1 & 2 DIMM						V	V					
CPU1 & 4 DIMM*				V		V	V		V			
CPU1 & 6 DIMM				V	V	V	V	V	V			
CPU1 & 8 DIMM		V		V	V	V	V	V	V		V	
CPU1 & 10 DIMM		V	V	V	V	V	V	V	V	V	V	
CPU1 & 12 DIMM	V	V	V	V	V	V	V	V	V	V	V	V

Populating RDIMM/RDIMM 3DS DDR5 Memory Modules with AMD EPYC™ 9004 Series Processors				
Type	DIMM Population	Maximum DIMM Capacity		Maximum Frequency (MT/s)
	DIMM1	1 Channel	12 Channels	
RDIMM	1R (1 rank)	32 GB	384 GB	4800
	2R (2 ranks)	64 GB	768 GB	4800
3DS RDIMM	2S2R (4 ranks)	128 GB	1.5 TB	4800
	2S4R (8 ranks)	256 GB	3 TB	4800

## DIMM Module Population Sequence

Please see the previous page for the specific order or sequence required when installing memory modules. Keep the following in mind:

- Mixed DIMM speeds can be installed. However, all DIMMs will run at the speed of the slowest DIMM.
- The motherboard will support odd-numbered modules (1 or 3 modules installed). Populating with an even number of DIMMs will result in interleaved memory. However, to achieve the best memory performance, fully populate the motherboard with validated memory modules.

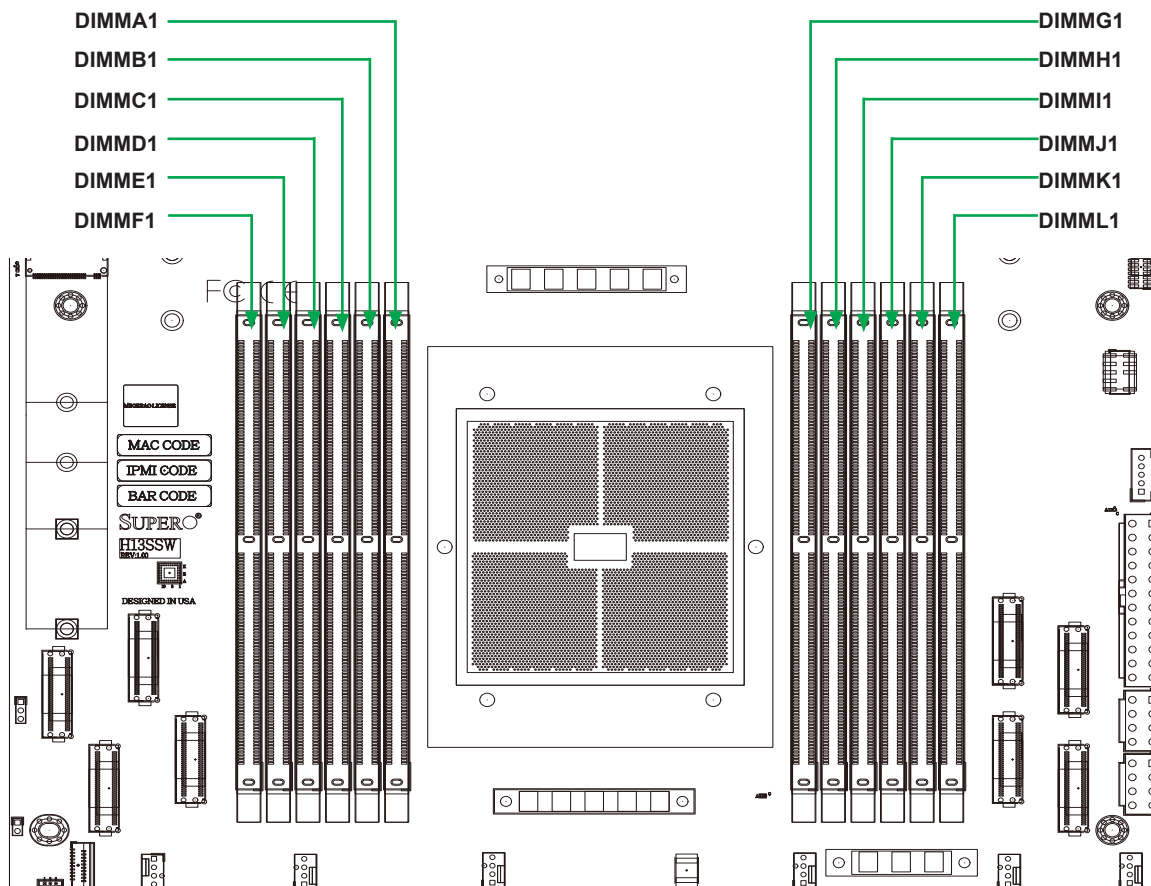
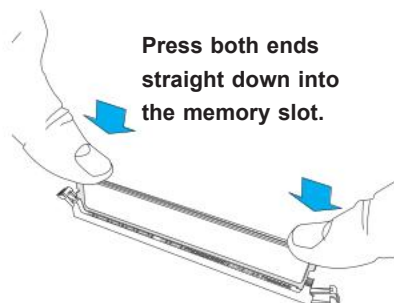
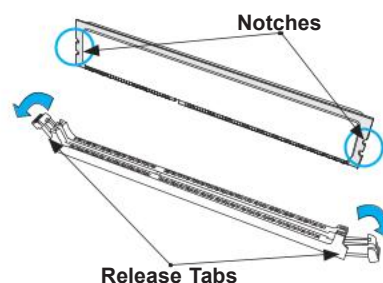
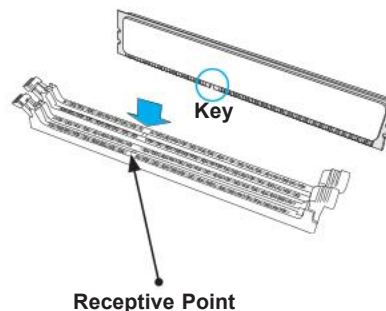


Figure 3-3. DIMM Numbering

## DIMM Installation

1. Insert the desired number of DIMMs into the memory slots. See [Memory Support](#) for details on memory population guidelines.
2. Push the release tabs outwards on both ends of the DIMM slot to unlock it.
3. Align the key of the DIMM module with the receptive point on the memory slot.
4. Align the notches on both ends of the module against the receptive points on the ends of the slot.
5. Press both ends of the module straight down into the slot until the module snaps into place.
6. Press the release tabs to the lock positions to secure the DIMM module into the slot.



## DIMM Removal

Press both release tabs on the ends of the DIMM module to unlock it. Once the DIMM module is loosened, remove it from the memory slot.

## 3.5 Motherboard Battery

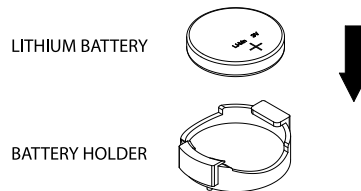
The motherboard uses non-volatile memory to retain system information when system power is removed. This memory is powered by a lithium battery residing on the motherboard.

### ***Replacing the Battery***

Begin by [removing power](#) from the system.

1. Push aside the small clamp that covers the edge of the battery. When the battery is released, lift it out of the holder.
2. To insert a new battery, slide one edge under the lip of the holder with the positive (+) side facing up. Then push the other side down until the clamp snaps over it.

**Note:** Handle used batteries carefully. Do not damage the battery in any way; a damaged battery may release hazardous materials into the environment. Do not discard a used battery in the garbage or a public landfill. Please comply with the regulations set up by your local hazardous waste management agency to dispose of your used battery properly.



**Figure 3-4. Installing the Onboard Battery**

**Warning:** There is a danger of explosion if the onboard battery is installed upside down (which reverses its polarities). This battery must be replaced only with the same or an equivalent type recommended by the manufacturer (CR2032).

## 3.6 Storage Drives

The systems support 24 hot-swap 3.5" SAS3/SATA3. For compatible storage drives, use the [H13SSW motherboard page](#).

The drives are mounted in toolless drive carriers that simplify their removal from the chassis. These carriers also help promote proper airflow.

**Note:** Enterprise level drives are recommended for use in Supermicro chassis and servers. For information on recommended storage drives, visit the Supermicro website product pages at [www.supermicro.com/products](http://www.supermicro.com/products).

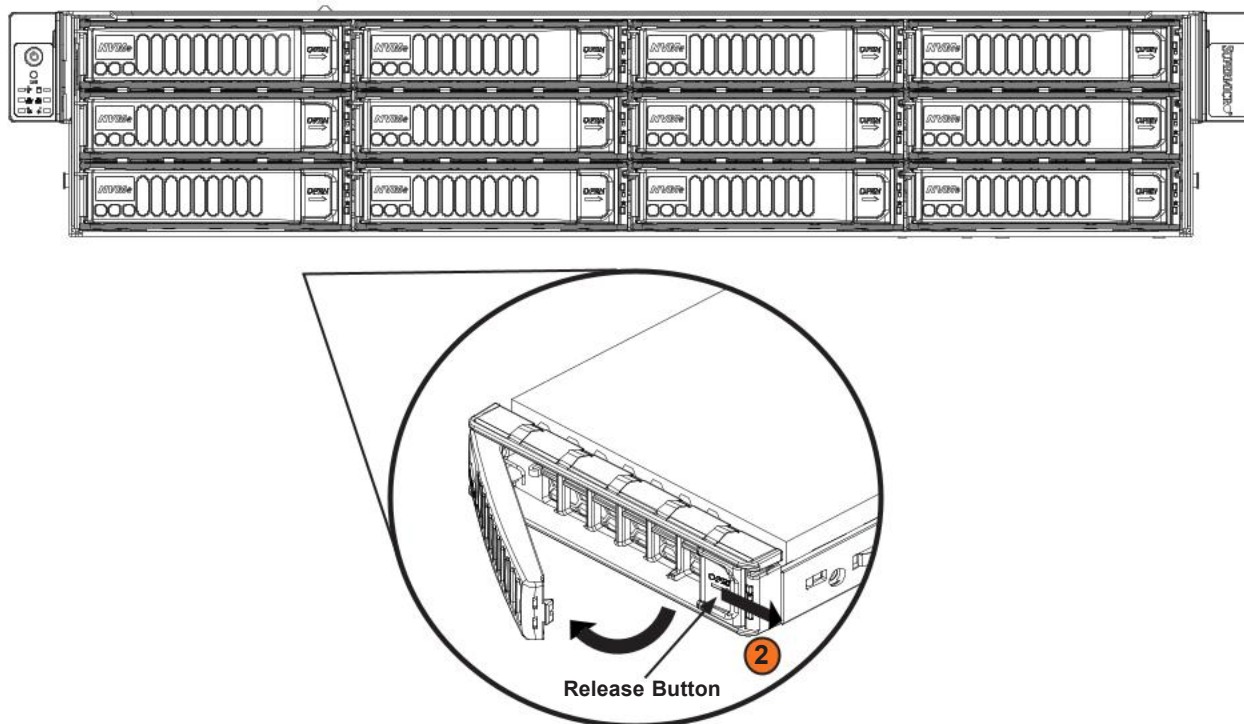
### Installing Drives



Figure 3-5. Logical Drive Numbers

### ***Removing Drive Carriers from the Server***

1. To access mid-chassis drives, open the mid-chassis cover and lift the drive rack.
2. Slide the release button toward the side of the drive carrier, which extends the drive carrier handle.
3. Use the drive carrier handle to pull the drive out of the chassis.



**Figure 3-6. Removing a Drive Carrier**

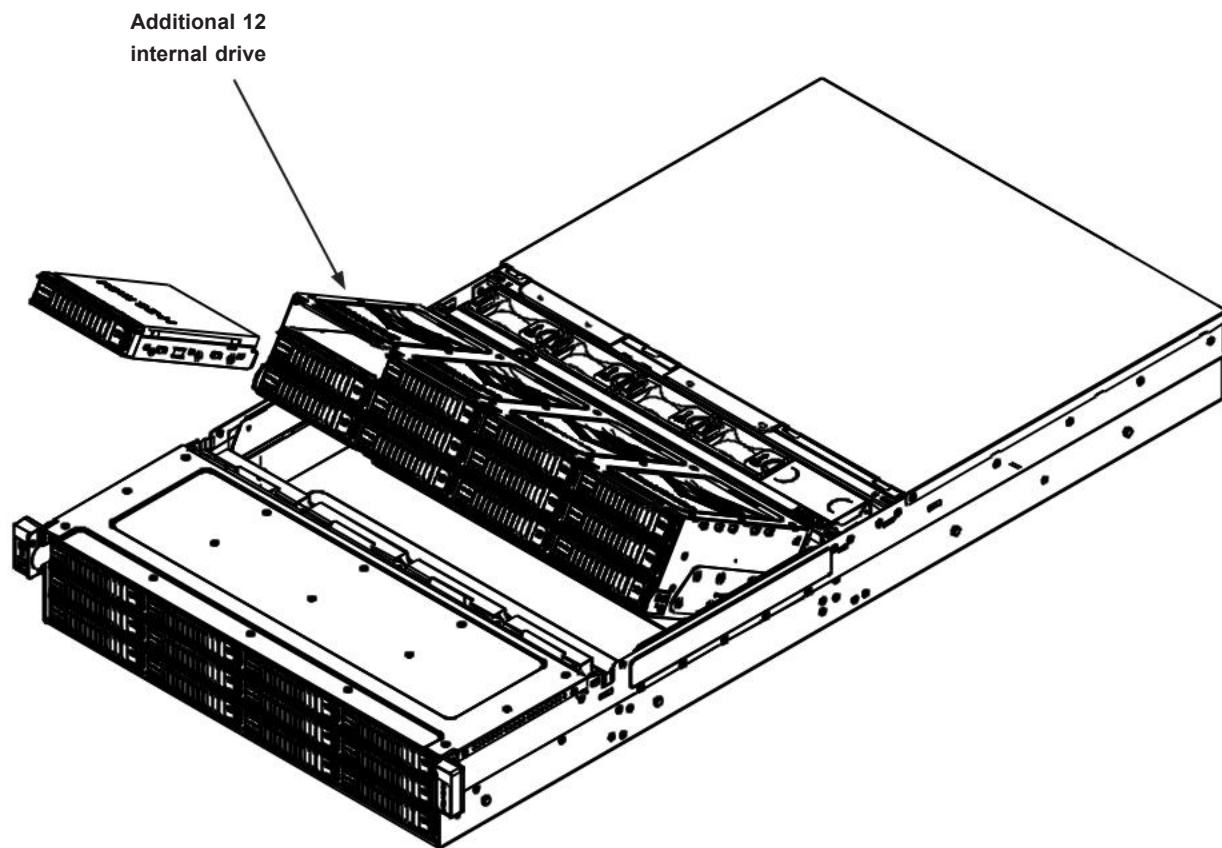
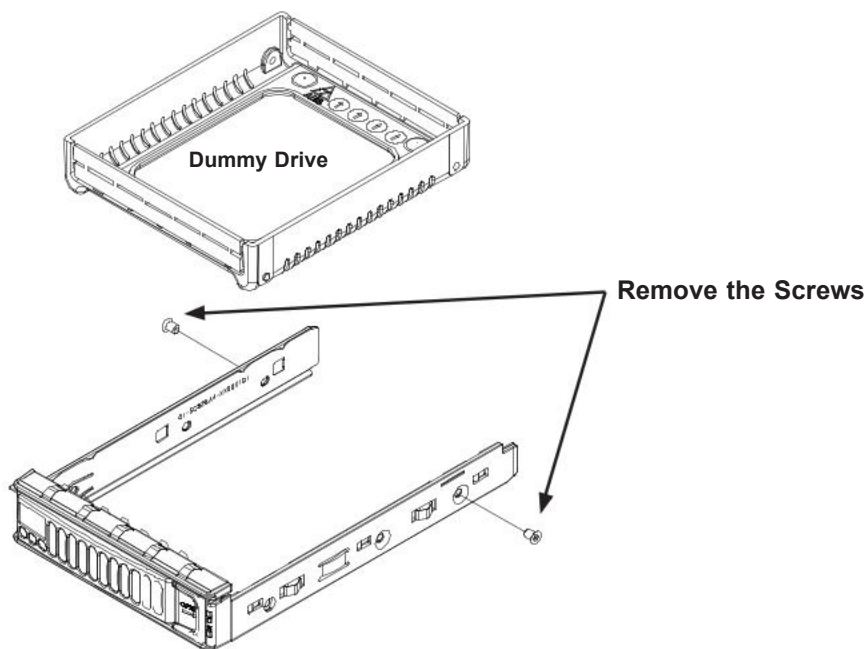


Figure 3-7. Removing Internal Drives

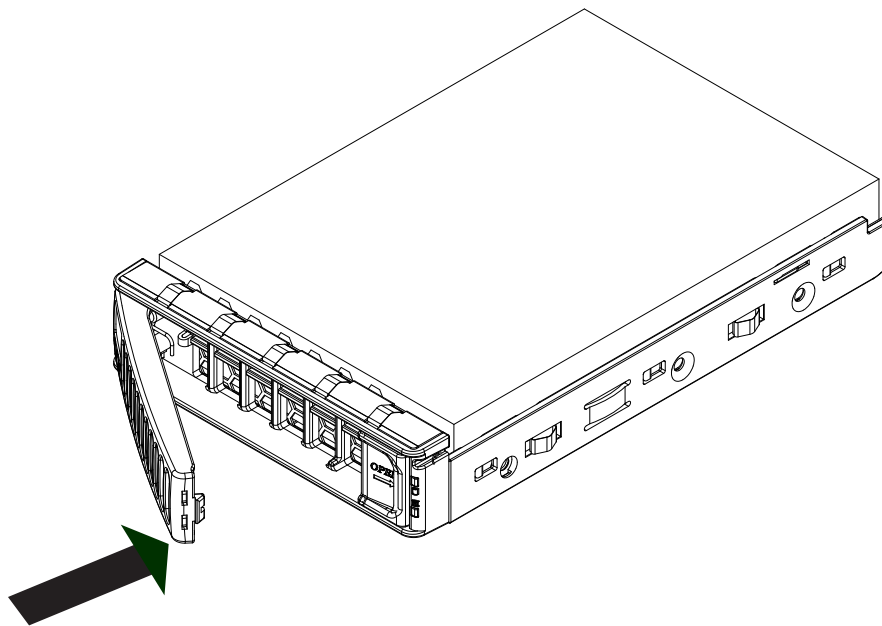
### ***Installing a Drive***

1. Remove the screws securing the dummy drive to the carrier.
2. Remove the dummy drive from the carrier.



**Figure 3-8. Removing a Dummy Drive from the Drive Carrier**

3. Insert the drive into the carrier with the printed circuit board side facing downward and so that the mounting holes in the drive align with those in the carrier.
4. Secure the drive to the carrier with the four screws included with the drive.
5. Insert the drive and carrier into its bay, keeping the carrier oriented so that the release button is on the right. When the carrier reaches the rear of the bay, the release handle will retract.
6. Using the thumb, push the drive carrier handle until it clicks into the locked position.



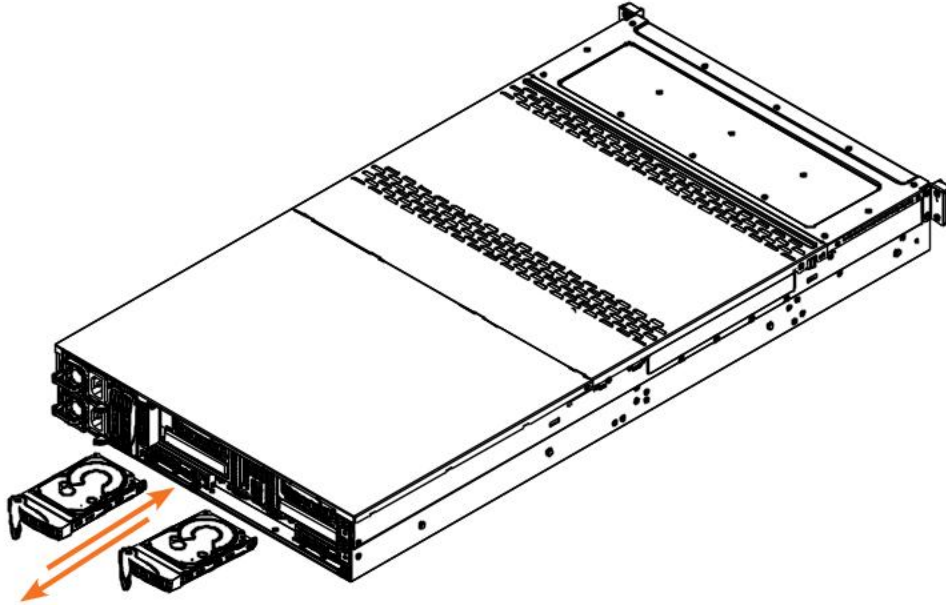
**Figure 3-9. Locking the Drive Carrier into Place**

**Caution:** Except for short periods of time, such as swapping storage drives, do not operate the server with the drive bays empty.

**Note:** Enterprise storage drives are recommended for use in Supermicro chassis and servers. For information on recommended storage drives, visit the Supermicro website at <http://www.supermicro.com/products/nfo/files/storage/SBB-HDDCompList.pdf>

### ***Installing Rear Storage Drives***

The four optional drives and two standard vertically-mounted drives in the rear of the chassis are installed in the same way as the main storage drives.



**Figure 3-10. Installing and Removing a 2.5" Drive**

### Removing a Rear Hot-Swap Drive Carrier from the Server

1. Press the release button on the drive carrier, which will extend the drive carrier handle.
2. Use the drive carrier handle to pull the drive out of the chassis.
3. Two standard vertically-mounted drives in the rear of the chassis are installed in the same way as the main storage drives.

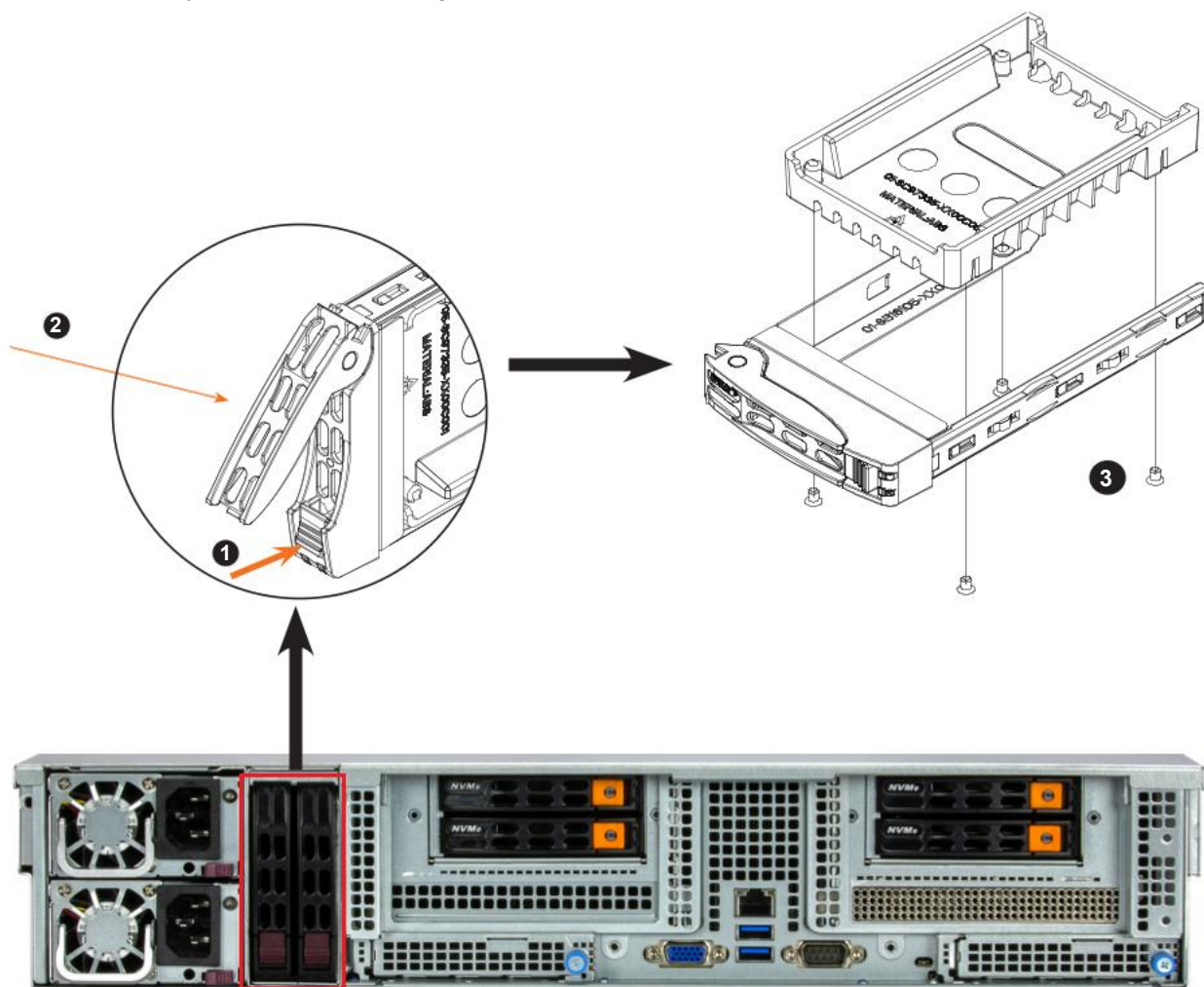
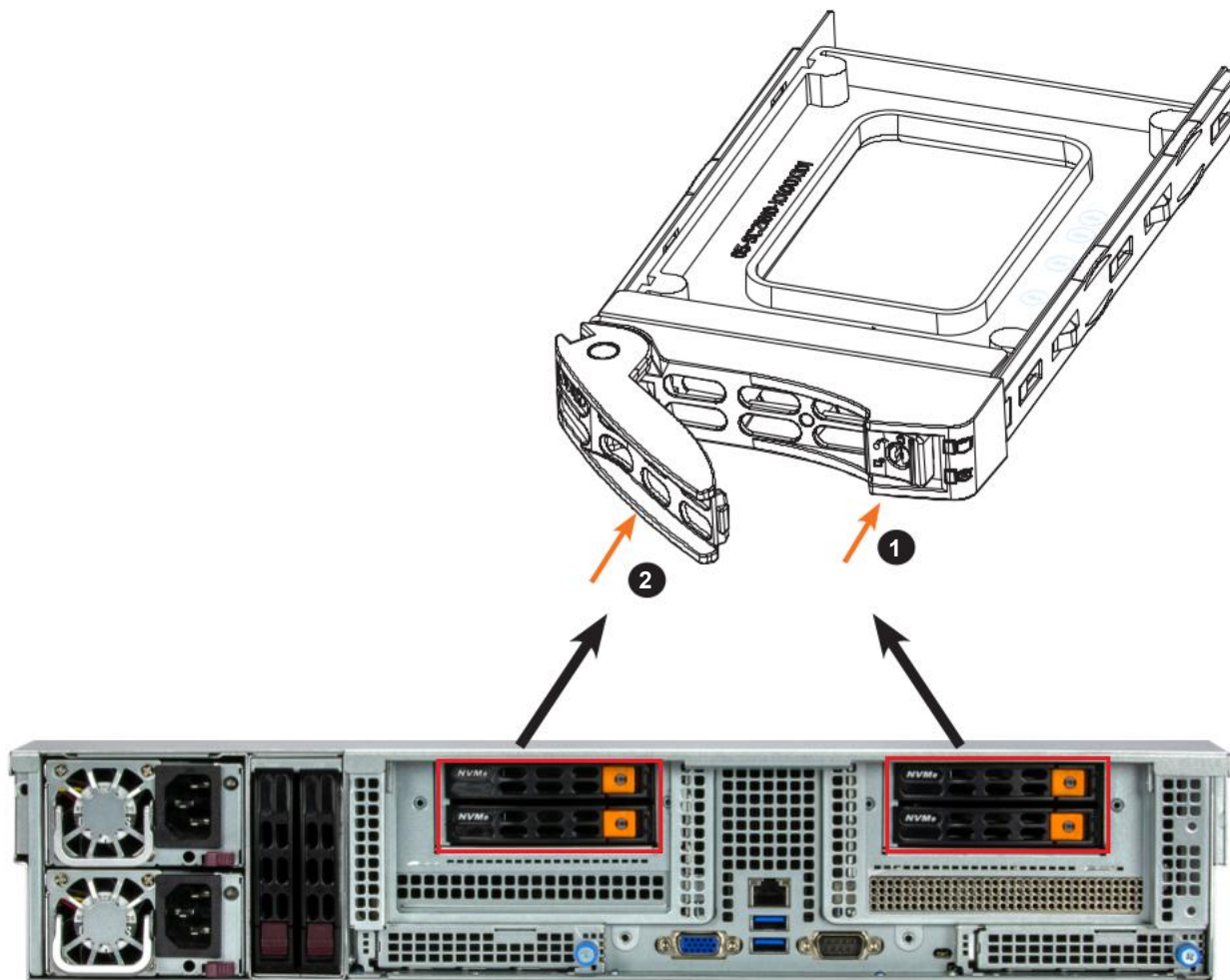


Figure 3-11. Removing a Rear Hot-Swap Drive Carrier

**Removing a Rear Hot-Swap Drive Carrier from the Server**

1. Press the release button on the drive carrier, which will extend the drive carrier handle.
2. Use the drive carrier handle to pull the drive out of the chassis.

**Figure 3-12. Extending the Drive Carrier Handle**

### Installing a Storage Drive

1. Remove the dummy drive, which comes pre-installed in the drive carrier. Pull out the two locking clasps on the left outside of the carrier and lift out the dummy drive.
2. Install the drive directly into the tray and push in the two locking clasps to secure the drive in place.
3. Insert the drive carrier into its bay, keeping the release button on the right. When the carrier reaches the rear of the bay, the release handle will retract. Push the handle in until it clicks into its locked position.

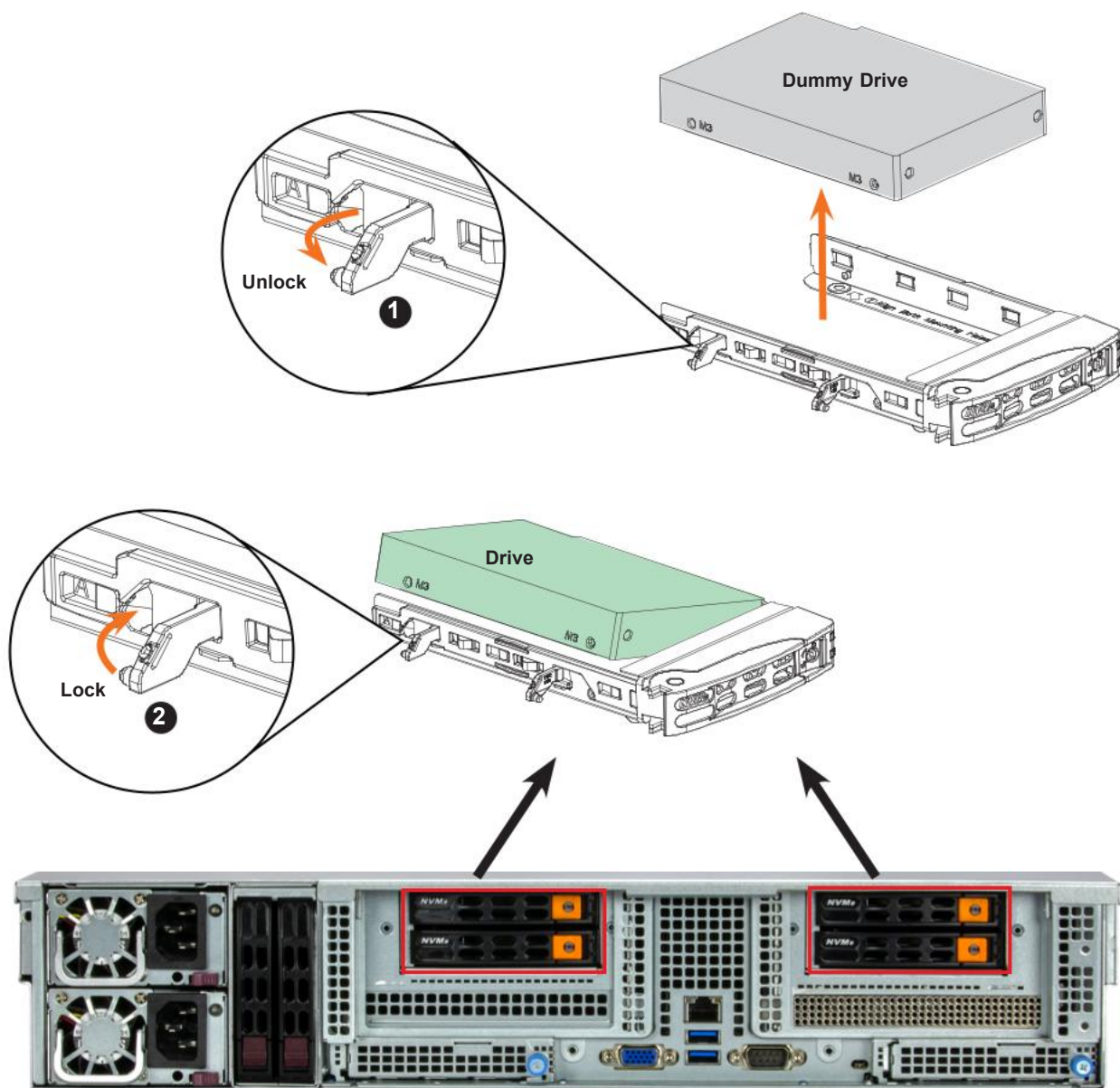


Figure 3-13. Removing a Dummy Drive

## 3.7 System Cooling

Four 8-cm heavy-duty fans provide cooling for the system. They can be replaced without powering down the system.

### *Replacing a System Fan*

1. If necessary, open the chassis while the power is running to determine which fan requires changing. (Never run the server for an extended period of time with the chassis open.)
2. Remove the chassis from the rack and seat it on a work bench (safety area). Open the mid-chassis cover as described earlier in this section.
3. Press the fan release tab to lift the failed fan from the chassis and pull it completely out of the chassis.
4. Place the new fan into the vacant space in the housing while making sure the arrows on the top of the fan (indicating air direction) point in the same direction as the arrows on the other fans.
5. The fan will automatically begin running at the correct speed.

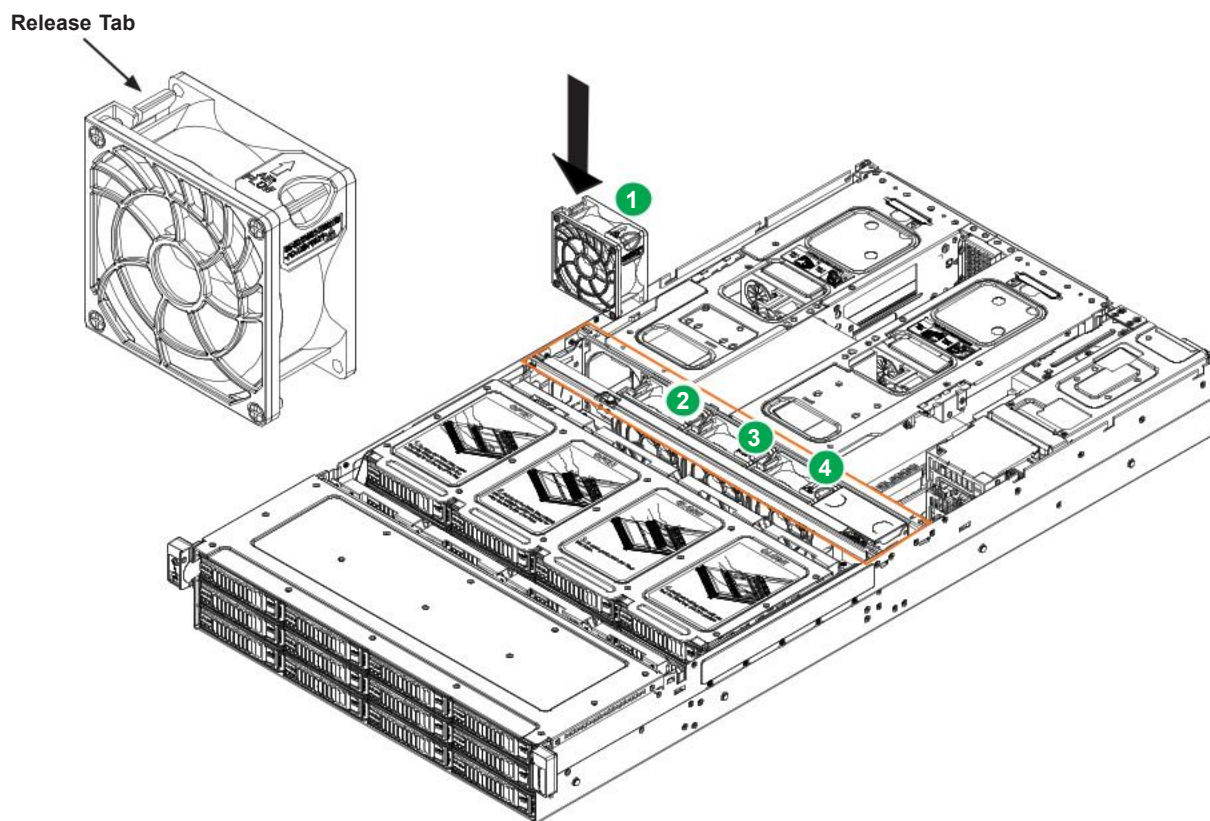
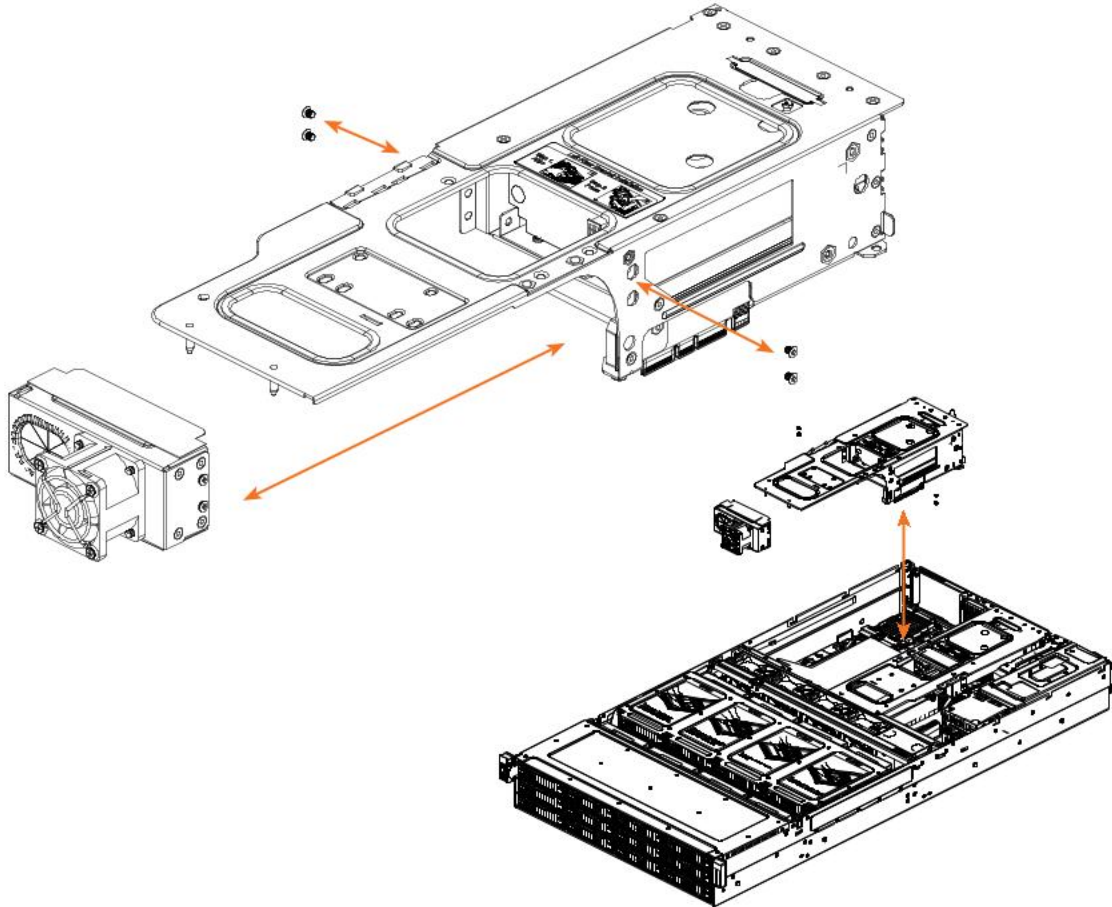


Figure 3-14. Fan Positions



**Figure 3-15. Fan for NVMe Drives**

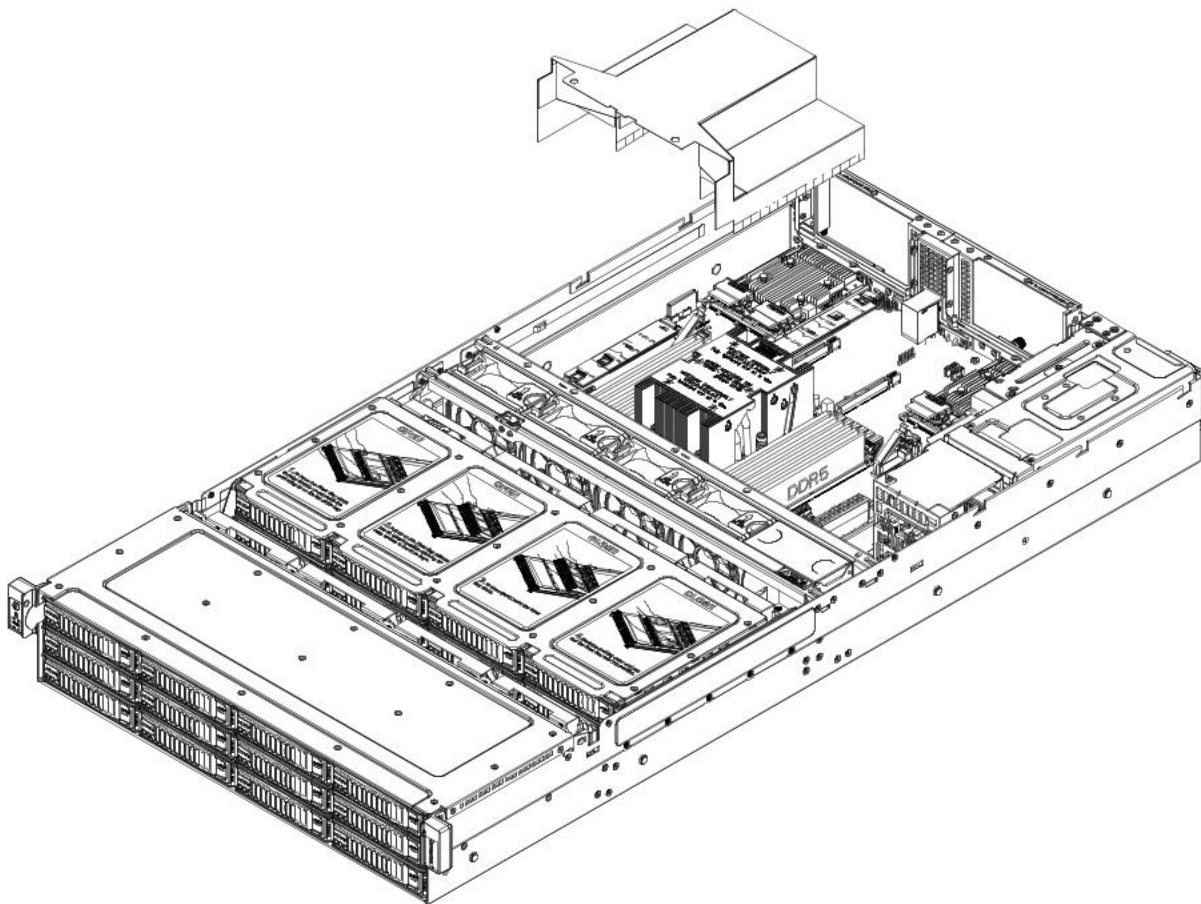
**Note:** Optional system cooling fan for NVMe storage drives. See the [Optional Parts](#) for more details.

## Installing a Air Shroud

Air shrouds concentrate airflow to maximize fan efficiency. They do not require screws for installation.

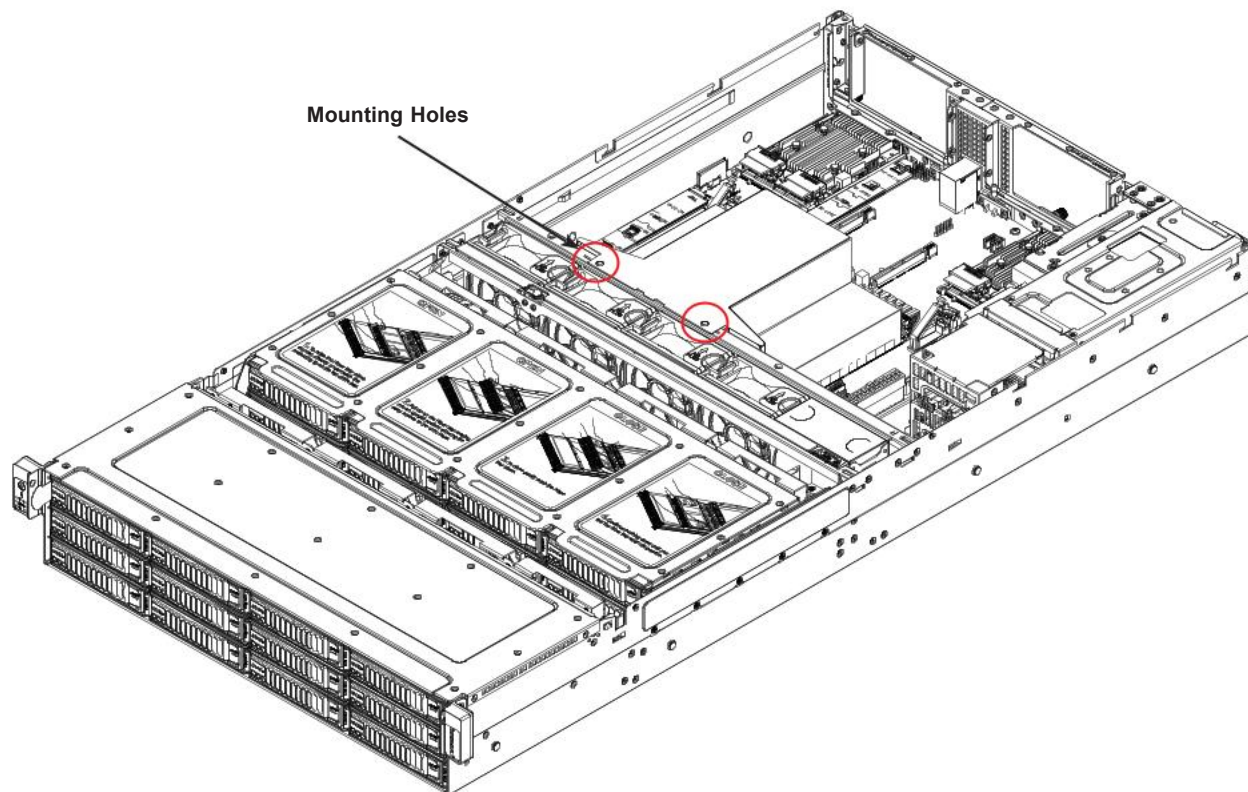
### *Installing a Air Shroud*

1. Power down the system and remove the covers as described earlier in this section.
2. Place the mylar air shroud in the chassis. It fits just behind the fans and under the power supply housing, as shown below.



**Figure 3-16. Mylar Air Shroud Installation**

3. Align the mounting holes in the air shroud with those in the chassis for the riser card bracket to be able to secure it. No screws required.
4. Replace both chassis covers and power up the system.



**Figure 3-17. Air Shroud Installation**

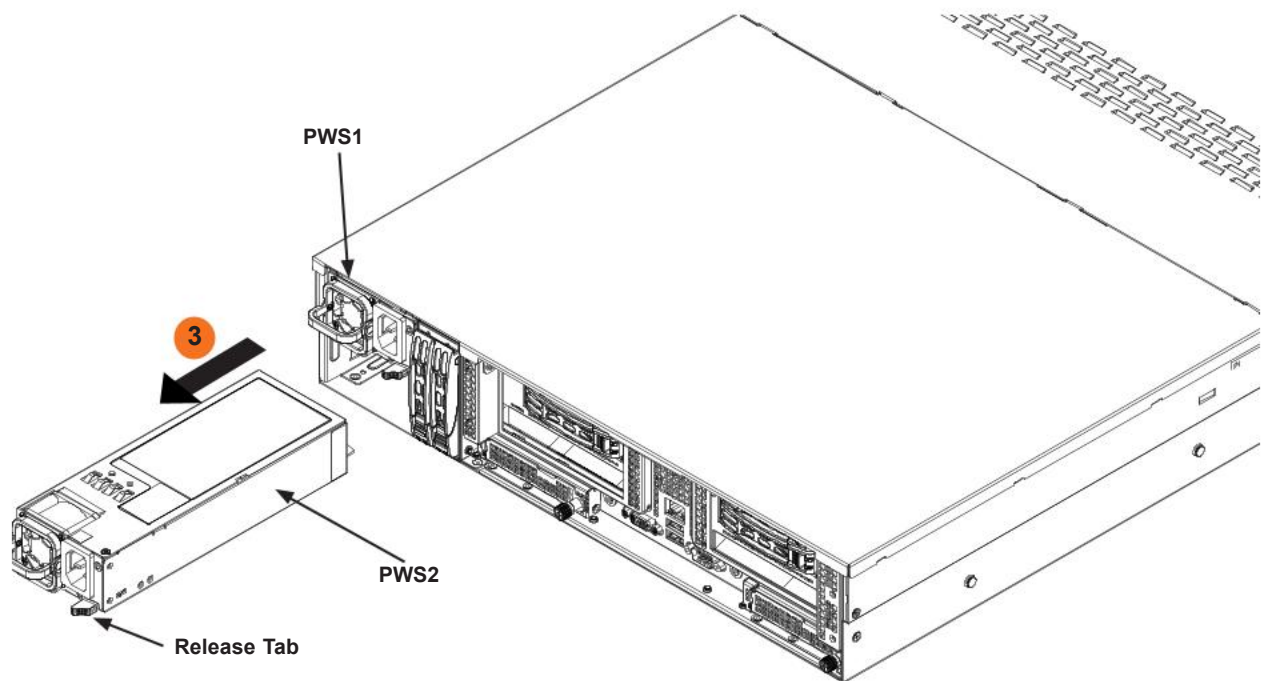
## 3.8 Power Supply

The chassis features redundant 1600 Watt power supplies. The power modules can be changed without powering down the system. New units can be ordered directly from Supermicro or authorized distributors.

These power supplies are auto-switching capable. This feature enables them to automatically sense the input voltage and operate at a 100-120 v or 180-240 v. An amber light will be illuminated on the power supply when the power is off. An illuminated green light indicates that the power supply is operating.

### ***Changing the Power Supply***

1. Unplug the AC cord from the module to be replaced.
2. Push the release tab on the back of the power supply as illustrated.
3. Pull the power supply out using the handle provided.



**Figure 3-18. Power Supply Release Tab**

4. Replace the failed power module with the same model.
5. Push the new power supply module into the power bay until it clicks.
6. Plug the AC power cord back into the module.

### 3.9 PCI Expansion Cards

The ASG -2015S-E1CR24H/ASG -2015S-E1CR24L supports four PCIe 5.0 x16 slots, two PCIe 5.0 x8 slots, and two PCIe 5.0 x16 AIOM slots. The expansion slots will differ depending on the configuration.

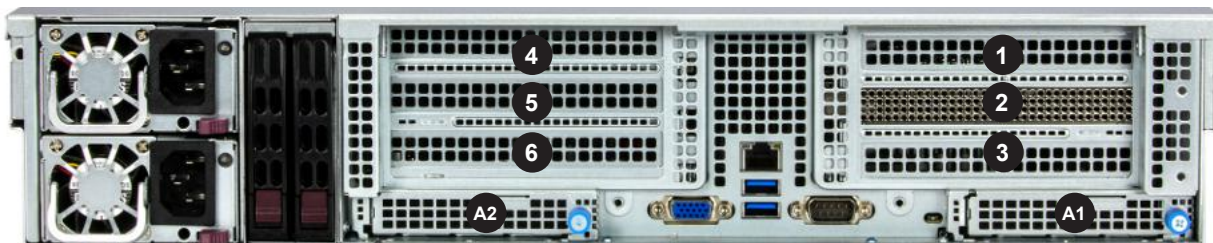


Figure 3-19. Expansion Slots: Standard Configuration



Figure 3-20. Expansion Slots: Configuration B

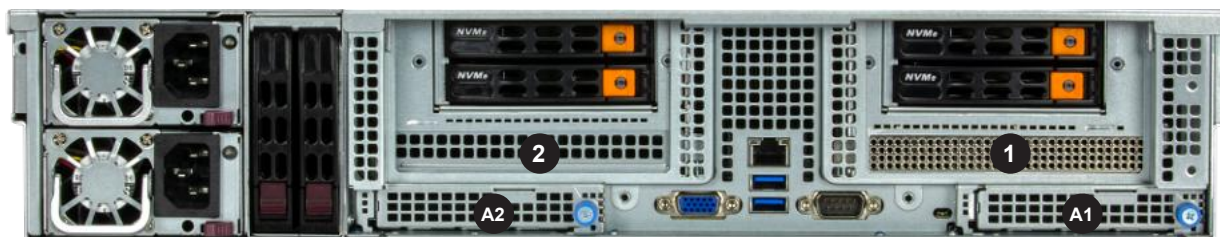


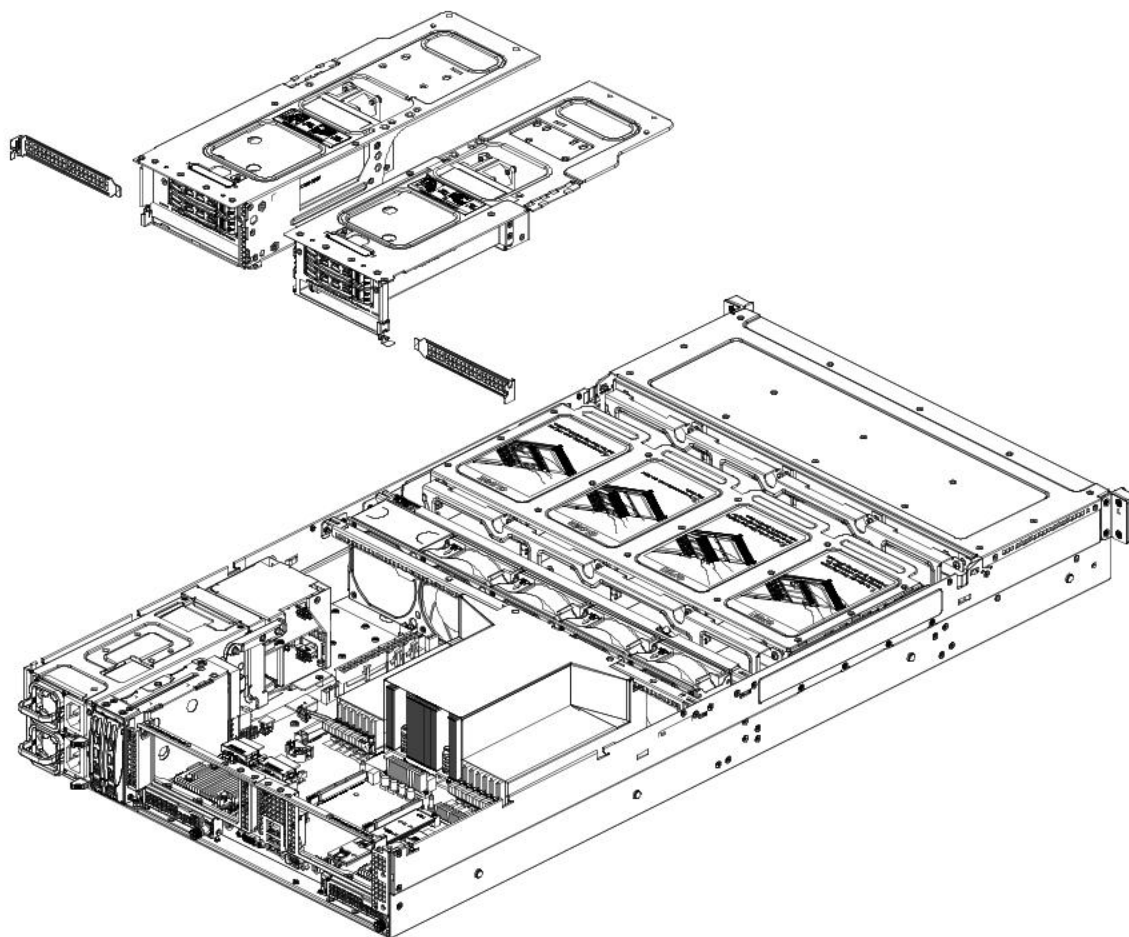
Figure 3-21. Expansion Slots: Configuration C

<b>Expansion Slot Locations</b>			
<b>Slot</b>	<b>Configuration A</b>	<b>Configuration B</b>	<b>Configuration C</b>
<b>1</b>	PCIe 5.0 x16	PCIe 5.0 x16	PCIe 5.0 x16*
<b>2</b>	PCIe 5.0 x8*	PCIe 5.0 x8*	PCIe 5.0 x16
<b>3</b>	PCIe 5.0 x16	PCIe 5.0 x16	N/A
<b>4</b>	PCIe 5.0 x8	PCIe 5.0 x16	N/A
<b>5</b>	PCIe 5.0 x16	N/A	N/A
<b>6</b>	PCIe 5.0 x16	N/A	N/A
<b>A1</b>	PCIe 5.0 x16 AIOM	PCIe 5.0 x16 AIOM	PCIe 5.0 x16 AIOM
<b>A2</b>	PCIe 5.0 x16 AIOM	PCIe 5.0 x16 AIOM	PCIe 5.0 x16 AIOM

\* Occupied by AOC-S3808L-L8IT-P/AOC-S3908L-H8IR-32DD-P SAS controller card.

### ***Installing an Expansion Card***

1. Power down the system as described in section 3.1 and remove the cover.
2. Unscrew and remove the chassis slot cover.
3. Insert the expansion card into a slot on the motherboard while aligning the expansion card backplate with the open slot in the rear of the chassis. Secure with a screw.
4. Replace the cover and power the system back on.



**Figure 3-22. Installing an Expansion Card**

## Installing an AIOM Card

The AIOM card provides options for network connection. It is inserted into an AIOM slot on the motherboard. This installation is usually performed by a system integrator or manufacturer.

### *Installing an AIOM Card*

1. Power down the system as described earlier in this section.

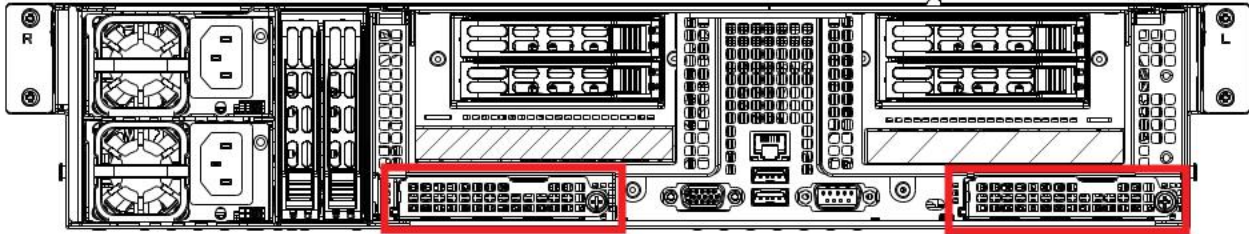


Figure 3-23. AIOM Card Position on Chassis Rear

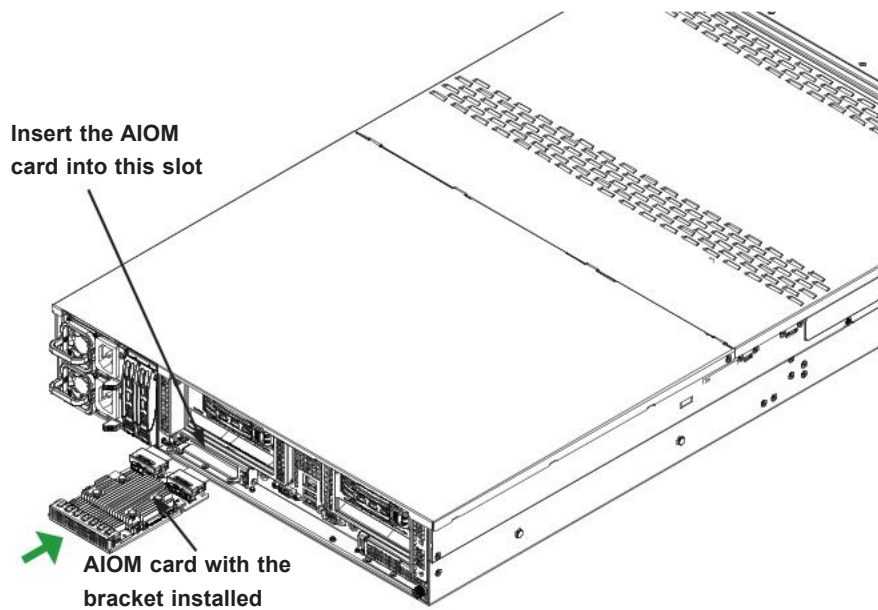


Figure 3-24. Inserting AIOM Card

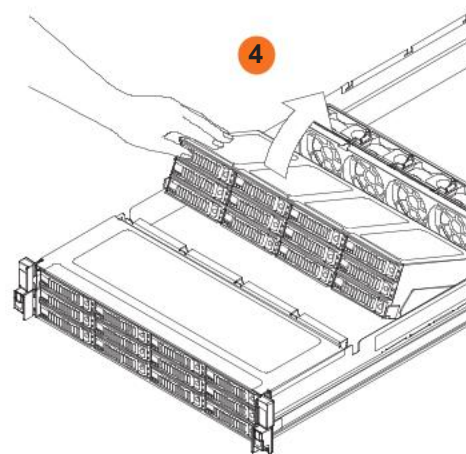
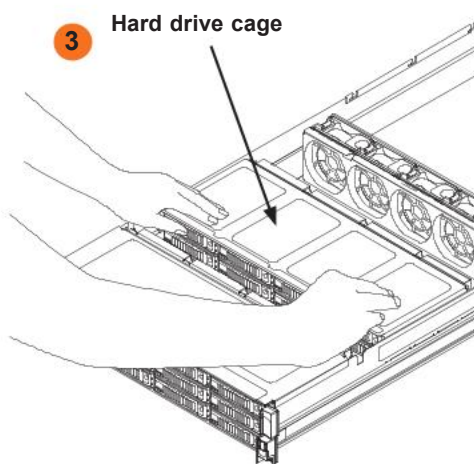
2. Remove the small section of the chassis rear to allow access to the motherboard AIOM slot. Unscrew the single retaining screw to remove the cover.
3. Position the card with its cover bracket in front of the AIOM slot and gently push in both sides of the card until it slides into the slot.
4. Secure the AIOM card cover bracket to the chassis with the screw.

## Installing Internal Drives

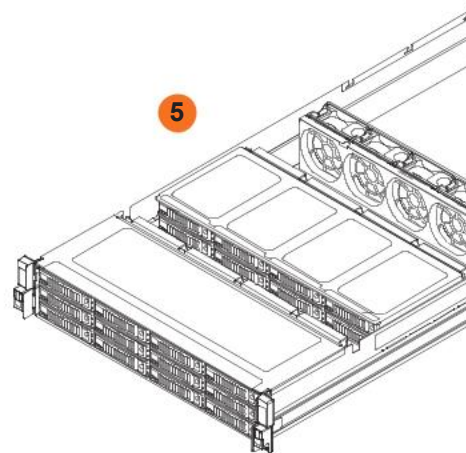
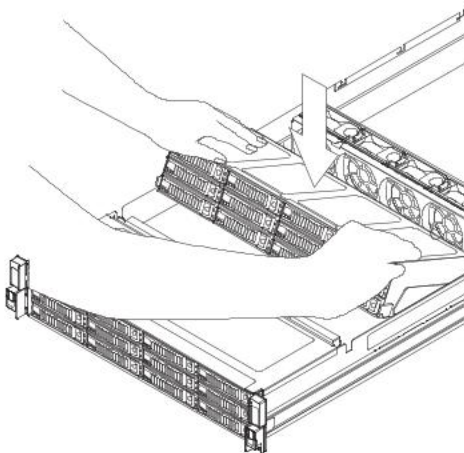
Internally-mounted 3.5" drives can be installed in the chassis. Removing the server from the rack is required for this installation.

### *Installing the Internal 3.5" Drives*

1. In step one, shutting down the power should come before removing the chassis from the rack and putting it on a bench. Follow the steps for shutting down power and removing the mid-chassis cover from the system from Sections 3.1 and 3.2.
2. After removing the mid chassis cover, you will see the hard drive cage for the hard drives.



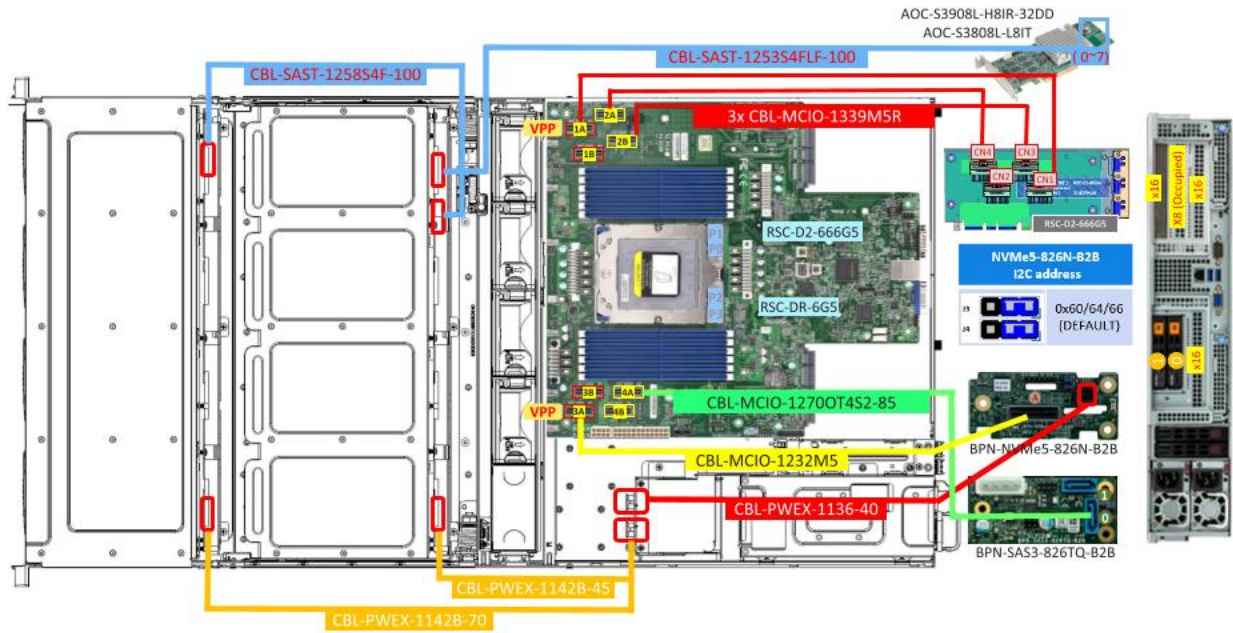
3. To raise the hard drive cage, place thumbs directly underneath the protruding lip on top of the cage.
4. Pull up on the hard drive cage as seen on the illustration for easy access to the drive bays.



5. After installing the hard drives, gently reseat the drive cage into position in the chassis.

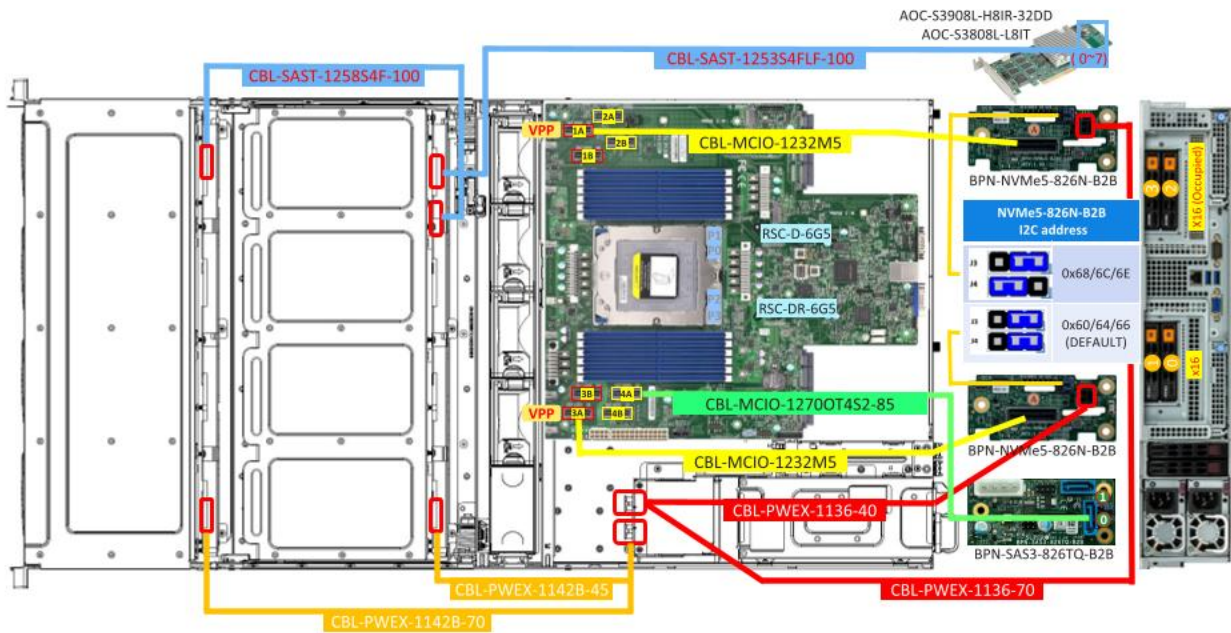


## H13 Cable Plan - 2U 24 Simply Double (Support 2x NVMe)



## H13 Cable Plan - 2U 24 Simply Double (Support 4x NVMe)

- 24x 3.5" SAS3/SATA3, 2x 2.5" SATA3, 4x Gen5 U.2 NVMe, 4x PCIe x16



## Cables

Con	CBL	BPN	Notes
1A	CBL-MCIO-1339M5R	RSC-D2-666G5	CN1 39cm
2A	CBL-MCIO-1339M5R		CN3 39cm
2B	CBL-MCIO-1339M5R		CN4 39cm
3B	CBL-MCIO-1339M5R	RSC-D2R-666G5	CN1 39cm
3A	CBL-MCIO-1339M5R		CN2 39cm
1B	CBL-MCIO-1339M5R		CN4 39cm
4A	CBL-MCIO-12700T4S2-85	BPN-SAS3-826TQ-B2B	CN1 CN2 70cm
3908/3808	CBL-SAST-1258S4FL-100	BPN-SAS3-826SE1	CN2 59cm
BPN-SAS3-826SE1	CN3 CBL-SAST-1258S4F-100	BPN-SAS3-826SA	CN1 58cm
PDB micro-hi	CBL-PWEX-1142B-45	BPN-SAS3-826SE1	45cm
PDB micro-hi	CBL-PWEX-1142B-70	BPN-SAS3-826SA	70cm
1A	CBL-MCIO-1232M5	BPN-NVMe5-826N-B2B	NVMe add-on #1
PDB micro-hi	CBL-PWEX-1136-40	BPN-NVMe5-826N-B2B	
3A	CBL-MCIO-1232M5	BPN-NVMe5-826N-B2B	NVMe add-on #2
PDB micro-hi	CBL-PWEX-1136-70	BPN-NVMe5-826N-B2B	

## Chapter 4

# Motherboard Connections

This section describes the jumpers, connections and LEDs on the motherboard and provides pinout definitions. Some connections might not be used in this system. A motherboard layout indicating component locations may be found in [Chapter 1](#). More details can be found in the [Motherboard Manual](#).

### 4.1 Power Connections

#### 12 V 8-pin Auxiliary Power Connector (JPWR2)

JPWR2 is an 8-pin ATX power input to provide auxiliary power to the processor. Refer to the table below for pin definitions.

12 V 8-pin Power Connector Pin Definitions			
Pin#	Definition	Pin#	Definition
1	Ground	5	+12 V
2	Ground	6	+12 V
3	Ground	7	+12 V
4	Ground	8	+12 V

#### Main Power Supply Connector (JPWR3)

The primary power supply connector (JPWR3) is an ATX power connector that the power supply plugs into directly.

Power Supply Connector Pin Definitions			
Pin#	Definition	Pin#	Definition
1	+3.3 V	13	+3.3 V
2	+3.3 V	14	-12 V
3	Ground	15	Ground
4	+5 V	16	PS_ON
5	Ground	17	Ground
6	+5 V	18	Ground
7	Ground	19	Ground
8	PWR_OK	20	Res (NC)
9	5 VSB	21	+5 V
10	+12 V	22	+5 V
11	+12 V	23	+5 V
12	+3.3 V	24	Ground

### NVMe Ports (NVMe 0-11)

The H13SSW has twelve NVMe ports (2 ports per 1 MCIO x 8). These ports provide high speed and low latency directly from the CPU to NVMe Solid State drives (SSD). This greatly increases SSD data-throughput performance and significantly reduces PCIe latency by simplifying driver/software requirements resulting from direct PCIe interface from the CPU to the NVMe SSD drives.

### SATA/NVMe Hybrid Ports (NVMe12-15, SATA 0-15)

Each SATA/NVMe hybrid port can support up to eight SATA 3.0 ports or two NVMe ports (PCIe x4), for a total of 16 SATA ports or four NVMe ports.

### PCIe M.2 Connectors (M.2-C1, M.2-C2)

The PCIe M.2 connectors are for devices such as memory cards, wireless adapters, etc. These devices must conform to the PCIe M.2 specifications (formerly known as NGFF). These particular PCIe M.2 connectors support M-Key (PCIe x2) storage cards. M.2-C1 and M.2-C2 can support a speed of PCIe 3.0.

### TPM/Port 80 Header

A Trusted Platform Module (TPM)/Port 80 header is located at JTPM1 to provide TPM support and Port 80 connection. Use this header to enhance system performance and data security. Refer to the table below for pin definitions. Please go to the following link for more information on the TPM: <http://www.supermicro.com/manuals/other/TPM.pdf>.

Trusted Platform Module Header Pin Definitions			
Pin#	Definition	Pin#	Definition
1	+3.3 V	2	SPI_CS#
3	RESET#	4	SPI_MISO
5	SPI_CLK	6	GND
7	SPI_MOSI	8	NC
9	+1.8 V Stdbby	10	SPI_IRQ#

## USB Ports (USB0/1)

There are a total of four USB ports supported on the motherboard. Two are located on the front panel, and two are located on the back panel.

Front Panel USB 0/1 (2.0) Pin Definitions			
Pin#	Definition	Pin#	Definition
1	+5 V	2	+5 V
3	USB7_N	4	USB8_N
5	USB7_P	6	USB8_P
7	Ground	8	Ground
9	Key	10	USB_OC#

## Expansion Slots

The motherboard features several expansion slots. The table below describes each slot's type and speed.

Expansion Slots	
Name	Description
<b>LWIO</b>	Left-hand riser card slot supports PCIe 5.0 x16
<b>RWIO</b>	Right-hand riser card slot supports PCIe 5.0 x16
<b>AIOM1</b>	AIOM (Advanced I/O Module) supports PCIe 5.0 x16 with NCSI
<b>AIOM2</b>	AIOM (Advanced I/O Module) supports PCIe 5.0 x16

## Onboard Battery (BT1)

The onboard back up battery is located at BT1. The onboard battery provides backup power to the on-chip CMOS, which stores the BIOS' setup information. It also provides power to the Real Time Clock (RTC) to keep it running.

## Chassis Intrusion (JL1)

A Chassis Intrusion header is located at JL1 on the motherboard. Attach the appropriate cable from the chassis to the header to inform you when the chassis has been opened.

Chassis Intrusion Pin Definitions	
Pins	Definition
1	Intrusion Input
2	Ground

## 4.2 Headers

### Power SMB Header (PWRI2C)

Power System Management Bus (I<sup>2</sup>C) header monitors power supply, fan, and system temperatures. See the table below for pin definitions.

Power SMB Header Pin Definitions	
Pin#	Definition
1	Clock
2	Data
3	Alert
4	Ground
5	+3.3 V

### 4-pin External BMC I2C Header

A System Management Bus header for IPMI 2.0 is located at JIPMB1. Connect a cable to this header to use the IPMB I<sup>2</sup>C connection on your system. Refer to the table below for pin definitions.

External I <sup>2</sup> C Header Pin Definitions	
Pin#	Definition
1	Data
2	Ground
3	Clock
4	+3.3 V Stdby

## 4.3 Rear I/O Ports

See Figure 4-1 below for the locations and descriptions of the various I/O ports on the rear of the motherboard.

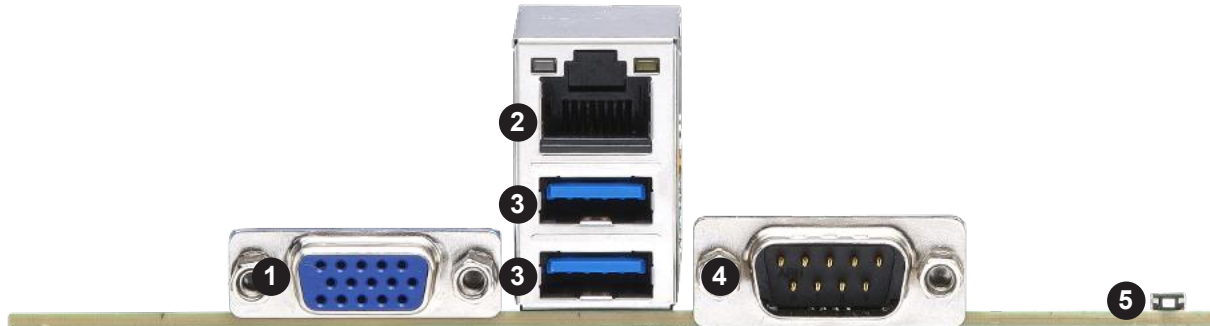


Figure 4-1. I/O Port Locations and Definitions

Rear I/O Ports			
#	Description	#	Description
1	VGA Port	4	COM Port
2	IPMI LAN Port	5	UID Switch & UID LED
3	USB Ports (USB 3.0)		

### 1. VGA Port

There is one VGA port on the rear I/O panel.

### 2. IPMI LAN Port

One dedicated IPMI LAN port is located on the rear I/O panel. This port accepts an RJ45 type cable.

### 3. Universal Serial Bus (USB) Ports

There are two USB 3.0 ports on the rear I/O panel. These support the type A connector.

### 4. COM Port

One serial communication (COM) port is included on the rear I/O panel.

### 5. UID Switch & UID LED

A Unit Identifier (UID SW) switch and UID LED (LED8) are located on the I/O backpanel. The rear UID LED (LED8) is located next to the UID switch. When you press the UID switch, both rear and front UID LED indicators will turn on. Press the UID switch again to turn off the LED indicators. The UID Indicator provides easy identification of a system that may be in need of service.

**Note:** UID can also be triggered via IPMI on the serverboard. For more information on IPMI, please refer to the IPMI User's Guide posted on our website at <http://www.supermicro.com>.

## 4.4 Front Control Panel

JF1 contains header pins for various buttons and indicators that are normally located on a control panel at the front of the chassis. These connectors are designed specifically for use with Supermicro chassis. See the figure below for the location of JF1.

	1	2	
Power Switch	○	○	Ground
Reset Switch	○	○	Ground
Power Fail LED+	○	○	Power Fail LED-
UID LED+	○	○	UID LED-
NIC2 Link LED+	○	○	NIC2 Link LED-
NIC1 Link LED+	○	○	NIC1 Link LED-
HDD LED+/UID Switch+	○	○	HDD LED-
PWR LED+	○	○	PWR_LED-
Key, no pin	○	○	Key, no pin
NMI Switch	○	○	Ground
	19	20	

Figure 4-2. JF1 Pin Definitions

## 4.5 Front Control Panel

### NMI Button

The non-maskable interrupt button header is located on pins 19 and 20 of JF1. Refer to the table below for pin definitions.

NMI Button Pin Definitions (JF1)	
Pin#	Definition
19	NMI Switch
20	Ground

### Power LED

The Power LED connection is located on pins 15 and 16 of JF1. Refer to the table below for pin definitions.

Power LED Pin Definitions (JF1)	
Pin#	Definition
15	PWR_LED+
16	PWR_LED-

### Drive Activity LED

The Drive Activity LED is located on pins 13 and 14 of JF1. Attach a drive LED cable here to display activity detected on the motherboard's built-in controllers. See the table below for pin definitions.

Drive Activity LED Pin Definitions (JF1)	
Pin#	Definition
13	Drive Activity LED+/UID Switch+
14	DriveActivity_LED-

### NIC1/NIC2 Link LED

The NIC (Network Interface Controller) LED connection for LAN port 1 is located on pins 11 and 12 of JF1, and the LED connection for LAN Port 2 is on pins 9 and 10. Attach the NIC LED cables to display network activity. Refer to the table below for pin definitions.

NIC1/NIC2 LED Pin Definitions (JF1)	
Pin#	Definition
9/11	NIC Link LED+
10/12	NIC Link LED-

## UID LED

The UID LED is on pins 7 and 8 of JF1. Connect the front panel UID LED to this header to indicate when the rear UID switch is turned on. Refer to the table below for pin definitions.

UID LED Pin Definitions (JF1)	
Pin#	Definition
7	UID LED+
8	UID LED-

## Power Fail LED

The Power Fail LED connection is located on pins 5 and 6 of JF1. Refer to the table below for pin definitions.

Power Fail LED Pin Definitions (JF1)	
Pin#	Definition
5	Power Fail LED+
6	Power Fail LED-

## Reset Button

The Reset Button connection is located on pins 3 and 4 of JF1. Attach the hardware reset switch from the computer case to this header to reset the system. Refer to the table below for pin definitions.

Reset Button Pin Definitions (JF1)	
Pin#	Definition
3	Reset Switch
4	Ground

## Power Button

The Power Button connection is located on pins 1 and 2 of JF1. Momentarily contacting both pins will power on/off the system. This button can also be configured to function as a suspend button. To turn off the power in the suspend mode, press the button for at least 4 seconds. Refer to the table below for pin definitions.

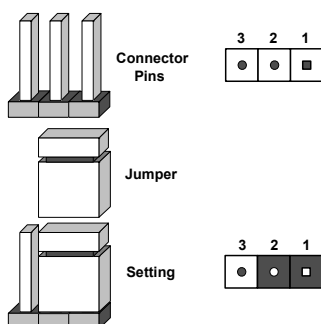
Power Button Pin Definitions (JF1)	
Pin#	Definition
1	Power Switch
2	Ground

## 4.6 Jumpers

### *Explanation of Jumpers*

To modify the operation of the motherboard, jumpers are used to choose between optional settings. Jumpers create shorts between two pins to change the function associated with it. Pin 1 is identified with a square solder pad on the printed circuit board.

**Note:** On a two-pin jumper, "Closed" means the jumper is on both pins and "Open" indicates the jumper is either on only one pin or has been completely removed.



### **JSATA1**

This 3-pin power connector at JSATA1 provides power from the motherboard to internal SATA storage drive or SSD device. Refer to the table below for pin definitions.

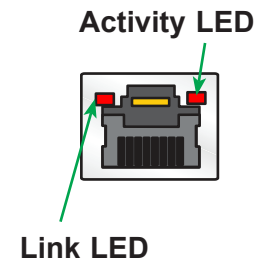
<b>JSATA1 Pin Definitions</b>	
<b>Pin#</b>	<b>Definition</b>
1-2	Auto (Default)
2-3	Force SATA

## 4.7 LED Indicators

### BMC LAN Port LEDs

A dedicated BMC LAN is located on the rear I/O panel and has two LED indicators. The LED on the right indicates connection and activity, while the LED on the left indicates the speed of connection. The Link LED may amber, green, or off to indicate the speed of the connection. Refer to the tables below for more information.

Link LED, Connection Link Speed Indicator	
LED Color	Definition
Amber	1 Gb/s
Green	100 Mb/s
Off	10 Mb/s



Activity LED		
Color	State	Definition
None	No Connection	No Connection
Yellow	Solid On	Link
Yellow	Flashing	Active

### UID LED Indicator (LED8)

The rear LED8 is located next to the UID switch. The front UID LED is located on the front panel. When you press the UID switch, both rear LED8 and front UID LED indicators will turn on. Press the UID switch again to turn off the LED indicators. Use this UID Indicator to 'mark' the system, so the system can be easily identified whether on the front or back (e.g., a system rack with multiple units installed).

UID LED Indicator		
Color	State	Definition
None	Off	UID Off
Blue	Solid On	Unit Identified by Local Site
Blue	Slow Blinking	Unit Identified by Remote Site
Blue	Slow Blinking	System Recovery

### BMC Heartbeat LED (LED1)

A BMC Heartbeat LED is located at LED1 on the motherboard. When LED1 is blinking, the BMC is functioning normally. See the table below for more information.

BMC Heartbeat LED State		
Color	State	Definition
Green	Solid On	BMC is not ready
Green	Blinking	BMC Normal
Green	Fast Blinking	BMC: Initializing

**Onboard Power OK LED (LED7)**

LED7 is an onboard power OK LED. When this LED7 is lit, it means the system is turned on and all the system power rails are ready. When the system is turned off or any one of the system power rails fail, this LED will turn off. Turn off the system and unplug the power cable before removing or installing any component(s).

Onboard Power LED Indicator		
LED Color	State	Definition
None	Off	System Off
Green	Solid On	System On
Green	Blinking	System Recovery

## Chapter 5

### Software

After the hardware has been installed, you can install the Operating System (OS), configure RAID settings and install the drivers.

#### 5.1 Microsoft Windows OS Installation

If you will be using RAID, you must configure RAID settings before installing the Windows OS and the RAID driver. Refer to the RAID Configuration User Guides posted on our website at [www.supernmicro.com/support/manuals](http://www.supernmicro.com/support/manuals).

##### *Installing the OS*

1. Create a method to access the MS Windows installation ISO file. That might be a USB flash or media drive, or the BMC KVM console.
2. Boot from a bootable device with Windows OS installation. You can see a bootable device list by pressing **F11** during the system startup.

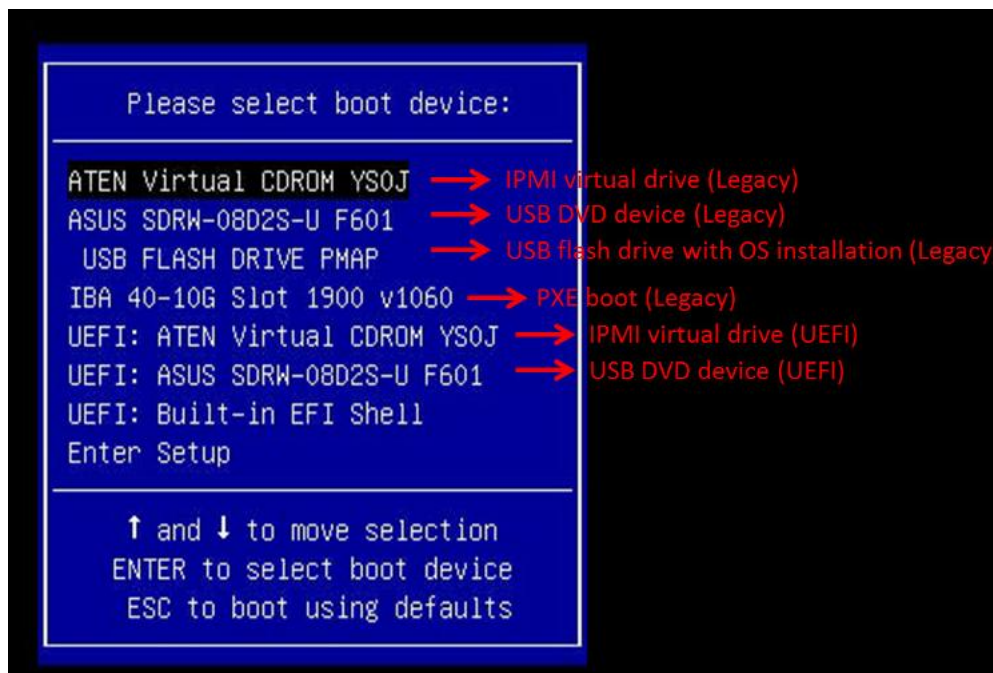
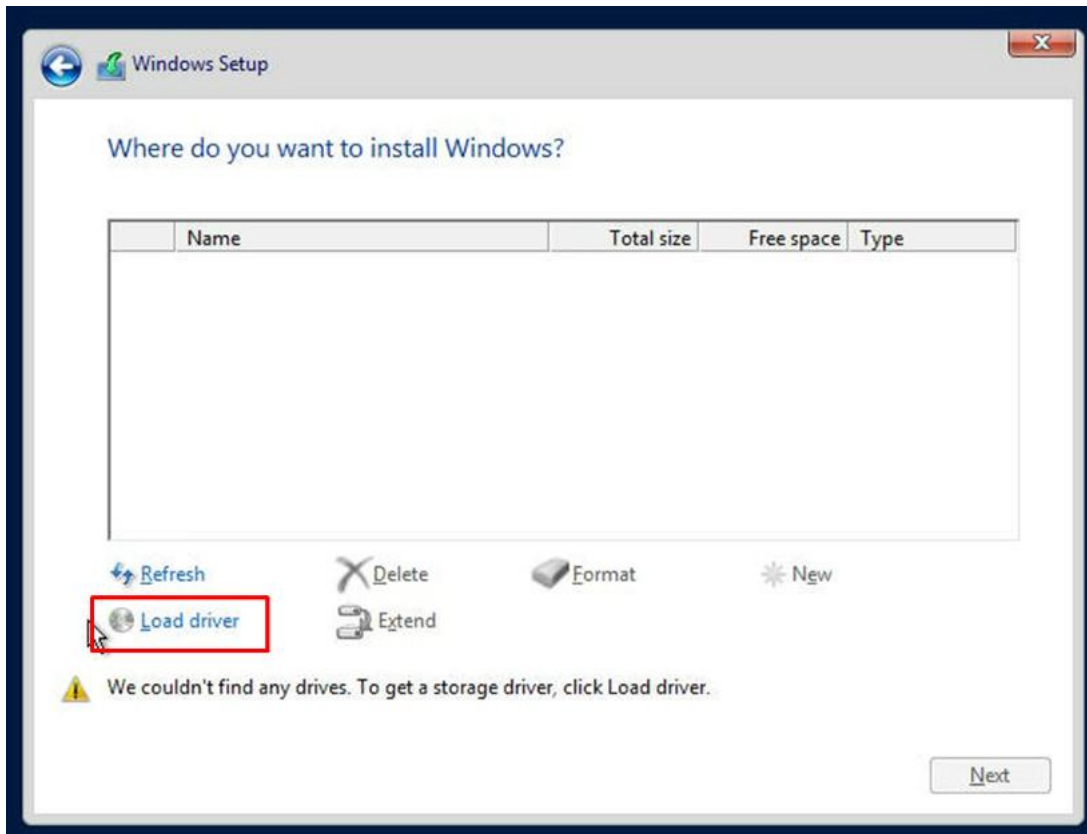


Figure 5-1. Select Boot Device

3. During Windows Setup, continue to the dialog where you select the drives on which to install Windows. If the disk you want to use is not listed, click on “Load driver” link at the bottom left corner.



**Figure 5-2. Load Driver Link**

To load the driver, browse the USB flash drive for the proper driver files.

- For RAID, choose the SATA/sSATA RAID driver indicated then choose the storage drive on which you want to install it.
  - For non-RAID, choose the SATA/sSATA AHCI driver indicated then choose the storage drive on which you want to install it.
4. Once all devices are specified, continue with the installation.
  5. After the Windows OS installation has completed, the system will automatically reboot multiple times.

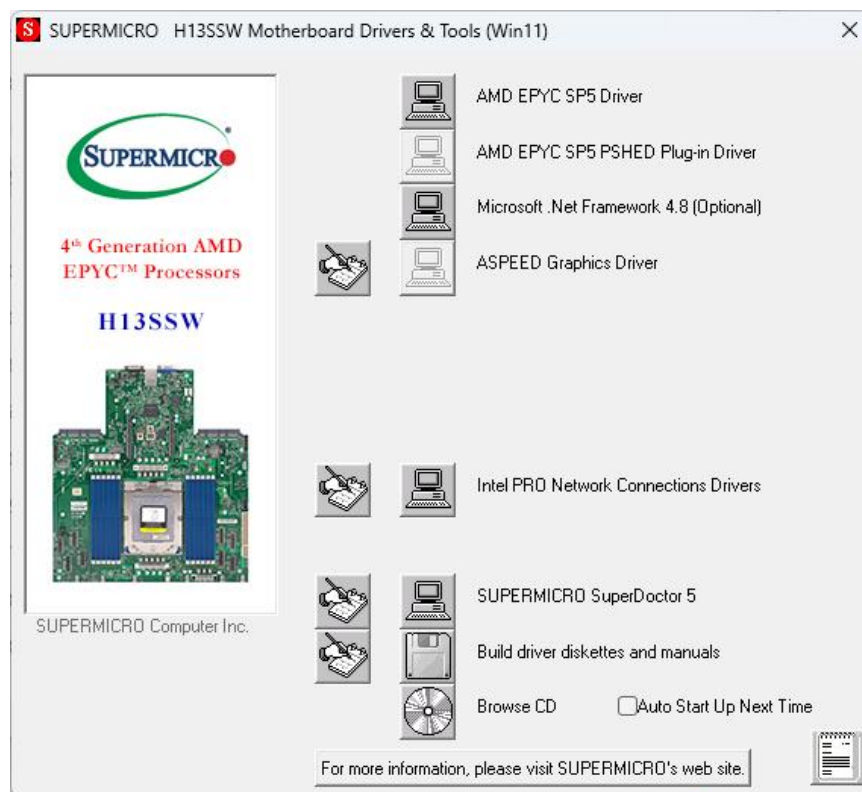
## 5.2 Driver Installation

The Supermicro website contains drivers and utilities for your system at <https://www.supermicro.com/wdl/driver>. Some of these must be installed, such as the chipset driver.

After accessing the website, go into the CDR\_Images (in the parent directory of the above link) and locate the ISO file for your motherboard. Download this file to a USB flash drive or media drive. (You may also use a utility to extract the ISO file if preferred.)

Another option is to go to the Supermicro website at [www.supermicro.com](http://www.supermicro.com) > Products. Find the product page for your motherboard, and "Download the Latest Drivers and Utilities".

Insert the flash dor media drive and the screenshot shown below should appear.



**Figure 5-3. Driver and Tool Installation Screen**

**Note:** Click the icons showing a hand writing on paper to view the readme files for each item. Click the computer icons to the right of these items to install each item (from top to the bottom) one at a time. **After installing each item, you must re-boot the system before moving on to the next item on the list.** The bottom icon with a CD on it allows you to view the entire contents.

## 5.3 SuperDoctor® 5

The Supermicro SuperDoctor 5 is a program that functions in a command-line or web-based interface for Windows and Linux operating systems. The program monitors such system health information as CPU temperature, system voltages, system power consumption, fan speed, and provides alerts via email or Simple Network Management Protocol (SNMP).

SuperDoctor 5 comes in local and remote management versions and can be used with Nagios to maximize your system monitoring needs. With SuperDoctor 5 Management Server (SSM Server), you can remotely control power on/off and reset chassis intrusion for multiple systems with SuperDoctor 5 or BMC. SuperDoctor 5 Management Server monitors HTTP, FTP, and SMTP services to optimize the efficiency of your operation.

[SuperDoctor® Manual and Resources](#)

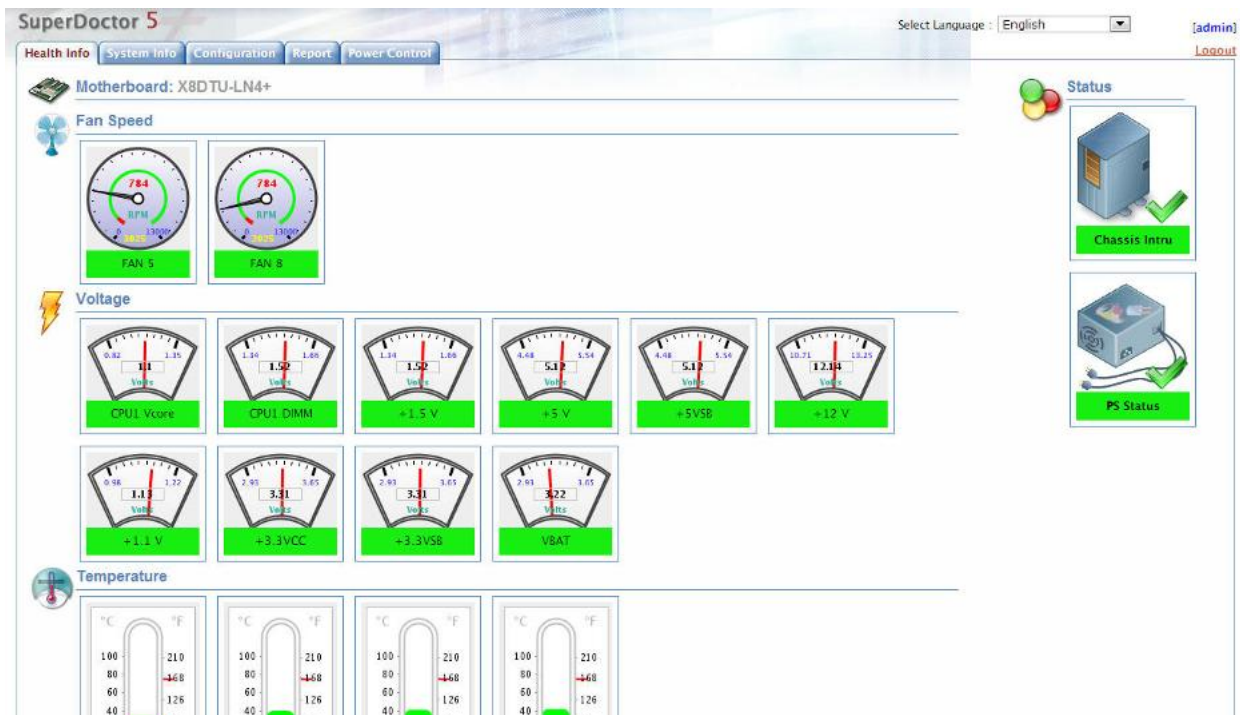


Figure 5-4. SuperDoctor 5 Interface Display Screen (Health Information)

## 5.4 BMC

The motherboard provides remote access, monitoring and management through the baseboard management controller (BMC) and other management controllers distributed among different system modules. There are several BIOS settings that are related to BMC. For general documentation and information on BMC, visit our website at: [www.supermicro.com/en/solutions/management-software/bmc-resources](http://www.supermicro.com/en/solutions/management-software/bmc-resources).

### BMC ADMIN User Password

For security, each system is assigned a unique default BMC password for the ADMIN user. This can be found on a sticker on the chassis and a sticker on the motherboard. The sticker also displays the BMC MAC address.



Figure 5-5. BMC Password Label

## Chapter 6

# Optional Components

This chapter describes optional system components and installation procedures.

Optional Parts List	
Description	Part Number
Network card	AOC-S25G-M2S
	AOC-SGP-I2
	AOC-S40G-I2Q
Power cord	CBL-PWCD-0579-1
	CBL-PWCD-0300-IS
	CBL-PWCD-0579
NVMe kit (up to two NVMe drive support)	CBL-PWEX-1136-40
	MCP-240-00207-0N
	CBL-MCIO-1232M5
NVMe kit (up to four NVMe drive support)	CBL-MCIO-1232M5
	CBL-PWEX-1136-70
	CBL-PWEX-1136-40
	MCP-240-00206-0N
	MCP-240-00207-0N
	AOM-TPM-9671V-S-O
<a href="#">TPM security module</a>	AOM-TPM-9670V-S-O

### 6.1 Additional Storage Drives

The system supports 24 hot-swap 3.5" SATA3/SAS3 drives, accessible from the chassis front.

### 6.2 Storage Control Card and Cable(s)

Supermicro offers storage controller cards for various data protection and drive RAID levels. Please refer to the product page for the latest cards and add-on options.

## 6.3 TPM Security Module

SPI capable TPM 2.0 (or 1.2) with Infineon 9670 controller, horizontal form factor

The JTPM1 header is used to connect a Trusted Platform Module (TPM). A TPM is a security device that supports encryption and authentication in drives. It enables the motherboard to deny access if the TPM associated with the drive is not installed in the system.

Details and installation procedures are at:

<http://www.supermicro.com/manuals/other/TPM.pdf>.

- AOM-TPM-9671V-S-O
- AOM-TPM-9670V-S-O

## 6.4 Intel Virtual RAID on CPU (VROC)

Intel® Virtual RAID on CPU (Intel VROC) is an enterprise RAID solution for NVMe SSDs directly attached to Intel Xeon Scalable processors. Intel Volume Management Device (VMD) is an integrated controller inside the CPU PCIe root complex.

- A single processor supports up to 12 NVMe SSDs and up to 6 RAID arrays.
- A dual processor system supports up to 24 NVMe SSDs and 12 RAID arrays.

Stripe sizes are 4K, 8K, 16K, 32K, 64K, 128K.

### Requirements and Restrictions

- **Intel VROC is only available when the system is configured for UEFI boot mode.**
- To enable the **mdadm** command and support for RSTe, install the patch from
  - Linux: <https://downloadcenter.intel.com/download/28158/Intel-Virtual-RAID-on-CPU-Intel-VROC-and-Intel-Rapid-Storage-Technology-enterprise-Intel-RSTe-Driver-for-Linux->
  - Windows: <https://downloadcenter.intel.com/download/28108/Intel-Virtual-RAID-on-CPU-Intel-VROC-and-Intel-Rapid-Storage-Technology-enterprise-Intel-RSTe-Driver-for-Windows->
- To enable Intel VROC, a hardware key must be inserted on the motherboard, and the appropriate processor's Virtual Management Devices must be enabled in the BIOS setup.
- It is possible to enable Intel VROC without a hardware key installed, but only RAID0 will be enabled.
- Intel VROC is not compatible with secure boot. This feature must be disabled.
- When creating bootable OS RAID1 devices, you must have both devices on the same CPU, and a VMD on that CPU.
- Spanning drives when creating RAID devices is not recommended to due to performance issues, even though it is supported.

### Supported SSDs and Operating Systems

To see the latest support information: <https://www.intel.com/content/www/us/en/support/articles/000030310/memory-and-storage/ssd-software.html>

## Additional Information

Additional information is available on the product page for the Supermicro add-on card and the linked manuals.

[www.supermicro.com/products/accessories/addon/AOC-VROCxxxMOD.cfm](http://www.supermicro.com/products/accessories/addon/AOC-VROCxxxMOD.cfm)

## Hardware Key

The Intel VROC hardware key is a license key that detects the Intel VROC SKU and activates the function accordingly. The key must be plugged into the Supermicro motherboard (connector JRK1). The key options are:

Intel® VROC Keys			
VROC Package	Description	Part Number	Intel MM Number
Standard	RAID 0, 1, 10 Supports 3rd party SSDs	AOC-VROCSTNMOD	951605
Premium	RAID 0, 1, 5, 10 Supports 3rd party SSDs	AOC-VROCPREMOD	951606
Intel SSD only	RAID 0, 1, 5, 10 Supports Intel SSDs only	AOC-VROCINTMOD	956822

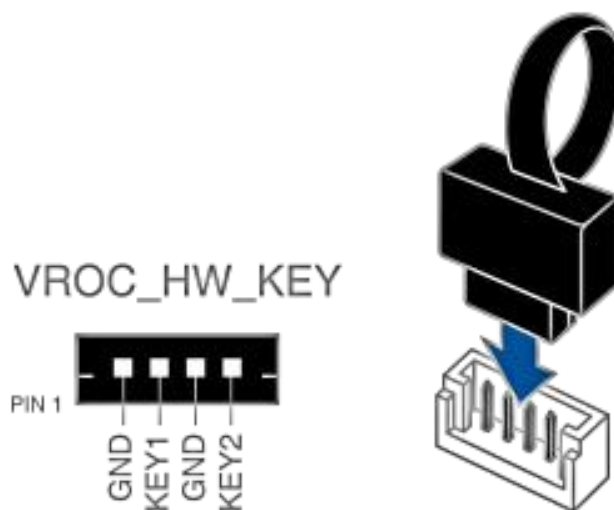
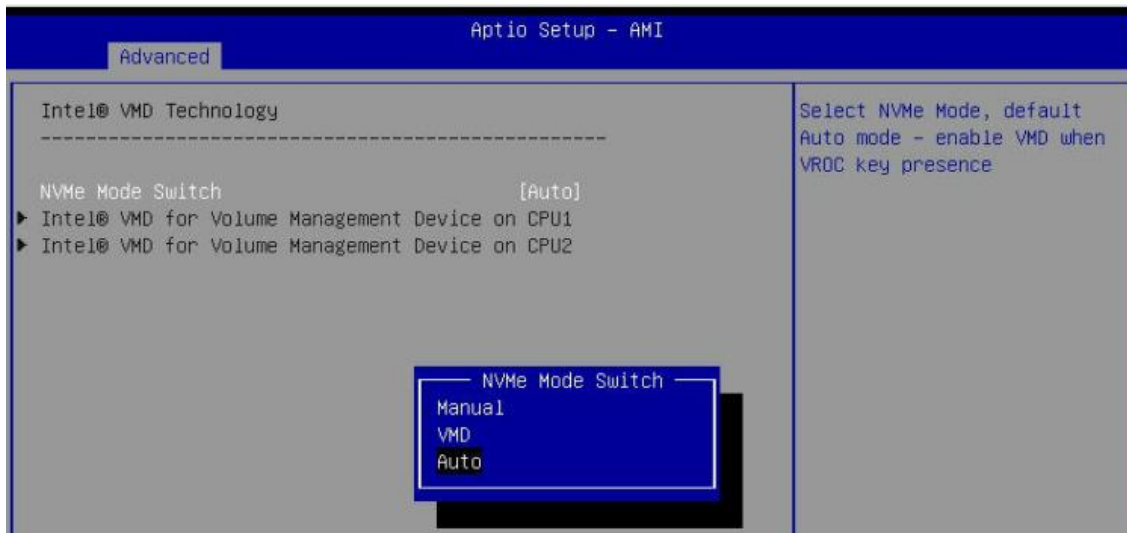


Figure 6-1. Intel VROC RAID Key and Motherboard Connector JRK1

## Configuring NVMe RAID Manually

RAID for NVMe SSDs is enabled by default when Intel VROC Raid Key is populated. It may be managed manually through the UEFI BIOS.

1. Reboot the server and press [DEL] key to access the BIOS options.
2. Switch to **Advanced > Chipset Configuration > North Bridge > IIO Configuration > Intel® VMD Technology**.

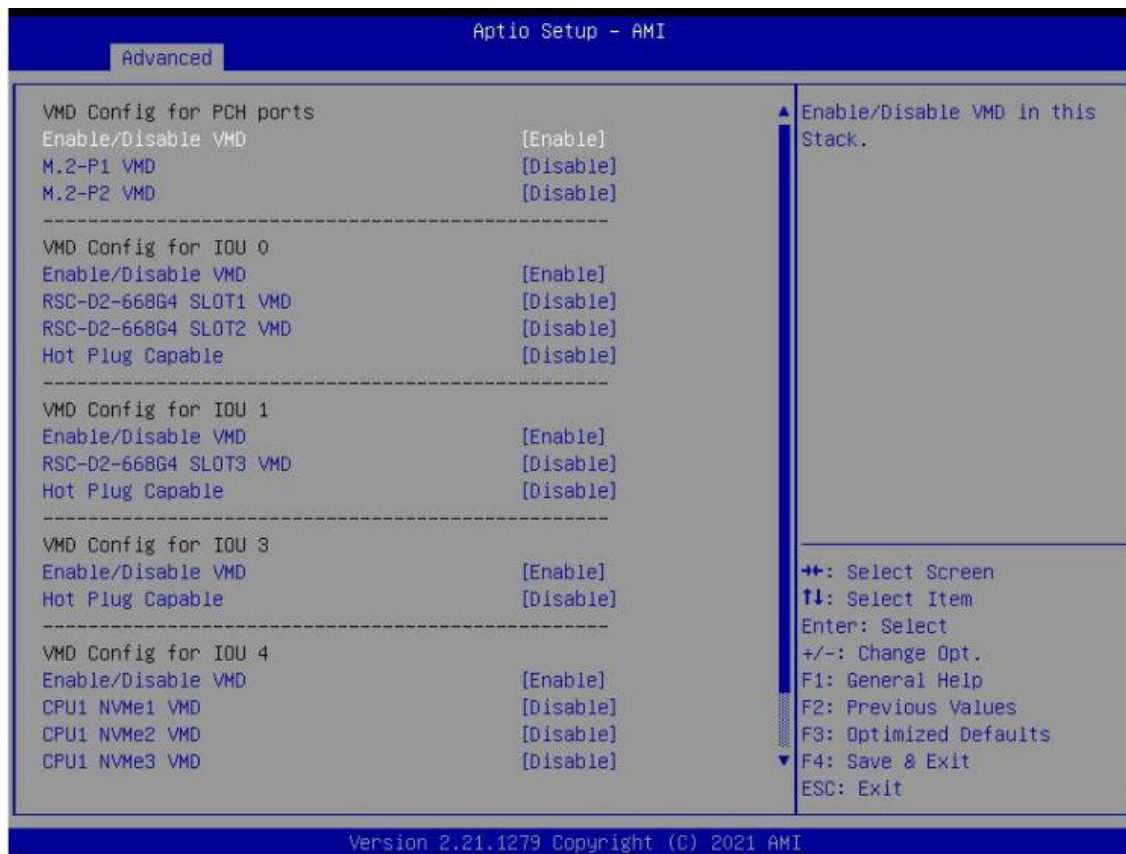


**Figure 6-2. BIOS, Selecting VMD Mode**

You can select a mode. The default is **Auto**. The **VMD** switch enables VMD mode for all NVMe ports despite the presence of the VROC key. The **Manual** switch allows the user to choose devices on which to enable VMD.

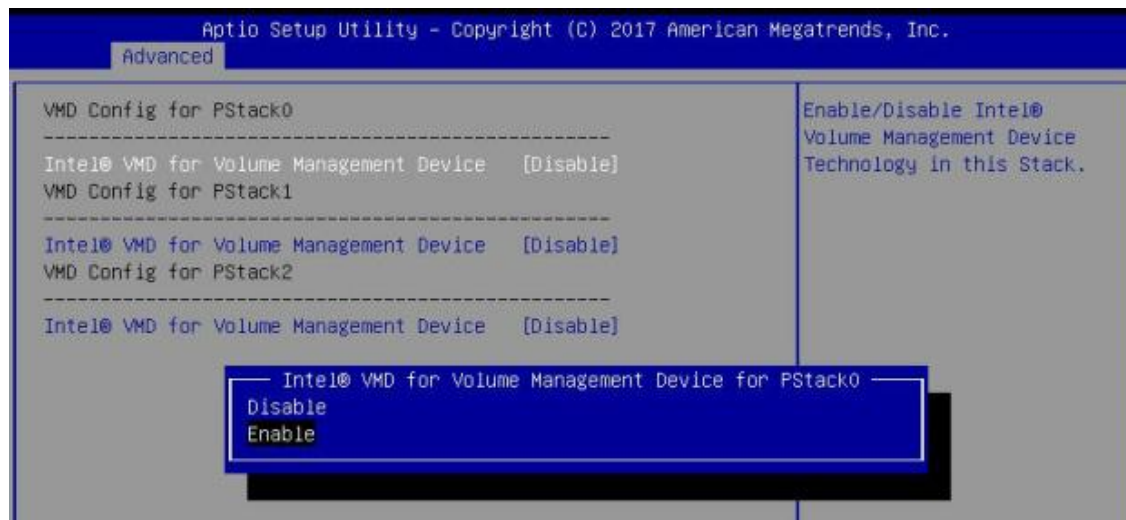
The onboard M.2 NVMe from PCH is located in the CPU1 section.

The screenshot below show example choices in Manual mode.



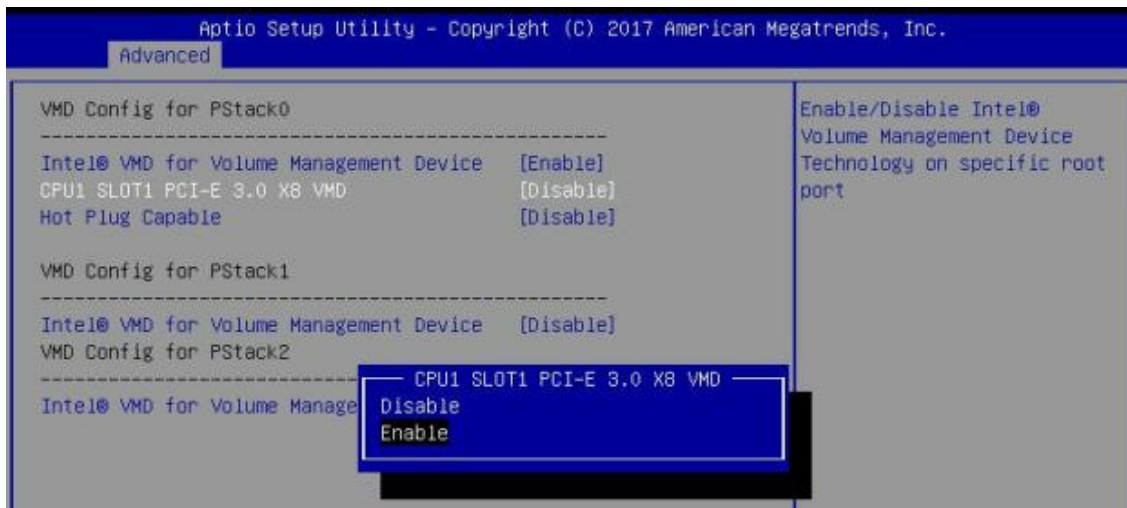
**Figure 6-3. BIOS, Manual Mode** (Example—your server may look different.)

3. Select the desired PStack# to Enable or Disable the corresponding Intel VMD controller



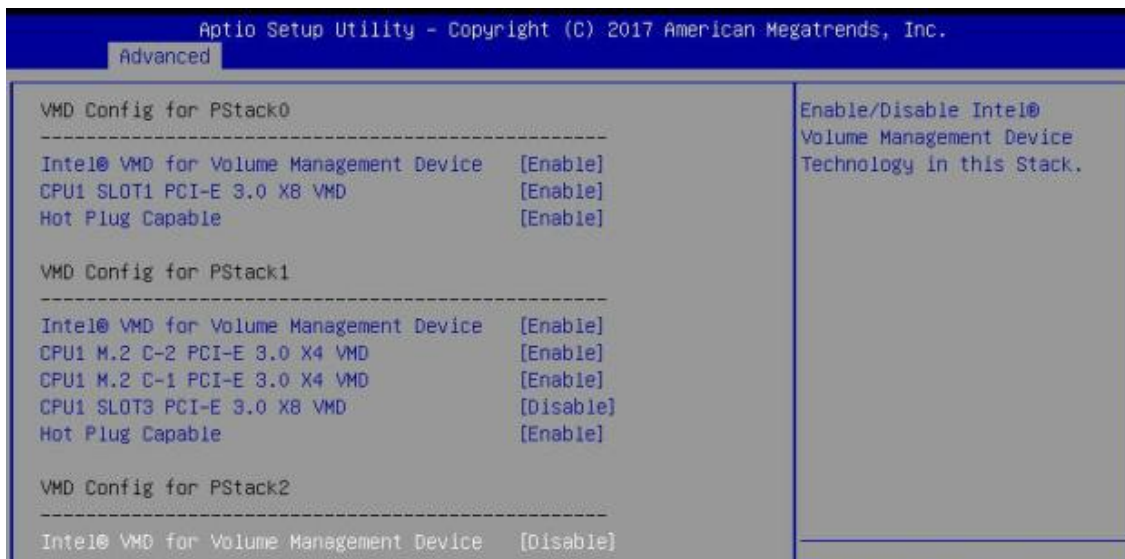
**Figure 6-4. BIOS, Enabling VMD for Pstack0**

4. Select the desired PCIe slot to Enable or Disable Intel VMD functionality according to the current hardware configuration being used. Hot Plug Capability can also be Enabled or Disabled.



**Figure 6-5. BIOS, Enabling VMD Functionality per Slot**

5. Repeat steps 3 and 4 for each PStack# on each CPU to be enabled or disabled. In this example, we enabled CPU1 Slot1 (Figure 6-11) and CPU2 Slot5 (Figure 6-12) (four U.2 form factor SSDs), as well as CPU1 M.2 C-1 and CPU1 M2. C-2 (two M.2 form factor SSDs)



**Figure 6-6. BIOS, Enabling CPU1 Example**

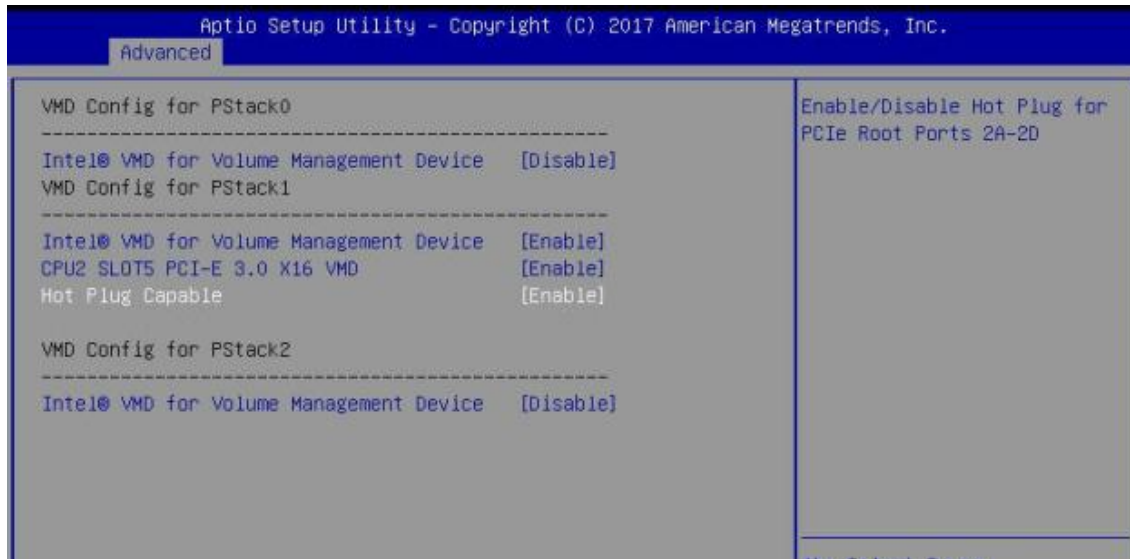


Figure 6-7. BIOS, Enabling CPU2 Example

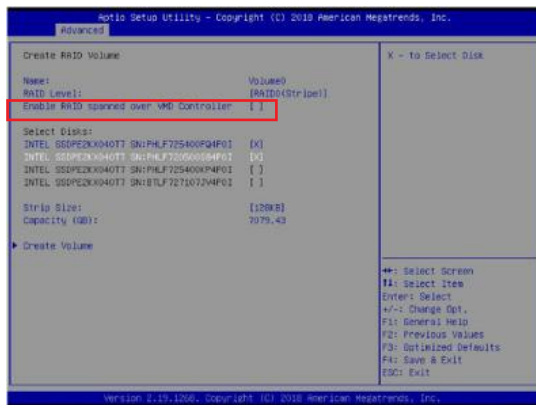
6. Press [F4] to save the configuration and reboot the system and press [DEL] to enter BIOS.

**Note:** Disabling the VMD controller without first deleting the associated existing RAID volume can lead to unexpected behavior. This action is strongly not recommended.

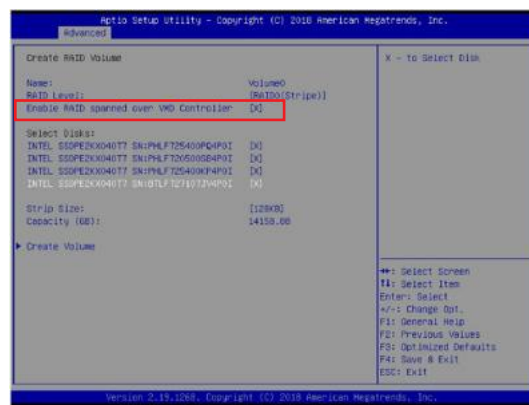
**Note:** The effects of physically changing or swapping a CPU on the VMD controller enablement has not yet been thoroughly tested or documented.

7. Switch to **Advanced > Intel(R) Virtual RAID on CPU > All Intel VMD Controllers > Create RAID Volume.**
8. Set **Name.**
9. Set **RAID Level.**

10. If cross-controller RAID is required, select **Enable RAID spanned over VMD Controller**.



**Figure 6-8. Created Volume *without* enabling RAID spanned over VMD controller**



**Figure 6-9. Created Volume *with* enabling RAID spanned over VMD controller**

11. Select specific disks for RAID with an [X].
- RAID0: Select at least two [2 - 24] disks
  - RAID1: Select only two disks
  - RAID5: Select at least three [3 - 24] disks
  - RAID10: Select only four disks
12. Select **Strip Size** (Default 64KB).
13. Select **Create Volume**.
14. If another RAID is needed, start again at step 9.
15. Press [F4] to save and reboot.

## Status Indications

An LED indicator on the drive carrier shows the RAID status of the drive.

Drive Carrier Status LED Indicator	
Status	State (red)
Normal function	Off
Locating	4 Hz blinking
Fault	Solid on
Rebuilding	1 Hz blinking

IBPI SFF 8489 Defined Status LED States

## Hot Swap Drives

Intel VMD enables hot-plug and hot-unplug for NVMe SSDs, whether from Intel or other manufacturers. Under vSphere ESXi, several steps are necessary to avoid potential stability issues. See the information at link [1] below.

### Hot-unplug

1. Prevent devices from being re-detected during rescan:

```
esxcli storage core claiming autoclaim --enabled=false
```

2. Unmount the VMFS volumes on the device. Check [2] for details.
3. Detach the device. Check [3] for details.
4. Physically remove the device.

### Hot-plug

- Physically install the device.

ESXi will automatically discover NVMe SSDs, but a manual scan may be required in some cases.

## Related Information Links

[1] <https://kb.vmware.com/s/article/2151404>

[2] <https://docs.vmware.com/en/VMware-vSphere/6.5/com.vmware.vsphere.storage.doc/GUID-1B56EF97-F60E-4F21-82A7-8F2A7294604D.html>

[3] <https://docs.vmware.com/en/VMware-vSphere/6.5/com.vmware.vsphere.storage.doc/GUID-F2E75F67-740B-4406-9F0C-A2D99A698F2A.html>

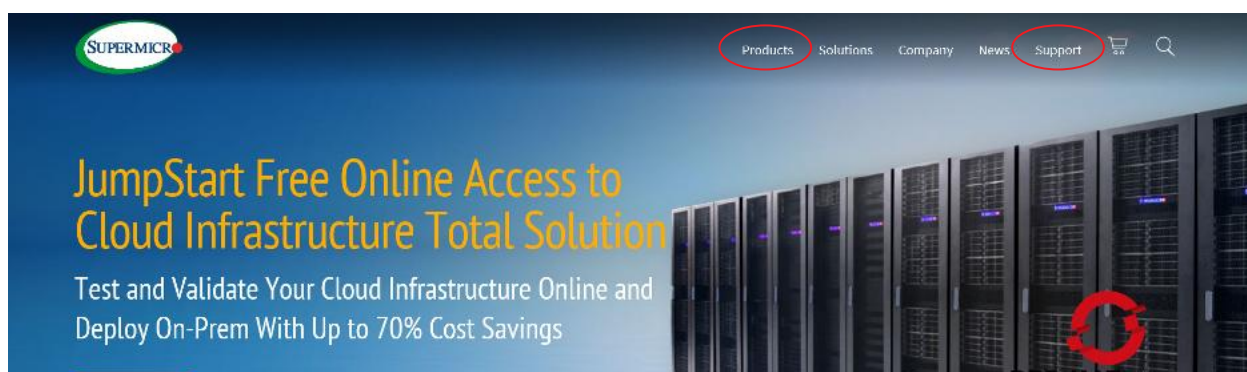
## Chapter 7

# Troubleshooting and Support

## 7.1 Information Resources

### Website

A great deal of information is available on the Supermicro website, [supermicro.com](http://supermicro.com).



**Figure 7-1. Supermicro Website**

- Specifications for servers and other hardware are available by clicking the **Products** option.
- The **Support** option offers downloads (manuals, BIOS/BMC, drivers, etc.), FAQs, RMA, warranty, and other service extensions.

### ***Direct Links for the ASG -2015S-E1CR24H/ASG -2015S-E1CR24L System***

Web [ASG -2015S-E1CR24H](#) and [ASG -2015S-E1CR24L](#) specifications page

[H13SSW](#) motherboard page for links to the Quick Reference Guide, User Manual, validated storage drives, etc.

### ***Direct Links for General Support and Information***

[Frequently Asked Questions](#)

[Add-on card descriptions](#)

[TPM User Guide](#)

General Memory Configuration Guide: [H13](#)

[SuperDoctor5 Large Deployment Guide](#)

For validated memory, use our [Product Resources page](#)

### ***Direct Links (continued)***

[Product Matrices](#) page for links to tables summarizing specs for systems, motherboards, power supplies, riser cards, add-on cards, etc.

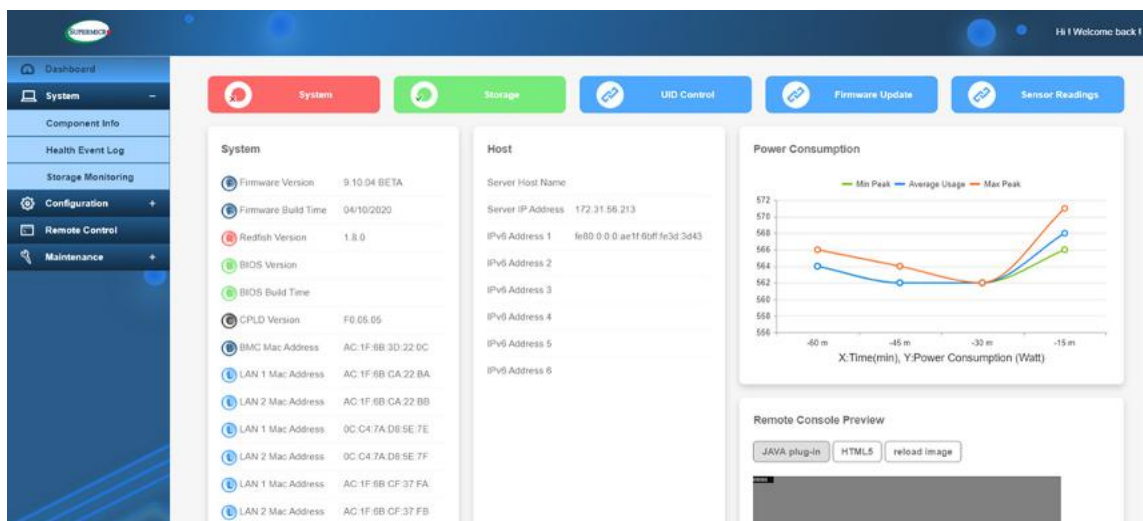
[Security Center](#) for recent security notices

[Supermicro Phone and Addresses](#)

## **7.2 Baseboard Management Controller (BMC)**

The system supports the Baseboard Management Controller (BMC). BMC is used to provide remote access, monitoring and management. There are several BIOS settings that are related to BMC.

For general documentation and information on BMC, please visit our website at: <https://www.supermicro.com/en/solutions/management-software/bmc-resources>.



**Figure 7-2. BMC Sample**

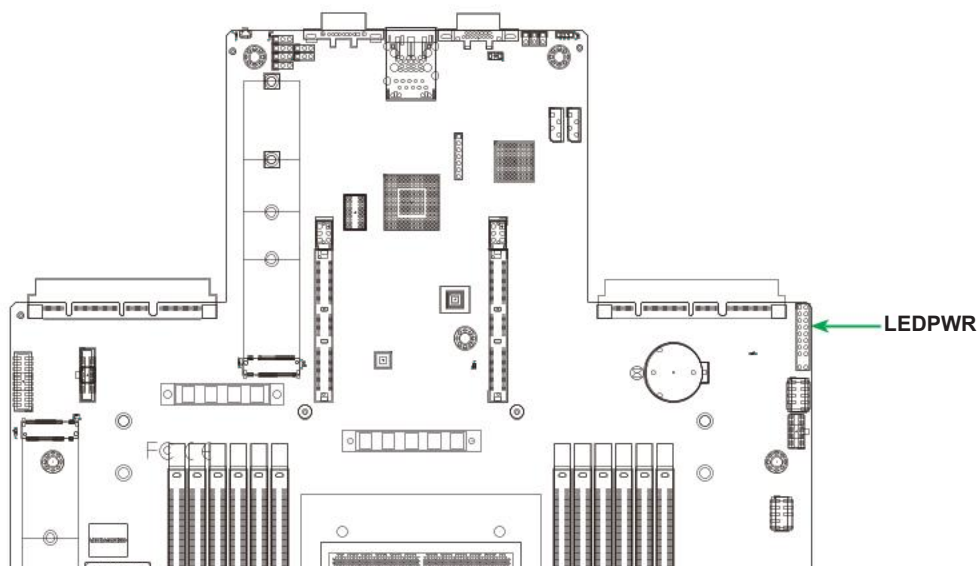
## 7.3 Troubleshooting Procedures

Use the following procedures to troubleshoot your system. If you have followed all of the procedures below and still need assistance, refer to the [Technical Support Procedures](#) or [Returning Merchandise for Service](#) sections in this chapter. [Power down](#) the system before changing any non hot-swap hardware components.

### General Technique

If you experience unstable operation or get no boot response, try:

1. With power off, remove all but one DIMM and other added components, such as add-on cards, from the motherboard. Make sure the motherboard is not shorted to the chassis.



**Figure 7-3. Location of the MB Power LED**

2. Set all jumpers to their default positions.
3. Power up. If the system boots, check for memory errors and add-on card problems.

### No Power to the System

- Check that the power LED on the motherboard is on.
- Make sure AC power is being supplied to the power supply.
- Check that the power cord is plugged into a power outlet that supply 100-127 Vac, 50-60 Hz, 12-15 A and 200-240 Vac, 50-60 Hz, 7-8.5 A.
- Turn the power switch on and off to test the system.

## No Video

1. If the power is on, but you have no video, remove all add-on cards and cables.
2. Use the speaker to determine if any beep codes are present. Refer to Appendix A for details on beep codes.
3. Remove all memory modules and turn on the system (if the alarm is on, check the specs of memory modules, reset the memory or try a different one).

## System Boot Failure

If the system does not display Power-On-Self-Test (POST) or does not respond after the power is turned on, check the following:

1. Check for any error beep from the motherboard speaker.
  - If there is no error beep, try to turn on the system without DIMM modules installed. If there is still no error beep, replace the motherboard.
  - If there are error beeps, clear the CMOS settings by unplugging the power cord and contacting both pads on the CMOS clear jumper (JBT1). Refer to Clear CMOS in Chapter 2.
2. Remove all components from the motherboard, especially the DIMM modules. Make sure that system power is on and that memory error beeps are activated.
3. Turn on the system with only one DIMM module installed. If the system boots, check for bad DIMM modules or slots by following the Memory Errors Troubleshooting procedure in this chapter.

## Memory Errors

1. Make sure that the DIMM modules are properly and fully installed.
2. Confirm that you are using the correct memory. Also, it is recommended that you use the same memory type and speed for all DIMMs in the system. See [Section 3.4](#) for memory details.
3. Check for bad DIMM modules or slots by swapping modules between slots and noting the results.
4. Check the power supply voltage 115 V/230 V switch.

## Losing the System Setup Configuration

1. Always replace power supplies with the exact same model that came with the system. A poor quality power supply may cause the system to lose the CMOS setup configuration.
2. The battery on your motherboard may be old. Check to verify that it still supplies approximately 3 VDC. If it does not, replace it with a new one.
3. If the above steps do not fix the setup configuration problem, contact your vendor for repairs.

## When the System Becomes Unstable

***If the system becomes unstable during or after OS installation, check the following:***

1. CPU/BIOS support: Make sure that your CPU is supported and that you have the latest BIOS installed in your system.
2. Memory support: Make sure that the memory modules are supported by testing the modules using memtest86 or a similar utility.

**Note:** Refer to the product page on our website at <http://www.supermicro.com> for memory and CPU support and updates.

3. Storage drive support: Make sure that all storage drives work properly. Replace the bad drives with good ones.
4. System cooling: Check the system cooling to make sure that all heatsink fans and CPU/system fans, etc., work properly. Check the hardware monitoring settings in the BMC to make sure that the CPU and system temperatures are within the normal range. Also check the front panel Overheat LED and make sure that it is not on.
5. Adequate power supply: Make sure that the power supply provides adequate power to the system. Make sure that all power connectors are connected. Please refer to our website for more information on the minimum power requirements.
6. Proper software support: Make sure that the correct drivers are used.

***If the system becomes unstable before or during OS installation, check the following:***

1. Source of installation: Make sure that the devices used for installation are working properly, including boot devices such as CD.
2. Cable connection: Check to make sure that all cables are connected and working properly.
3. Using the minimum configuration for troubleshooting: Remove all unnecessary components (starting with add-on cards first), and use the minimum configuration (but with a CPU and a

memory module installed) to identify the trouble areas. Refer to the steps listed in Section A above for proper troubleshooting procedures.

4. Identifying bad components by isolating them: If necessary, remove a component in question from the chassis, and test it in isolation to make sure that it works properly. Replace a bad component with a good one.
5. Check and change one component at a time instead of changing several items at the same time. This will help isolate and identify the problem.
6. To find out if a component is good, swap this component with a new one to see if the system will work properly. If so, then the old component is bad. You can also install the component in question in another system. If the new system works, the component is good and the old system has problems.

## 7.4 Crash Dump Using BMC

In the event of a processor internal error (IERR) that crashes your system, you may want to provide information to support staff. You can download a crash dump of status information using BMC.

### Check the BMC Error Log

1. Access the BMC web interface.
2. Click the **Server Health** tab, then **Event Log** to verify an IERR error.

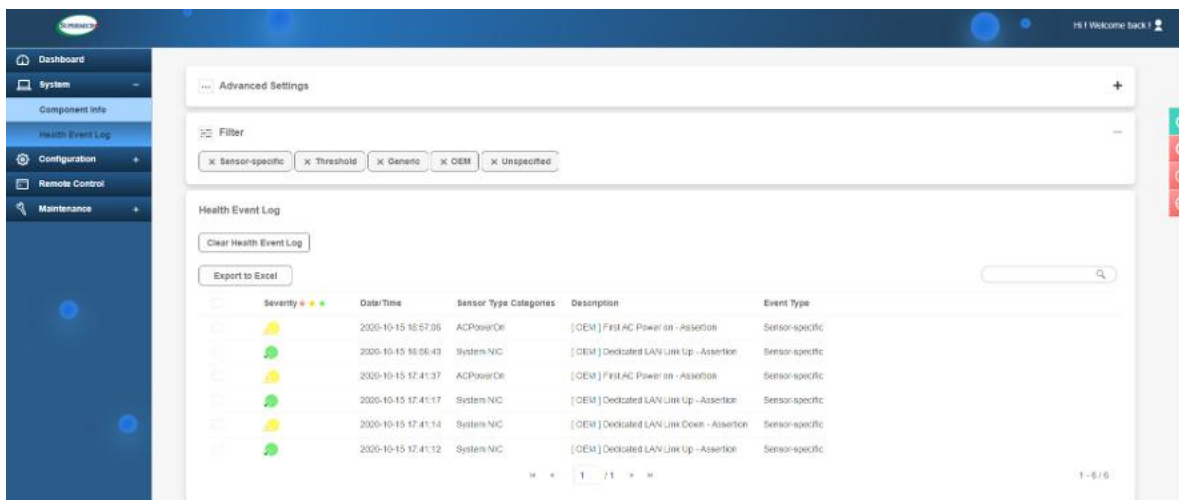


Figure 7-4. BMC Event Log

In the event of an IERR, the BMC executes a crash dump. You must download the crash dump and save it.

## 7.5 CMOS Clear

JBT1 is used to clear CMOS, which will also clear any passwords. Instead of pins, this jumper consists of contact pads to prevent accidentally clearing the contents of CMOS.

### To Clear CMOS

1. First [power down](#) the system completely.
2. [Remove the cover](#) of the chassis to access the motherboard.
3. [Remove the onboard battery](#) from the motherboard.
4. Short the CMOS pads with a metal object such as a small screwdriver for at least four seconds.
5. Remove the screwdriver or shorting device.
6. Replace the cover, reconnect the power cords and power on the system.



**Notes:** Clearing CMOS will also clear all passwords.

*Do not use the PW\_ON connector to clear CMOS.*

## 7.6 BMC Reset

The BMC can be reset using the UID button.

- Reset – Press and hold the button. After six seconds, the LED blinks at 2 Hz. The BMC resets and the reset duration is approximately 250 ms. Then the BMC starts to boot.
- Restore factory default configuration – Hold the button for twelve seconds. The LED blinks at 4 Hz while defaults are configured. **Note:** All BMC settings including username and password will be removed except the FRU and network settings.

Firmware update – When the BMC firmware is being updated, the UID LED blinks at 10 Hz.

BMC Reset Options		
Event	UID LED	BMC Heartbeat LED
Reset	Blue, Blinks at 2 Hz	Green, solid
Restore Defaults	Blue, Blinks at 4 Hz	Off
Update	Blue, Blinks at 10 Hz	

## 7.7 Where to Get Replacement Components

If you need replacement parts for your system, to ensure the highest level of professional service and technical support, purchase exclusively from our Supermicro Authorized Distributors/System Integrators/Resellers. A list can be found at: <http://www.supermicro.com>. Click the "Where to Buy" tab.

## 7.8 Reporting an Issue

### Technical Support Procedures

Before contacting Technical Support, please take the following steps. If your system was purchased through a distributor or reseller, please contact them for troubleshooting services. They have the best knowledge of your specific system configuration.

1. Please review the [Troubleshooting Procedures](#) in this manual and [Frequently Asked Questions](#) on our website before contacting Technical Support.
2. BIOS upgrades can be downloaded from our website. **Note:** Not all BIOS can be flashed depending on the modifications to the boot block code.
3. If you still cannot resolve the problem, include the following information when contacting us for technical support:
  - System, motherboard, and chassis model numbers and PCB revision number
  - BIOS release date/version (this can be seen on the initial display when your system first boots up)
  - System configuration

An example of a Technical Support form is posted on our [website](#). Distributors: For immediate assistance, please have your account number ready when contacting our technical support department by email.

### Returning Merchandise for Service

A receipt or copy of your invoice marked with the date of purchase is required before any warranty service will be rendered. You can obtain service by calling your vendor for a Returned Merchandise Authorization (RMA) number. When returning to the manufacturer, the RMA number should be prominently displayed on the outside of the shipping carton, and mailed prepaid or hand-carried. Shipping and handling charges will be applied for all orders that must be mailed when service is complete.

For faster service, RMA authorizations may be requested online (<http://www.supermicro.com/support/rma/>).

Whenever possible, repack the chassis in the original Supermicro carton, using the original packaging material. If these are no longer available, be sure to pack the chassis securely, using packaging material to surround the chassis so that it does not shift within the carton and become damaged during shipping.

This warranty only covers normal consumer use and does not cover damages incurred in shipping or from failure due to the alteration, misuse, abuse or improper maintenance of products.

During the warranty period, contact your distributor first for any product problems.

### **Vendor Support Filing System**

For issues related to Intel, use the Intel IPS filing system:

<https://www.intel.com/content/www/us/en/design/support/ips/training/welcome.html>

For issues related to Red Hat Enterprise Linux, since it is a subscription based OS, contact your account representative.

## **7.9 Feedback**

Supermicro values your feedback as we strive to improve our customer experience in all facets of our business. Please email us at [techwriterteam@supermicro.com](mailto:techwriterteam@supermicro.com) to provide feedback on our manuals.

## Appendix A

# Standardized Warning Statements for AC Systems

### About Standardized Warning Statements

The following statements are industry standard warnings, provided to warn the user of situations which have the potential for bodily injury. Should you have questions or experience difficulty, contact Supermicro's Technical Support department for assistance. Only certified technicians should attempt to install or configure components.

Read this appendix in its entirety before installing or configuring components in the Supermicro chassis.

These warnings may also be found on our website at [http://www.supermicro.com/about/policies/safety\\_information.cfm](http://www.supermicro.com/about/policies/safety_information.cfm).

### Warning Definition



**Warning!** This warning symbol means danger. You are in a situation that could cause bodily injury. Before you work on any equipment, be aware of the hazards involved with electrical circuitry and be familiar with standard practices for preventing accidents.

#### 警告の定義

この警告サインは危険を意味します。

人身事故につながる可能性がありますので、いずれの機器でも動作させる前に、電気回路に含まれる危険性に注意して、標準的な事故防止策に精通して下さい。

此警告符号代表危險。

您正处于可能受到严重伤害的工作环境中。在您使用设备开始工作之前，必须充分意识到触电的危险，并熟练掌握防止事故发生的标准工作程序。请根据每项警告结尾的声明号码找到此设备的安全性警告说明的翻译文本。

此警告符號代表危險。

您正處於可能身體可能會受損傷的工作環境中。在您使用任何設備之前，請注意觸電的危險，並且要熟悉預防事故發生的標準工作程序。請依照每一注意事項後的號碼找到相關的翻譯說明內容。

## Warnung

### WICHTIGE SICHERHEITSHINWEISE

Dieses Warnsymbol bedeutet Gefahr. Sie befinden sich in einer Situation, die zu Verletzungen führen kann. Machen Sie sich vor der Arbeit mit Geräten mit den Gefahren elektrischer Schaltungen und den üblichen Verfahren zur Vorbeugung vor Unfällen vertraut. Suchen Sie mit der am Ende jeder Warnung angegebenen Anweisungsnummer nach der jeweiligen Übersetzung in den übersetzten Sicherheitshinweisen, die zusammen mit diesem Gerät ausgeliefert wurden.

BEWAHREN SIE DIESE HINWEISE GUT AUF.

### INSTRUCCIONES IMPORTANTES DE SEGURIDAD

Este símbolo de aviso indica peligro. Existe riesgo para su integridad física. Antes de manipular cualquier equipo, considere los riesgos de la corriente eléctrica y familiarícese con los procedimientos estándar de prevención de accidentes. Al final de cada advertencia encontrará el número que le ayudará a encontrar el texto traducido en el apartado de traducciones que acompaña a este dispositivo.

GUARDE ESTAS INSTRUCCIONES.

### IMPORTANTES INFORMATIONS DE SÉCURITÉ

Ce symbole d'avertissement indique un danger. Vous vous trouvez dans une situation pouvant entraîner des blessures ou des dommages corporels. Avant de travailler sur un équipement, soyez conscient des dangers liés aux circuits électriques et familiarisez-vous avec les procédures couramment utilisées pour éviter les accidents. Pour prendre connaissance des traductions des avertissements figurant dans les consignes de sécurité traduites qui accompagnent cet appareil, référez-vous au numéro de l'instruction situé à la fin de chaque avertissement.

CONSERVEZ CES INFORMATIONS.

## תקנון הזהרות אזהרה

הזהרות הבאות הן אזהרות על פי תקני התעשייה, על מנת להזהיר את המשתמש מפני חבלה פיזית אפשרית. במידה ויש שאלות או היתקלות בבעיה כלשהי, יש ליצור קשר עם מחלקת תמיכה טכנית של סופרמיקרו. טכנאים מוסמכים בלבד רשאים להתקין או להגדיר את הרכיבים. יש לקרוא את הנספח במלואו לפני התקנת או הגדרת הרכיבים במארזי סופרמיקרו.

اَكْ ف حالة وُكِي اَي تتسبب ف اصابة جسدهُ هذا الزهز عْ خطر! تحذُرُ .  
 قبل اَي تعول على اَي هعدات، كي على علن بالوخاطز ال اَجوة عي الذوائر  
 الكهزبائِة  
 وكي على دراةُ بالووارسات النقااِة لو عْ وقع اَي حادث  
 استخدم رقن الب اِى الو صُص ف هَّاةُ كل تحذُرُ للعشر تزجوتها

안전을 위한 주의사항

경고!

이 경고 기호는 위험이 있음을 알려 줍니다. 작업자의 신체에 부상을 야기 할 수 있는 상태에 있게 됩니다. 모든 장비에 대한 작업을 수행하기 전에 전기회로와 관련된 위험요소들을 확인하시고 사전에 사고를 방지할 수 있도록 표준 작업절차를 준수해 주시기 바랍니다.

해당 번역문을 찾기 위해 각 경고의 마지막 부분에 제공된 경고문 번호를 참조하십시오

## BELANGRIJKE VEILIGHEIDSINSTRUCTIES

Dit waarschuwings symbool betekent gevaar. U verkeert in een situatie die lichamelijk letsel kan veroorzaken. Voordat u aan enige apparatuur gaat werken, dient u zich bewust te zijn van de bij een elektrische installatie betrokken risico's en dient u op de hoogte te zijn van de standaard procedures om ongelukken te voorkomen. Gebruik de nummers aan het eind van elke waarschuwing om deze te herleiden naar de desbetreffende locatie.

BEWAAR DEZE INSTRUCTIES

## Installation Instructions



**Warning!** Read the installation instructions before connecting the system to the power source.

設置手順書

システムを電源に接続する前に、設置手順書をお読み下さい。

警告

将此系统连接电源前,请先阅读安装说明。

警告

將系統與電源連接前，請先閱讀安裝說明。

**Warnung**

Vor dem Anschließen des Systems an die Stromquelle die Installationsanweisungen lesen.

**¡Advertencia!**

Lea las instrucciones de instalación antes de conectar el sistema a la red de alimentación.

**Attention**

Avant de brancher le système sur la source d'alimentation, consulter les directives d'installation.

יש לקרוא את הוראות התקנה לפני חיבור המערכת למקור מתח.

اقرأ إرشادات التركيب قبل توصيل النظام إلى مصدر للطاقة

시스템을 전원에 연결하기 전에 설치 안내를 읽어주십시오.

**Waarschuwing**

Raadpleeg de installatie-instructies voordat u het systeem op de voedingsbron aansluit.

**Circuit Breaker**

**Warning!** This product relies on the building's installation for short-circuit (overcurrent) protection. Ensure that the protective device is rated not greater than: 250 V, 20 A.

**サーキット・ブレーカー**

この製品は、短絡(過電流)保護装置がある建物での設置を前提としています。

保護装置の定格が250 V、20 Aを超えないことを確認下さい。

**警告**

此产品的短路(过载电流)保护由建筑物的供电系统提供,确保短路保护设备的额定电流不大于250V,20A。

**警告**

此產品的短路(過載電流)保護由建築物的供電系統提供,確保短路保護設備的額定電流不大於250V,20A。

**Warnung**

Dieses Produkt ist darauf angewiesen, dass im Gebäude ein Kurzschluss- bzw. Überstromschutz installiert ist. Stellen Sie sicher, dass der Nennwert der Schutzvorrichtung nicht mehr als: 250 V, 20 A beträgt.

**¡Advertencia!**

Este equipo utiliza el sistema de protección contra cortocircuitos (o sobrecorrientes) del edificio. Asegúrese de que el dispositivo de protección no sea superior a: 250 V, 20 A.

**Attention**

Pour ce qui est de la protection contre les courts-circuits (surtension), ce produit dépend de l'installation électrique du local. Vérifiez que le courant nominal du dispositif de protection n'est pas supérieur à :250 V, 20 A.

מוצר זה מסתמך על הגנה המותקנת במבנים למניעת קצר חשמלי. יש לוודא כי המכשיר המגן מפני הקצר החשמלי הוא לא יותר מ-250VDC, 20A

هذا المنتج يعتمد على معدات الحماية مه الدوائر القصيرة التي تم تثبيتها في المبنى  
تأكد من أن تقييم الجهاز الوقائي ليس أكثر من : 20A, 250V

**경고!**

이 제품은 전원의 단락(과전류)방지에 대해서 전적으로 건물의 관련 설비에 의존합니다. 보호장치의 정격이 반드시 250V(볼트), 20A(암페어)를 초과하지 않도록 해야 합니다.

**Waarschuwing**

Dit product is afhankelijk van de kortsluitbeveiliging (overspanning) van uw elektrische installatie. Controleer of het beveiligde apparaat niet groter gedimensioneerd is dan 250V, 20A.

## Power Disconnection Warning



**Warning!** The system must be disconnected from all sources of power and the power cord removed from the power supply module(s) before accessing the chassis interior to install or remove system components (except for hot-swap components).



### 電源切断の警告

システムコンポーネントの取り付けまたは取り外しのために、シャーシ内部にアクセスするには、システムの電源はすべてのソースから切断され、電源コードは電源モジュールから取り外す必要があります。

### 警告

在你打开机箱并安装或移除内部器件前,必须将系统完全断电,并移除电源线。

### 警告

在您打開機殼安裝或移除內部元件前，必須將系統完全斷電，並移除電源線。

### Warnung

Das System muss von allen Quellen der Energie und vom Netzanschlusskabel getrennt sein, das von den Spg.Versorgungsteilmodulen entfernt wird, bevor es auf den Chassisinnenraum zurückgreift, um Systemsbestandteile anzubringen oder zu entfernen.

### ¡Advertencia!

El sistema debe ser disconnected de todas las fuentes de energía y del cable eléctrico quitado de los módulos de fuente de alimentación antes de tener acceso el interior del chasis para instalar o para quitar componentes de sistema.

### Attention

Le système doit être débranché de toutes les sources de puissance ainsi que de son cordon d'alimentation secteur avant d'accéder à l'intérieur du chassis pour installer ou enlever des composants de système.

אזהרה מפני ניתוק חשמלי

אזהרה!

יש לנתק את המערכת מכל מקורות החשמל ויש להסיר את כבל החשמלי מהספק לפני גישה לחלק הפנימי של המארז לצורך התקנת או הסרת רכיבים.

يجب فصل انظاؤ من جميع مصادر انطاقت وإزانت سهك انكهرباء من وحدة امداد انطاقت قيم

انصل إلى امناطق انداخييت نههيكم نشييج أو إزانت مكنناث الجهاز

경고!

시스템에 부품들을 장착하거나 제거하기 위해서는 새시 내부에 접근하기 전에 반드시 전원 공급장치로부터 연결되어있는 모든 전원과 전기코드를 분리해주어야 합니다.

Waarschuwing

Voordat u toegang neemt tot het binnenwerk van de behuizing voor het installeren of verwijderen van systeem onderdelen, dient u alle spanningsbronnen en alle stroomkabels aangesloten op de voeding(en) van de behuizing te verwijderen

## Equipment Installation



**Warning!** Only authorized personnel and qualified service persons should be allowed to install, replace, or service this equipment.

機器の設置

トレーニングを受け認定された人だけがこの装置の設置、交換、またはサービスを許可されています。

警告

只有经过培训且具有资格的人员才能进行此设备的安装、更换和维修。

警告

只有經過受訓且具資格人員才可安裝、更換與維修此設備。

Warnung

Nur autorisiertes Personal und qualifizierte Servicetechniker dürfen dieses Gerät installieren, austauschen oder warten..

¡Advertencia!

Sólo el personal autorizado y el personal de servicio calificado deben poder instalar, reemplazar o dar servicio a este equipo.

**Attention**

Seul le personnel autorisé et le personnel de maintenance qualifié doivent être autorisés à installer, remplacer ou entretenir cet équipement..

אזהרה!

יש לאפשר רק צוות מורשה ואנשי שירות מוסמכים להתקין, להחליף או לטפל בציוד זה.

ينبغي السماح فقط للموظفين المعتمدين وأفراد الخدمة المؤهلين بتركيب هذا الجهاز أو استبداله أو صيانته.

**경고!**

승인된 직원과 자격을 갖춘 서비스 담당자만이 이 장비를 설치, 교체 또는 서비스할 수 있습니다.

**Waarschuwing**

Alleen geautoriseerd personeel en gekwalificeerd onderhoudspersoneel mag deze apparatuur installeren, vervangen of onderhouden..

**Restricted Area**

**Warning!** This unit is intended for installation in restricted access areas. A restricted access area can be accessed only through the use of a special tool, lock and key, or other means of security. (This warning does not apply to workstations).

**アクセス制限区域**

このユニットは、アクセス制限区域に設置されることを想定しています。

アクセス制限区域は、特別なツール、鍵と錠前、その他のセキュリティの手段を用いてのみ出入りが可能です。

**警告**

此部件应安装在限制进出的场所，限制进出的场所指只能通过使用特殊工具、锁和钥匙或其它安全手段进出的场所。

**警告**

此裝置僅限安裝於進出管制區域，進出管制區域係指僅能以特殊工具、鎖頭及鑰匙或其他安全方式才能進入的區域。

**Warnung**

Diese Einheit ist zur Installation in Bereichen mit beschränktem Zutritt vorgesehen. Der Zutritt zu derartigen Bereichen ist nur mit einem Spezialwerkzeug, Schloss und Schlüssel oder einer sonstigen Sicherheitsvorkehrung möglich.

**¡Advertencia!**

Esta unidad ha sido diseñada para instalación en áreas de acceso restringido. Sólo puede obtenerse acceso a una de estas áreas mediante la utilización de una herramienta especial, cerradura con llave u otro medio de seguridad.

**Attention**

Cet appareil doit être installée dans des zones d'accès réservés. L'accès à une zone d'accès réservé n'est possible qu'en utilisant un outil spécial, un mécanisme de verrouillage et une clé, ou tout autre moyen de sécurité.

אזור עם גישה מוגבלת

אזהרה!

יש להתקין את היחידה באזורים שיש בהם הגבלת גישה. הגישה ניתנת בעזרת 'מפתח, מנעול וכד' (כלי אבטחה בלבד).

تخصيص هذه انحدة نترك بُها ف مناطق محظورة تم .

،ممكن اننصل إن منطقت محظورة فقط من خلال استخذاو أداة خاصت أو أ وس هُت أخري نلالأمما ققم ومفتاح

**경고!**

이 장치는 접근이 제한된 구역에 설치하도록 되어있습니다. 특수도구, 잠금 장치 및 키, 또는 기타 보안 수단을 통해서만 접근 제한 구역에 들어갈 수 있습니다.

**Waarschuwing**

Dit apparaat is bedoeld voor installatie in gebieden met een beperkte toegang. Toegang tot dergelijke gebieden kunnen alleen verkregen worden door gebruik te maken van speciaal gereedschap, slot en sleutel of andere veiligheidsmaatregelen.

## Battery Handling



**CAUTION:** There is risk of explosion if the battery is replaced by an incorrect type. Replace the battery only with the same or equivalent type recommended by the manufacturer. Dispose of used batteries according to the manufacturer's instructions

### 電池の取り扱い

バッテリーを間違ったタイプに交換すると爆発の危険があります。交換する電池はメーカーが推奨する型、または同等のものを使用下さい。使用済電池は製造元の指示に従って処分して下さい。

### 警告

如果更换的电池类型不正确，则存在爆炸危险。请只使用同类电池或制造商推荐的功能相当的电池更换原有电池。请按制造商的说明处理废旧电池。

### 警告

如果更換的電池類型不正確，則有爆炸危險。請使用製造商建議之相同或功能相當的電池更換原有電池。請按照製造商的說明指示處理廢棄舊電池。

### WARNUNG

Es besteht Explosionsgefahr, wenn die Batterie durch einen falschen Typ ersetzt wird. Ersetzen Sie die Batterie nur durch den gleichen oder vom Hersteller empfohlenen Batterietyp. Entsorgen Sie die benutzten Batterien nach den Anweisungen des Herstellers.

### ATTENTION

Il existe un risque d'explosion si la batterie est remplacée par un type incorrect. Ne la remplacer que par une pile de type semblable ou équivalent, recommandée par le fabricant. Jeter les piles usagées conformément aux instructions du fabricant.

### ADVERTENCIA

Existe riesgo de explosión si la batería se reemplaza por un tipo incorrecto. Reemplazar la batería exclusivamente con el mismo tipo o el equivalente recomendado por el fabricante. Desechar las baterías gastadas según las instrucciones del fabricante.

אזהרה!

קיימת סכנת פיצוץ אם הסוללה תוחלף בסוג שגוי. יש להחליף את הסוללה בסוג התואם מחברת יצרן מומלצת. סילוק הסוללות המשומשות יש לבצע לפי הוראות היצרן.

هناك خطر الانفجار إذا تم استبدال البطارية بنوع غير صحيح.  
 اسحبذال البطارية  
 فقط بنفس النوع أو ما يعادلها مما أوصت به الشركة المصنعة  
 جخلص من البطاريات المسحمة وفقا لعمليات الشركة الصانعة

경고!

배터리를 잘못된 종류로 교체하면 폭발의 위험이 있습니다. 기존 배터리와 동일하거나 제조사에서 권장하는 동등한 종류의 배터리로만 교체해야 합니다. 제조사의 안내에 따라 사용된 배터리를 처리하여 주십시오.

#### WAARSCHUWING

Er bestaat explosiegevaar als de batterij wordt vervangen door een verkeerd type. Vervang de batterij slechts met hetzelfde of een equivalent type die door de fabrikant aanbevolen wordt. Gebruikte batterijen dienen overeenkomstig fabrieksvoorschriften afgevoerd te worden.

### Redundant Power Supplies



**Warning!** This unit might have more than one power supply connection. All connections must be removed to de-energize the unit.

冗長電源装置

このユニットは複数の電源装置が接続されている場合があります。

ユニットの電源を切るためには、すべての接続を取り外さなければなりません。

警告

此部件连接的电源可能不止一个，必须将所有电源断开才能停止给该部件供电。

警告

此装置连接的电源可能不只一个，必须切断所有电源才能停止对该装置的供电。

Warnung

Dieses Gerät kann mehr als eine Stromzufuhr haben. Um sicherzustellen, dass der Einheit kein Strom zugeführt wird, müssen alle Verbindungen entfernt werden.

## ¡Advertencia!

Puede que esta unidad tenga más de una conexión para fuentes de alimentación. Para cortar por completo el suministro de energía, deben desconectarse todas las conexiones.

## Attention

Cette unité peut avoir plus d'une connexion d'alimentation. Pour supprimer toute tension et tout courant électrique de l'unité, toutes les connexions d'alimentation doivent être débranchées.

אם קיים יותר מספק אחד

אזהרה!

ליחידה יש יותר מחיבור אחד של ספק. יש להסיר את כל החיבורים על מנת לרוקן את היחידה.

قد يكون لهذا الجهاز عدة اتصالات بوحدات امداد الطاقة .

يجب إزالة كافة الاتصالات لعسل الوحدة عن الكهرباء

## 경고!

이 장치에는 한 개 이상의 전원 공급 단자가 연결되어 있을 수 있습니다. 이 장치에 전원을 차단하기 위해서는 모든 연결 단자를 제거해야만 합니다.

## Waarschuwing

Deze eenheid kan meer dan één stroomtoevoeraansluiting bevatten. Alle aansluitingen dienen verwijderd te worden om het apparaat stroomloos te maken.

## Backplane Voltage



**Warning!** Hazardous voltage or energy is present on the backplane when the system is operating. Use caution when servicing.

バックプレーンの電圧

システムの稼働中は危険な電圧または電力が、バックプレーン上にかかっています。

修理する際には注意ください。

警告

当系统正在进行时，背板上有很危险的电压或能量，进行维修时务必小心。

警告

當系統正在進行時，背板上有危險的電壓或能量，進行維修時務必小心。

Warnung

Wenn das System in Betrieb ist, treten auf der Rückwandplatine gefährliche Spannungen oder Energien auf. Vorsicht bei der Wartung.

¡Advertencia!

Cuando el sistema está en funcionamiento, el voltaje del plano trasero es peligroso. Tenga cuidado cuando lo revise.

Attention

Lorsque le système est en fonctionnement, des tensions électriques circulent sur le fond de panier. Prendre des précautions lors de la maintenance.

מתח בפנל האחורי

אזהרה!

קיימת סכנת מתח בפנל האחורי בזמן תפעול המערכת. יש להיזהר במהלך העבודה.

هناك خطر من التيار الكهربائي أو الطاقة المتجددة على اللوحة  
عندما يكون النظام يعمل كه حذرا عند خدمة هذا الجهاز

경고!

시스템이 동작 중일 때 후면판 (Backplane)에는 위험한 전압이나 에너지가 발생 합니다.  
서비스 작업 시 주의하십시오.

Waarschuwing

Een gevaarlijke spanning of energie is aanwezig op de backplane wanneer het systeem in gebruik is. Voorzichtigheid is geboden tijdens het onderhoud.

## Comply with Local and National Electrical Codes



**Warning!** Installation of the equipment must comply with local and national electrical codes.

地方および国の電気規格に準拠

機器の取り付けはその地方および国の電気規格に準拠する必要があります。

警告

设备安装必须符合本地与本国电气法规。

警告

設備安裝必須符合本地與本國電氣法規。

Warnung

Die Installation der Geräte muss den Sicherheitsstandards entsprechen.

¡Advertencia!

La instalación del equipo debe cumplir con las normas de electricidad locales y nacionales.

Attention

L'équipement doit être installé conformément aux normes électriques nationales et locales.

תיאום חוקי החשמל הארצי  
אזהרה!  
התקנת הציוד חייבת להיות תואמת לחוקי החשמל המקומיים והארציים.

تركيب المعدات الكهربائية يجب أن يمتثل للقوايه المحلية والبطية المتعلقة  
بالكهرباء

경고!

현 지역 및 국가의 전기 규정에 따라 장비를 설치해야 합니다.

Waarschuwing

Bij installatie van de apparatuur moet worden voldaan aan de lokale en nationale elektriciteitsvoorschriften.

## Product Disposal



**Warning!** Ultimate disposal of this product should be handled according to all national laws and regulations.

製品の廃棄

この製品を廃棄処分する場合、国の関係する全ての法律・条例に従い処理する必要があります。

警告

本产品的废弃处理应根据所有国家的法律和规章进行。

警告

本產品的廢棄處理應根據所有國家的法律和規章進行。

Warnung

Die Entsorgung dieses Produkts sollte gemäß allen Bestimmungen und Gesetzen des Landes erfolgen.

¡Advertencia!

Al deshacerse por completo de este producto debe seguir todas las leyes y reglamentos nacionales.

## Attention

La mise au rebut ou le recyclage de ce produit sont généralement soumis à des lois et/ou directives de respect de l'environnement. Renseignez-vous auprès de l'organisme compétent.

סילוק המוצר

אזהרה!

סילוק סופי של מוצר זה חייב להיות בהתאם להנחיות וחוקי המדינה.

التخلص النهائي من هذا المنتج ينبغي التعامل معه وفقا لجميع القوانين واللوائح الوطنية عند

경고!

이 제품은 해당 국가의 관련 법규 및 규정에 따라 폐기되어야 합니다.

## Waarschuwing

De uiteindelijke verwijdering van dit product dient te geschieden in overeenstemming met alle nationale wetten en reglementen.

## Fan Warning



**Warning!** Hazardous moving parts. Keep away from moving fan blades. The fans might still be turning when you remove the fan assembly from the chassis. Keep fingers, screwdrivers, and other objects away from the openings in the fan assembly's housing.

ファンの警告

警告!回転部品に注意。運転中は回転部(羽根)に触れないでください。シャーシから冷却ファン装置を取り外した際、ファンがまだ回転している可能性があります。ファンの開口部に、指、ドライバー、およびその他のものを近づけないで下さい。

警告!

警告! 危險的可移動性零件。請務必與轉動的风扇叶片保持距離。當您從機架移除風扇裝置，風扇可能仍在轉動。小心不要將手指、螺絲起子和其他物品太靠近風扇

警告

危險的可移動性零件。請務必與轉動的风扇叶片保持距離。當您從機架移除風扇裝置，風扇可能仍在轉動。小心不要將手指、螺絲起子和其他物品太靠近風扇。

**Warnung**

Gefährlich Bewegende Teile. Von den bewegenden Lüfterblätter fern halten. Die Lüfter drehen sich u. U. noch, wenn die Lüfterbaugruppe aus dem Chassis genommen wird. Halten Sie Finger, Schraubendreher und andere Gegenstände von den Öffnungen des Lüftergehäuses entfernt.

**¡Advertencia!**

Riesgo de piezas móviles. Mantener alejado de las aspas del ventilador. Los ventiladores podran dar vuelta cuando usted quite el montaje del ventilador del chasis. Mantenga los dedos, los destornilladores y todos los objetos lejos de las aberturas del ventilador

**Attention**

Pieces mobiles dangereuses. Se tenir a l'écart des lames du ventilateur Il est possible que les ventilateurs soient toujours en rotation lorsque vous retirerez le bloc ventilateur du châssis. Prenez garde à ce que doigts, tournevis et autres objets soient éloignés du logement du bloc ventilateur.

**אזהרה!**

חלקים נעים מסוכנים. התרחק מלהבי המאוורר בפעולה כאשר מסירים את חלקי המאוורר מהמארז, יתכן והמאווררים עדיין עובדים. יש להרחיק למרחק בטוח את האצבעות וכלי עבודה שונים מהפתחים בתוך המאוורר

تحذير! أجزاء متحركة خطيرة. ابتعد عن شفرات المروحة المتحركة. من الممكن أن المراوح لا تزال تدور عند إزالة كتلة المروحة من الهيكل يجب إبقاء الأصابع ومفكات البراغي وغيرها من الأشياء بعيدا عن الفتحات في كتلة المروحة

**경고!**

움직이는 위험한 부품. 회전하는 송풍 날개에 접근하지 마세요. 새시로부터 팬 조립품을 제거할 때 팬은 여전히 회전하고 있을 수 있습니다. 팬 조립품 외관의 열려있는 부분들로부터 손가락 및 스크류드라이버, 다른 물체들이 가까이 하지 않도록 배치해 주십시오.

**Waarschuwing**

Gevaarlijk bewegende onderdelen. Houd voldoende afstand tot de bewegende ventilatorbladen. Het is mogelijk dat de ventilator nog draait tijdens het verwijderen van het ventilatorsamenstel uit het chassis. Houd uw vingers, schroevendraaiers en eventuele andere voorwerpen uit de buurt van de openingen in de ventilatorbehuizing.

## Power Cable and AC Adapter



**Warning!** When installing the product, use the provided or designated connection cables, power cables and AC adaptors. Using any other cables and adaptors could cause a malfunction or a fire. Electrical Appliance and Material Safety Law prohibits the use of UL or CSA -certified cables (that have UL/CSA shown on the cord) for any other electrical devices than products designated by Supermicro only.

### 電源コードとACアダプター

製品を設置する場合、提供または指定および購入された接続ケーブル、電源コードとACアダプターを該当する地域の条例や安全基準に適合するコードサイズやプラグと共に使用下さい。他のケーブルやアダプタを使用すると故障や火災の原因になることがあります。

電気用品安全法は、ULまたはCSA認定のケーブル(UL/CSAマークがコードに表記)を Supermicro が指定する製品以外に使用することを禁止しています。

### 警告

安装此产品时,请使用本身提供的或指定的或采购的连接线,电源线和电源适配器。包含遵照当地法规和安全要求的合规的电源线尺寸和插头。使用其它线材或适配器可能会引起故障或火灾。除了Supermicro所指定的产品,电气用品和材料安全法律规定禁止使用未经UL或CSA认证的线材。(线材上会显示UL/CSA符号)。

### 警告

安裝此產品時,請使用本身提供的或指定的或採購的連接線,電源線和電源適配器。包含遵照當地法規和安全要求的合規的電源線尺寸和插頭。使用其它線材或適配器可能會引起故障或火災。除了Supermicro所指定的產品,電氣用品和材料安全法律規定禁止使用未經UL或CSA認證的線材。(線材上會顯示UL/CSA符號)。

### Warnung

Nutzen Sie beim Installieren des Produkts ausschließlich die von uns zur Verfügung gestellten Verbindungskabeln, Stromkabeln und/oder Adapter, die Ihre örtlichen Sicherheitsstandards einhalten. Der Gebrauch von anderen Kabeln und Adapter können Fehlfunktionen oder Feuer verursachen. Die Richtlinien untersagen das Nutzen von UL oder CAS zertifizierten Kabeln (mit UL/CSA gekennzeichnet), an Geräten oder Produkten die nicht mit Supermicro gekennzeichnet sind.

## ¡Advertencia!

Cuando instale el producto, utilice la conexión provista o designada o procure cables, Cables de alimentación y adaptadores de CA que cumplan con los códigos locales y los requisitos de seguridad, incluyendo el tamaño adecuado del cable y el enchufe. El uso de otros cables y adaptadores podría causar un mal funcionamiento o un incendio. La Ley de Seguridad de Aparatos Eléctricos y de Materiales prohíbe El uso de cables certificados por UL o CSA (que tienen el certificado UL / CSA en el código) para cualquier otros dispositivos eléctricos que los productos designados únicamente por Supermicro.

## Attention

Lors de l'installation du produit, utilisez les cables de connection fournis ou désigné ou achetez des cables, cables de puissance et adaptateurs respectant les normes locales et les conditions de securite y compris les tailles de cables et les prises electriques appropries. L'utilisation d'autres cables et adaptateurs peut provoquer un dysfonctionnement ou un incendie. Appareils électroménagers et la Loi sur la Sécurité Matériel interdit l'utilisation de câbles certifiés- UL ou CSA (qui ont UL ou CSA indiqué sur le code) pour tous les autres appareils électriques sauf les produits désignés par Supermicro seulement.

AC ימאתמו מיילמשח מילבכ

!הרהזא

ךרוצל ומאתוה וא ושכרנ רשא AC מימאתמו מיקפס, מילבכב שמתשהל שי, רצומה תא מיניקתמ רשאכ לכב שומיש . עקתהו לבכה לש הנוכח הדימ ללוכ, תוימוקמה תוחיטבה תושירדל ומאתוה רשאו, הנקתהה למשחה ירישכמב שומישה יקוחל מאתהב. ילמשח רצק וא הלקתל מורגל לולע, רחא גוסמ מאתמ וא לבכ לש דוק מהילע עיפומ רשאכ) UL-ב או CSA-ב-ב מיכמסומה מילבכב שמתשהל רוסיא מייק, תוחיטבה יקוחו דבלב Supermicro י"ע מאתוה רשא רצומב קר אלא, רחא ילמשח רצומ לכ רובע (UL/CSA)

תאלבאלא אארשב מץ וא אדדחמלא וא ארפוטמלא תאליטוטלא מאדחטסאב מץ, אגתנמלא בייקרת דנע לכלז יפ אמב אילחמלא אמאלסלא תאבלטתמו נינאווקב מאזתלאלא עמ דדרתמלא ראיטלא תאלוחמו אילברמלא קיירח וא לטע יפ בבסטטי דץ ירשא תאלוחמו תאלבאלא יא מאדחטסא. מילסלא סבאלאו לטומוא מץ ח. CSA וא UL לביק נמ אדמטעמלא תאלבאלא מאדחטסא תאדעמלא אילברמלא אזהאלל אמאלסלא נונאק רזחיי Supermicro לביק נמ אדדחמלא אילחמלא תאגתנמלא רייג ירשא תאדעמ יא עמ (UL/CSA) אמאלע למחתיטלאו

### 전원 케이블 및 AC 어댑터

경고! 제품을 설치할 때 현지 코드 및 적절한 굵기의 코드와 플러그를 포함한 안전 요구 사항을 준수하여 제공되거나 지정된 연결 혹은 구매 케이블, 전원 케이블 및 AC 어댑터를 사용하십시오.

다른 케이블이나 어댑터를 사용하면 오작동이나 화재가 발생할 수 있습니다. 전기 용품 안전법은 UL 또는 CSA 인증 케이블 (코드에 UL / CSA가 표시된 케이블)을 Supermicro 가 지정한 제품 이외의 전기 장치에 사용하는 것을 금지합니다.

### Stroomkabel en AC-Adapter

Waarschuwing! Bij het aansluiten van het Product uitsluitend gebruik maken van de geleverde Kabels of een andere geschikte aan te schaffen Aansluitmethode, deze moet altijd voldoen aan de lokale voorschriften en veiligheidsnormen, inclusief de juiste kabeldikte en stekker. Het gebruik van niet geschikte Kabels en/of Adapters kan een storing of brand veroorzaken. Wetgeving voor Elektrische apparatuur en Materiaalveiligheid verbied het gebruik van UL of CSA -gecertificeerde Kabels (met UL/CSA in de code) voor elke andere toepassing dan de door Supermicro hiervoor beoogde Producten.

# Appendix B

## System Specifications

### Processors

Single AMD EPYC™ 9004 Series processor in SP5 socket up to 96 cores

### Chipset

System on Chip

### BIOS

AMI 32 MB SPI Flash EEPROM

### Memory

12 DIMM slots for up to 3 TB of DDR5 ECC RDIMM/LRDIMM with speeds up to 4800 MT/s

### Storage Drives

24 hot-swap 3.5" SAS3/SATA3 drive bays

Two rear hot-swap 2.5" SATA3 drive bays

Two onboard M.2 NVMe slots PCIe 3.0 (22 x 110 mm)

(Optional) Four rear hot-swap 2.5" NVMe U.2 drive bays

### PCI Expansion Slots

Four PCIe 5.0 x16 slots

Two PCIe 5.0 x 8 slots

Two PCIe 5.0 x 16 AIOM slots

(See [Section 3.9](#) for details)

### Input/Output

One RJ45 dedicated IPMI LAN port

Two rear USB 3.0 ports

One rear VGA port

One rear COM port

### Motherboard

H13SSW: 12" (L) x 13" (W) (305 mm x 330 mm)

### Chassis

CSE-826S3TS-R1K62P1: 4U; (WxHxD) 17.2 x 7 x 26.5 in. (437 x 178 x 673 mm)

### System Cooling

Four heavy duty 8-cm fans with optimal fan speed control

One air shroud

**Power Supply**

Model: PWS-1K62A-1R, 1600 W dual redundant modules, 96Plus Titanium level

AC Input

1000 W: 100-127 Vac / 50-60 Hz

1600 W: 200-240 Vac / 50-60 Hz

+12 V

Max: 83.3 A / Min: 0 A (100 Vac-127 Vac)

Max: 133 A / Min: 0 A (200 Vac-240 Vac)

12 V SB

Max: 2.1 A / Min: 0 A

**Operating Environment**

Operating Temperature: 10° to 35° C (50° to 95° F)

Non-operating Temperature: -40° to 60° C (-40° to 140° F)

Operating Relative Humidity: 8% to 90% (non-condensing)

Non-operating Relative Humidity: 5% to 95% (non-condensing)

**Certified Safety Models**

Compliant with UL or CSA: 826-R8X12, 826-8

**Regulatory Compliance**

FCC, ICES, CE, UKCA, VCCI, RCM, NRTL, CB

**Applied Directives, Standards**

EMC/EMI: 2014/30/EU (EMC Directive)

Electromagnetic Compatibility Regulations 2016

FCC Part 15

ICES-003

VCCI-CISPR 32

AS/NZS CISPR 32

BS/EN 55032

BS/EN 55035

CISPR 32

CISPR 35

BS/EN 61000-3-2

BS/EN 61000-3-3

BS/EN 61000-4-2

BS/EN 61000-4-3

BS/EN 61000-4-4

BS/EN 61000-4-5

BS/EN 61000-4-6

BS/EN 61000-4-8

BS/EN 61000-4-11

Product Safety: 2014/35/EU (LVD Directive)

UL/CSA 62368-1 (USA and Canada)

Electrical Equipment (Safety) Regulations 2016

IEC/BS/EN 62368-1

Environment:

2011/65/EU (RoHS Directive)

EC 1907/2006 (REACH)

2012/19/EU (WEEE Directive)

Warning! This product can expose you to chemicals including lead, known to the State of California to cause cancer and birth defects or other reproductive harm. For more information, go to [www.P65Warnings.ca.gov](http://www.P65Warnings.ca.gov).

**Perchlorate Warning**

California Best Management Practices Regulations for Perchlorate Materials: This Perchlorate warning applies only to products containing CR (Manganese Dioxide) Lithium coin cells. Perchlorate Material-special handling may apply. See [www.dtsc.ca.gov/hazardouswaste/perchlorate](http://www.dtsc.ca.gov/hazardouswaste/perchlorate)

この電池は、クラスA廃棄物です。この電池を仕切容器で回収すると市町村費を削減することができます。この場合には使用者が適切な対策を講ずるよう求められることがあります。 VCCI-1-A