

msi[®]

S1205 (1U12)

MS-S321

**Server System
User Guide**

Contents

Regulatory Notices.....	4
Safety Information	7
System Specifications	9
System Overview	11
Block Diagram	14
System Storage Topology	15
System LED Indicators.....	16
Motherboard Overview	17
Motherboard Connectors.....	18
Storage Connectors.....	18
Expansion Slots	21
Power Connectors.....	22
Cooling Connectors.....	23
USB Connectors.....	24
Motherboard Jumpers	32
Motherboard LEDs	33
Getting Started	34
Necessary Tools.....	34
Safety Precautions	34
System Setup.....	35
Drive Bay	35
Installing 2.5" HDD/ SSD.....	35
System Cover.....	36
Removing System Cover	36
CPU & Heatsink	37
Assembly Overview	38
Installing CPU & Heatsink.....	39

Revision

V1.4, 2026/04

Memory	41
Recommended Memory Population	42
Installing Memory Modules.....	44
M.2 M Key	45
Installing M.2 M Key.....	45
PCIe Add-in Card	46
Installing PCIe Add-in Card	46
Installing Riser Card Assembly	47
System Fan.....	48
Installing 1U Fan.....	48
Power Supply Unit (PSU)	49
Installing PSU	49
Cable Routing.....	50
Slide Rail.....	52
Disassembling Slide Rail	52
Installing Inner Rail to System	53
Retracting Outer Rail Bracket	54
Attaching Outer Rail Bracket to Rack Frame	54
Installing System into Rack.....	55
Detaching Outer Rail Bracket from Rack Frame.....	56
Detaching Inner Rail from System	56

Regulatory Notices

WEEE Statement

European Union: This symbol on the product indicates that this product cannot be discarded as municipal waste. Instead, it is your responsibility to dispose of your waste electrical and electronic equipment by handing it over to a designated collection point for recycling. For more information about where you can drop off your waste equipment for recycling, please contact your local city office, your household waste disposal service or the shop where you purchased the product.



CE Conformity

This product has been tested and found to comply with the harmonized standards for Information Technology Equipment published under Directives of Official Journal of the European Union.



FCC-A Radio Frequency Interference Statement

This equipment has been tested and found to comply with the limits for a Class A digital device, pursuant to Part 15 of the FCC Rules. These limits are designed to provide reasonable protection against harmful interference when the equipment is operated in a commercial environment. This equipment generates, uses and can radiate radio frequency energy and, if not installed and used in accordance with the instruction manual, may cause harmful interference to radio communications. Operation of this equipment in a residential area is likely to cause harmful interference, in which case the user will be required to correct the interference at his own expense.



Notice 1

The changes or modifications not expressly approved by the party responsible for compliance could void the user's authority to operate the equipment.

Notice 2

Shielded interface cables and AC power cord, if any, must be used in order to comply with the emission limits.

This device complies with Part 15 of the FCC Rules. Operation is subject to the following two conditions:

- This device may not cause harmful interference, and
- This device must accept any interference received, including interference that may cause undesired operation.

Chemical Substances Information

In compliance with chemical substances regulations, such as the EU REACH Regulation (Regulation EC No. 1907/2006 of the European Parliament and the Council), MSI provides the information of chemical substances in products at:

<https://csr.msi.com/global/index>

Battery Information

Please take special precautions if this product comes with a battery.

- Danger of explosion if battery is incorrectly replaced. Replace only with the same or equivalent type recommended by the manufacturer.
- Avoid disposal of a battery into fire or a hot oven, or mechanically crushing or cutting of a battery, which can result in an explosion.
- Avoid leaving a battery in an extremely high temperature or extremely low air pressure environment that can result in an explosion or the leakage of flammable liquid or gas.
- Do not ingest battery. If the coin/button cell battery is swallowed, it can cause severe internal burns and can lead to death. Keep new and used batteries away from children.

European Union:



Batteries, battery packs, and accumulators should not be disposed of as unsorted household waste. Please use the public collection system to return, recycle, or treat them in compliance with the local regulations.

BSMI:



廢電池請回收

For better environmental protection, waste batteries should be collected separately for recycling or special disposal.

California, USA:



The button cell battery may contain perchlorate material and requires special handling when recycled or disposed of in California. For further information please visit:

<http://www.dtsc.ca.gov/hazardouswaste/perchlorate/>

Environmental Policy

- The product has been designed to enable proper reuse of parts and recycling and should not be thrown away at its end of life.
- Users should contact the local authorized point of collection for recycling and disposing of their end-of-life products.
- Visit the MSI website <https://csr.msi.com/global/pevn_ewaste> and locate a nearby distributor for further recycling information.
- Please visit <<https://us.msi.com/page/recycling>> for information regarding the recycling of your product in the US.



Copyright and Trademarks Notice

msi

MSI

微星

微星科技
MICRO-STAR INTERNATIONAL



Copyright © Micro-Star Int'l Co., Ltd. All rights reserved. The MSI logo used is a registered trademark of Micro-Star Int'l Co., Ltd. All other marks and names mentioned may be trademarks of their respective owners. No warranty as to accuracy or completeness is expressed or implied. MSI reserves the right to make changes to this document without prior notice.

Technical Support

If a problem arises with your product and no solution can be obtained from the user's manual, please contact your place of purchase or local distributor. Alternatively, please visit <https://eps.msi.com/support> for further guidance.

Safety Information



Please read and follow these safety instructions carefully before installing, operating or performing maintenance on the server.

General Safety Instructions

- Always read the safety instructions carefully.
- Keep this User Guide for future reference.
- Keep this equipment away from humidity.
- Lay the equipment on a stable, flat surface before setting it up.
- Do not cover the air openings to prevent overheating.
- Avoid spilling liquids into the equipment to prevent damage or electrical shock.
- Do not leave the equipment in an unconditioned environment. Storage temperatures above 60°C (140°F) may cause damage.

Electrical Safety

Power Setup and Protection

- Ensure the power source matches the equipment voltage before connection.
- Plug the power cord into a grounded (earthed) electrical outlet that is easily accessible at all times. Do not disable the power cord grounding plug, as it is an important safety feature.
- Do not use a power adapter other than the one provided.
- Place the power cord to avoid being stepped on or crushed.
- Protect the server from power fluctuations and outages using a regulated uninterruptible power supply (UPS).

Handling Power Connections

- Unplug the power cord before inserting add-on cards or modules.
- Disconnect all power supplies before maintenance to avoid electrical shock. If the unit has more than one power supply, disconnect all of them.
- Unplug the power cord to fully disconnect the system. The front panel Power On/Standby button does not completely shut off system power. Portions of the power supply and some internal circuitry remain active until AC/DC power is removed.

Assembly and Installation

This equipment must be installed in restricted access areas by qualified personnel to comply with safety standards set by the NEC and IEC 62368-1, Third Edition, for Information Technology Equipment.

Lifting and Placement

WARNING: This server is heavy.

- Follow occupational health and safety guidelines for manual material handling.
- A minimum of two people is required to lift or install the server. For installations above chest height, a third person may be needed for alignment.
- Exercise caution when installing or removing the server from the rack, as it may become unstable when not fastened to the rails.

Hot Surfaces

- Allow components like drives and power supplies to cool before touching.

Energy Pack Handling after Removal

To reduce the risk of fire or burns:

- Do not disassemble, crush, or puncture the energy pack.
- Avoid shorting external contacts.
- Do not dispose of the energy pack in fire or water.

Other Components

- Keep away from hazardous moving parts, such as fan blades, to prevent injury.
- Do not drop or jolt the system, as this may damage internal components or compromise safety.

General Precautions During Operation

- Avoid operating the server with the access panel open or removed for extended periods, as this disrupts airflow and may cause overheating.
- Do not insert incorrect connectors into ports to avoid damage to components or the risk of electrical hazards.
- This equipment is not suitable for use in locations where children are likely to be present.

When to Contact Service Personnel

Seek immediate assistance from qualified personnel if any of the following occurs:

- The power cord or plug is damaged.
- Liquid has entered the equipment.
- The equipment has been exposed to moisture.
- The equipment does not function as described in the User Guide.
- The equipment has been dropped or physically damaged.
- The equipment shows visible signs of breakage.

System Specifications





SKUs	S1205-01	S1205-01-10G
Form factor	1U	
Dimensions	438mm(17.2") W x 43.2mm(1.7")H x 770mm(30.3")D	
Processor	Dual 4th/5th Gen Intel® Xeon® Scalable processors, TDP up to 350W	
Socket	2 x Intel LGA 4677 (Socket E)	
Chipset	Intel® C741 Chipset	
Networking	<ul style="list-style-type: none"> • No onboard LAN • 2 x GbE RJ45 ports <ul style="list-style-type: none"> - Through M.2 LAN module NAD-101 (optional) 	<ul style="list-style-type: none"> • 2 x 10GSFP+ LAN ports <ul style="list-style-type: none"> - Intel® LAN controller X710-BM2 - Through OCP NIC 3.0 LAN adapter OCP-321 • 2 x GbE RJ45 ports <ul style="list-style-type: none"> - Through M.2 LAN module NAD-101 (optional)
RAID	Intel® SATA RAID 0/1/10/5	
Memory	<ul style="list-style-type: none"> • 32 x DDR5 DIMM slots, 16 channels (2DPC), RDIMM/ 3DS-RDIMM <ul style="list-style-type: none"> - Max Frequency: <ul style="list-style-type: none"> » 5th Gen Intel® Xeon®: 5600 MT/s (1DPC), 4400 MT/s (2DPC) » 4th Gen Intel® Xeon®: 4800 MT/s (1DPC), 4400 MT/s (2DPC) - Max Capacity per DIMM: <ul style="list-style-type: none"> » RDIMM: 96GB (DDR5-4800)/ 128GB (DDR5-5600) » 3DS-RDIMM: 256GB 	
Drive Bays	<ul style="list-style-type: none"> • 12 x 2.5" hot-swap drive bays <ul style="list-style-type: none"> - Supports U.2 PCIe 4.0 NVMe signals 	
Internal Storage	2 x M.2 M-key (PCIe 3.0 x2, 2280/ 22110) (from PCH)	
Expansion Slots	<ul style="list-style-type: none"> • 3 x PCIe slots <ul style="list-style-type: none"> - RISER1: <ul style="list-style-type: none"> » 1 x PCIe 4.0 x16 slot (PCIe 4.0 x16 signal, from CPU0, supporting LP PCIe card) - RISER2: <ul style="list-style-type: none"> » 1 x PCIe 4.0 x16 slot (PCIe 4.0 x16 signal, from CPU1, supporting LP PCIe card) - RISER4: <ul style="list-style-type: none"> » 1 x PCIe 3.0 x16 slot (PCIe 3.0 x16 signal, from CPU1, supporting LP PCIe card) • 1 x OCP 3.0 Mezzanine card slot (PCIe 4.0 x16 signal, from CPU0) <ul style="list-style-type: none"> - Supports NCSI 	

Continued on next column

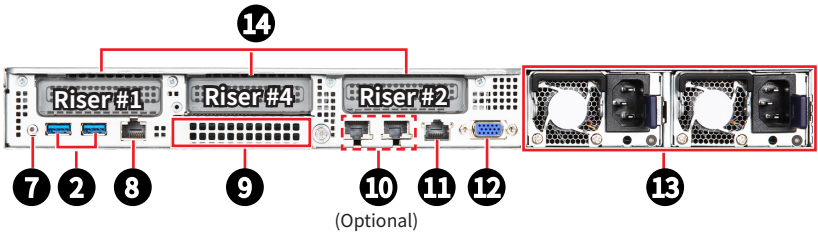
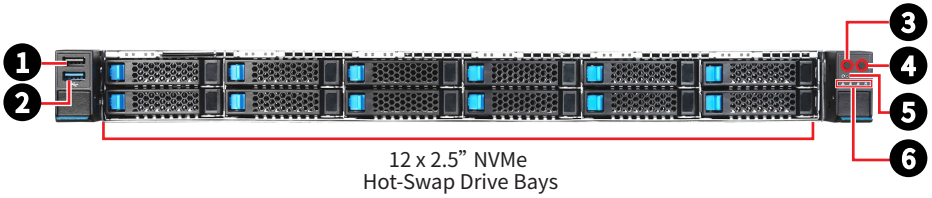
SKUs	S1205-01	S1205-01-10G
Front Panel	<ul style="list-style-type: none"> • 1 x USB 3.0 Type-A port • 1 x USB 2.0 Type-A port • 1 x System power LED button • 1 x UID LED button • 1 x Reset button • 4 x Status LEDs (M.2/ Alarm/ 2 x LANs) 	
Rear Panel	<ul style="list-style-type: none"> • 1 x GbE RJ45 Port (mgmt.) • 2 x USB 3.0 Type-A ports • 1 x COM RJ45 port • 1 x VGA port • 1 x UID LED button* <p>*The UID LED button can also function as a BMC reset button by configuring jumper: J1_1.</p>	
TPM	1 x TPM header (with SPI interface)	
Security	TPM 2.0	
Server Management	<ul style="list-style-type: none"> • 1 x GbE RJ45 Port (mgmt.) (Realtek® RTL8211FD-CG) • 1 x MicroSD card slot (for BMC log) • ASPEED AST2600 with AMI MegaRAC based firmware <ul style="list-style-type: none"> - Supports IPMI 2.0 and DMTF Redfish® API • Dual BIOS and BMC supported 	
Cooling	<ul style="list-style-type: none"> • 2 x Passive air cooling modules (for max 205W CPU) • 8 x 4056 easy-swap system fans 	
Environment	<ul style="list-style-type: none"> • Operating Temperature: 0°C ~ 35°C • Non-operating Temperature: -20°C ~ 70°C • Non-operating Relative Humidity: 5% ~ 85% (non-condensing) 	
Power Supply	(1+1) 1300W CRPS, 80 PLUS® Platinum	
Certification	CE, FCC (Class A)	

System Overview



<p>1</p>	<p>USB 2.0 Type-A Port</p> <p>This connector is provided for USB peripheral devices. (Speed up to 480 Mbps)</p> <p> Important</p> <p><i>High-speed devices are recommended for USB 3.2 ports whereas low-speed devices, such as mouse or keyboard, are suggested to be plugged into the USB 2.0 ports.</i></p>
<p>2</p>	<p>USB 3.0 Type-A Port</p> <p>This connector is provided for USB peripheral devices.</p>
<p>3</p>	<p> System Power Button/ LED</p>
<p>4</p>	<p>UID Button/ LED</p>
<p>5</p>	<p>System Reset Button</p>
<p>6</p>	<p> System Alarm LED</p> <p> NIC Link LEDs</p> <p> M.2 Activity LED</p>
<p>7</p>	<p>UID LED Button (or BMC Reset Button, configured using jumper: J1_1)</p>
<p>8</p>	<p>COM RJ45 Port</p>
<p>9</p>	<p>OCP Mezzanine card slot</p>

Continued on next column

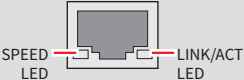
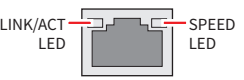
10	GbE RJ45 Port (Optional) The standard RJ45 LAN jack is provided for connection to the Local Area Network (LAN). You can connect a network cable to it.																		
		<table border="1"> <thead> <tr> <th>LED</th> <th>Status</th> <th>Description</th> </tr> </thead> <tbody> <tr> <td rowspan="3">Link/ Activity LED</td> <td>○ Off</td> <td>No link</td> </tr> <tr> <td>● Green</td> <td>Linked</td> </tr> <tr> <td>◐ Blinking</td> <td>Data activity</td> </tr> <tr> <td rowspan="3">Speed LED</td> <td>○ Off</td> <td>10 Mbps/ No LAN linked</td> </tr> <tr> <td>● Orange</td> <td>100 Mbps</td> </tr> <tr> <td>● Green</td> <td>1 Gbps</td> </tr> </tbody> </table>	LED	Status	Description	Link/ Activity LED	○ Off	No link	● Green	Linked	◐ Blinking	Data activity	Speed LED	○ Off	10 Mbps/ No LAN linked	● Orange	100 Mbps	● Green	1 Gbps
LED	Status	Description																	
Link/ Activity LED	○ Off	No link																	
	● Green	Linked																	
	◐ Blinking	Data activity																	
Speed LED	○ Off	10 Mbps/ No LAN linked																	
	● Orange	100 Mbps																	
	● Green	1 Gbps																	
11	GbE RJ45 Port (mgmt.) Provides a 1 Gbps RJ45 dedicated out-of-band management interface connected to the BMC. Use this port for system management, monitoring, and remote access.																		
		<table border="1"> <thead> <tr> <th>LED</th> <th>Status</th> <th>Description</th> </tr> </thead> <tbody> <tr> <td rowspan="3">Link/ Activity LED</td> <td>○ Off</td> <td>No link</td> </tr> <tr> <td>● Green</td> <td>Linked</td> </tr> <tr> <td>◐ Blinking</td> <td>Data activity</td> </tr> <tr> <td rowspan="3">Speed LED</td> <td>○ Off</td> <td>10 Mbps</td> </tr> <tr> <td>● Orange</td> <td>100 Mbps</td> </tr> <tr> <td>● Green</td> <td>1 Gbps</td> </tr> </tbody> </table>	LED	Status	Description	Link/ Activity LED	○ Off	No link	● Green	Linked	◐ Blinking	Data activity	Speed LED	○ Off	10 Mbps	● Orange	100 Mbps	● Green	1 Gbps
LED	Status	Description																	
Link/ Activity LED	○ Off	No link																	
	● Green	Linked																	
	◐ Blinking	Data activity																	
Speed LED	○ Off	10 Mbps																	
	● Orange	100 Mbps																	
	● Green	1 Gbps																	
12	VGA Port																		
13	Power Supply Unit																		
14	PCIe Add-in Card Area																		

Block Diagram

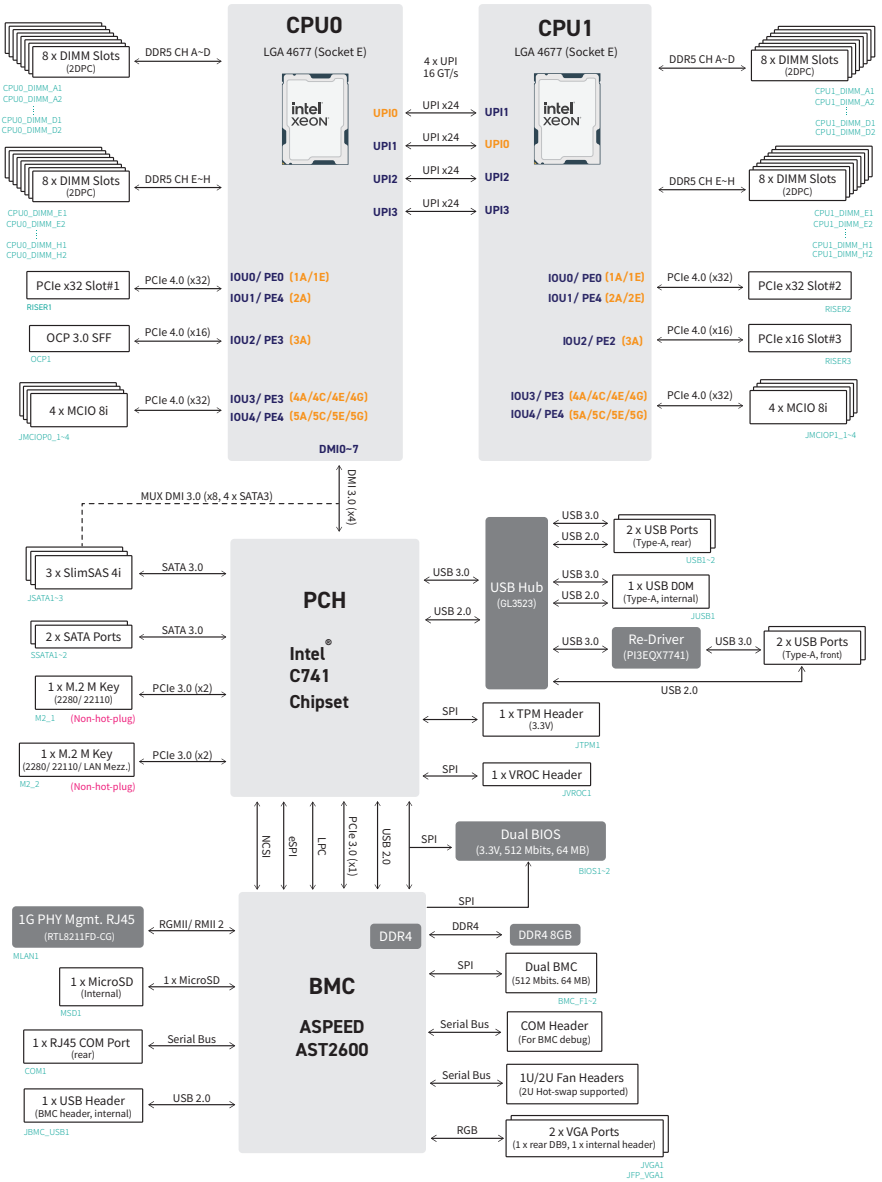

System Storage Topology



12 x NVMe Signal					
#11	#9	#7	#5	#3	#1
NVMe	NVMe	NVMe	NVMe	NVMe	NVMe
CPU1 PE3	CPU1 PE3	CPU0 PE4	CPU0 PE4	CPU0 PE3	CPU0 PE3
Port 4E	Port 4A	Port 5E	Port 5A	Port 4E	Port 4A
Lanes 8:11	Lanes 0:3	Lanes 8:11	Lanes 0:3	Lanes 8:11	Lanes 0:3
#12	#10	#8	#6	#4	#2
NVMe	NVMe	NVMe	NVMe	NVMe	NVMe
CPU1 PE3	CPU1 PE3	CPU0 PE4	CPU0 PE4	CPU0 PE3	CPU0 PE3
Port 4G	Port 4C	Port 5G	Port 5C	Port 4G	Port 4C
Lanes 12:15	Lanes 4:7	Lanes 12:15	Lanes 4:7	Lanes 12:15	Lanes 4:7

System LED Indicators

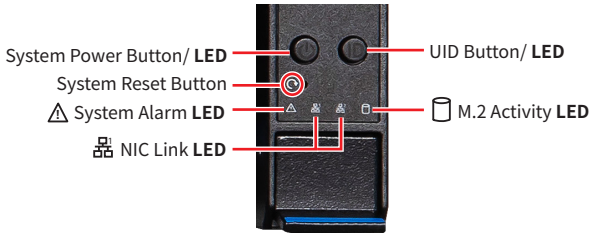

LED	LED State	Description
System Power LED	● Blue	System power is on
		System power is on ACPI S0 state
	◐ Blinking	System is sleeping
	○ Off	System power is off
UID LED	● Blue	Identify active via command or button
	○ Off	No identification
⚠ System Alarm LED	● Green	BMC initialization
	● Red	System has failed
	○ Off	System is running/ normal operation
🔌 NIC Link LED	◐ Blinking	NIC activity is occurring
	○ Off	NIC link is not established
🗄 M.2 Activity LED	● Amber	M.2 present, no activity
	◐ Blinking	M.2 accessing
	○ Off	No M.2 activity

Motherboard Overview

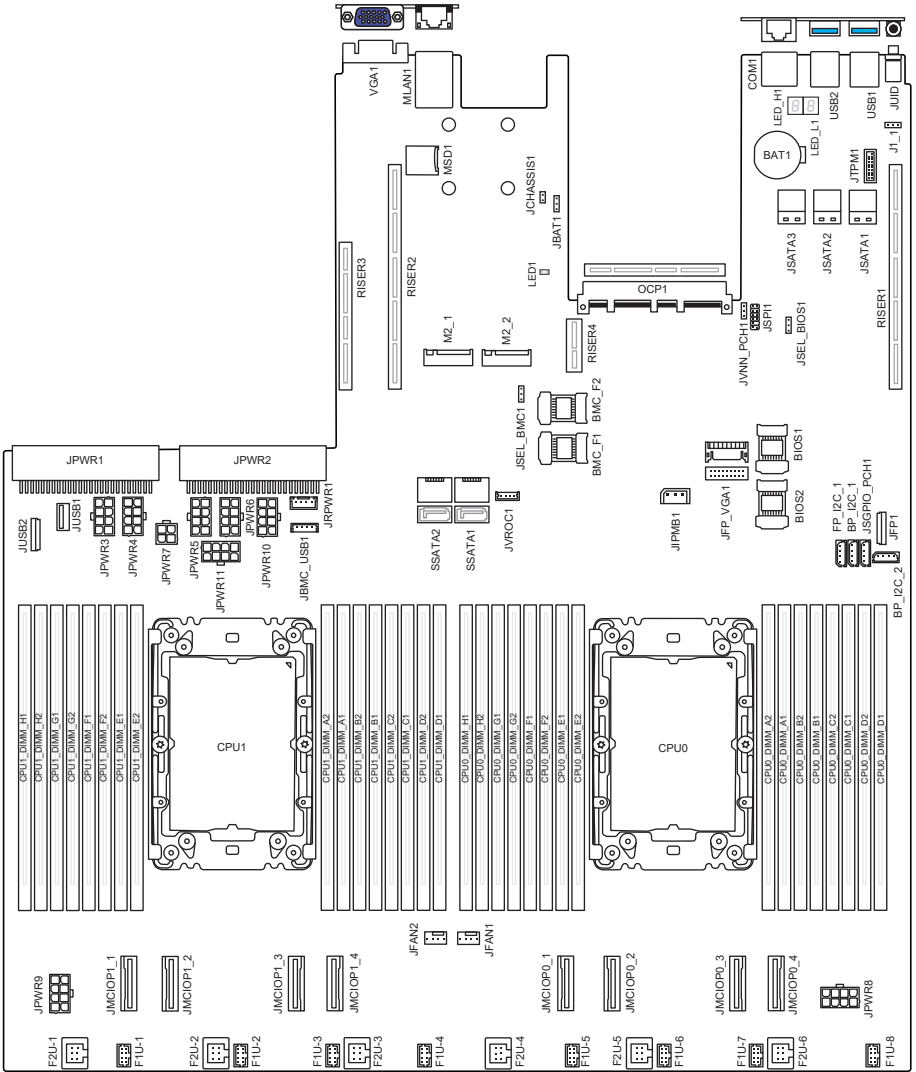

Motherboard Connectors

Storage Connectors

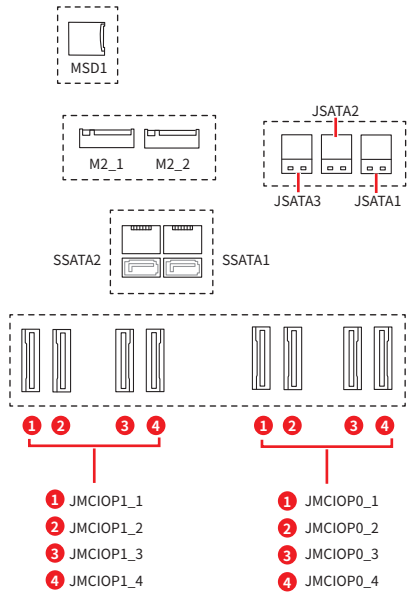
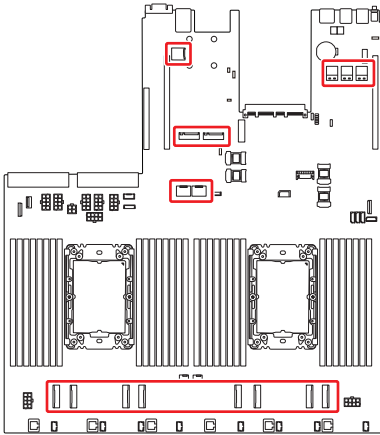

Name	Description
SSATA1~2	SATA 3.0, 6Gb/s
JSATA1~3	SATA 3.0, 6Gb/s
M2_1~2	PCIe 3.0 x2, 8GT/s
JMCIOP0_1~4	PCIe 4.0 x8, 16GT/s
JMCIOP1_1~4	

M2_1, M2_2: M.2 Slot (M Key, PCIe 3.0 x2, 22110/ 2280)

The M.2 slot supports solid-state drive (SSD). For Installation procedure, please refer to "[System Setup > M.2 M Key](#)".

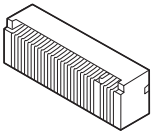

MSD1: Micro SD Card Slot

This slot is for inserting the micro SD card.

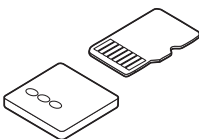

JSATA1~3: Slimline SAS 4i Connectors

These connectors provide storage support for SATA devices.

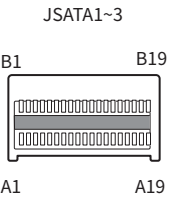
 <p>JSATA1~3</p>	A1	GND	B1	GND
	A2	JSATA_P0_RX+	B2	JSATA_P0_TX+
	A3	JSATA_P0_RX-	B3	JSATA_P0_TX-
	A4	GND	B4	GND
	A5	JSATA_P1_RX+	B5	JSATA_P1_TX+
	A6	JSATA_P1_RX-	B6	JSATA_P1_TX-
	A7	GND	B7	GND
	A8	BP TYPE	B8	SGPIO_SATA_CLOCK_R
	A9	SGPIO_SATA_DATAOUT_R	B9	SGPIO_SATA_LOAD_R
	A10	GND	B10	GND
	A11	NC	B11	P3V3
	A12	NC	B12	NC
	A13	GND	B13	GND
	A14	JSATA_P2_RX+	B14	JSATA_P2_TX+
	A15	JSATA_P2_RX-	B15	JSATA_P2_TX-
	A16	GND	B16	GND
	A17	JSATA_P3_RX+	B17	JSATA_P3_TX+
	A18	JSATA_P3_RX-	B18	JSATA_P3_TX-
	A19	GND	B19	GND

SSATA1~2: SATA 3.0 DOM Ports (6Gb/s)

These connectors are SATA 6Gb/s interface ports. Each connector can connect to one SATA device.

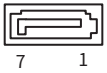
 <p>SSATA1~2</p>	1	GND	5	TX_DN
	2	RX_DP	6	TX_DP
	3	RX_DN	7	GND
	4	GND		

Important

- Please do not fold the SATA cable at a 90-degree angle. Data loss may result during transmission otherwise.
- SATA cables have identical plugs on either sides of the cable. However, it is recommended that the flat connector be connected to the motherboard for space saving purposes.

JMCIOP0_1~4, JMCIOP1_1~4: MCIO 8i Connectors

These are vertical 74-pin Mini Cool Edge IO (MCIO) connectors, which support PCIe 4.0 x8 16GT/s interface.

A1	GND	B1	GND
A2	SSD_RX+	B2	SSD_TX+
A3	SSD_RX-	B3	SSD_TX-
A4	GND	B4	GND
A5	SSD_RX+	B5	SSD_TX+
A6	SSD_RX-	B6	SSD_TX-
A7	GND	B7	GND
A8	NC	B8	SMB_PEHPCPU_LV3_SCL
A9	FM_SMB_CPU_ALERT_N	B9	SMB_PEHPCPU_LV3_SDA
A10	GND	B10	GND
A11	CLK_100M_SSD_DP	B11	RST_PCIE_CPU_PERST_N
A12	CLK_100M_SSD_DN	B12	FM_PCIE_SSD_PRSNNT_N
A13	GND	B13	GND
A14	SSD_RX+	B14	SSD_TX+
A15	SSD_RX-	B15	SSD_TX-
A16	GND	B16	GND
A17	SSD_RX+	B17	SSD_TX+
A18	SSD_RX-	B18	SSD_TX-
A19	GND	B19	GND
A20	SSD_RX+	B20	SSD_TX+
A21	SSD_RX-	B21	SSD_TX-
A22	GND	B22	GND
A23	SSD_RX+	B23	SSD_TX+
A24	SSD_RX-	B24	SSD_TX-
A25	GND	B25	GND
A26	NC	B26	SMB_PEHPCPU_LV3_SCL
A27	FM_SMB_CPU_ALERT_N	B27	SMB_PEHPCPU_LV3_SDA
A28	GND	B28	GND
A29	CLK_100M_SSD_DP	B29	RST_PCIE_CPU_PESST_N
A30	CLK_100M_SSD_DN	B30	FM_PCIE_SSD_PRSNNT_N
A31	GND	B31	GND
A32	SSD_RX+	B32	SSD_TX+
A33	SSD_RX-	B33	SSD_TX-
A34	GND	B34	GND
A35	SSD_RX+	B35	SSD_TX+
A36	SSD_RX-	B36	SSD_TX-
A37	GND	B37	GND

JMCIOP0_1~4

JMCIOP1_1~4

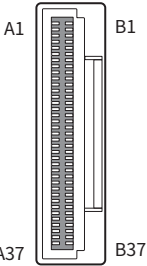

Expansion Slots

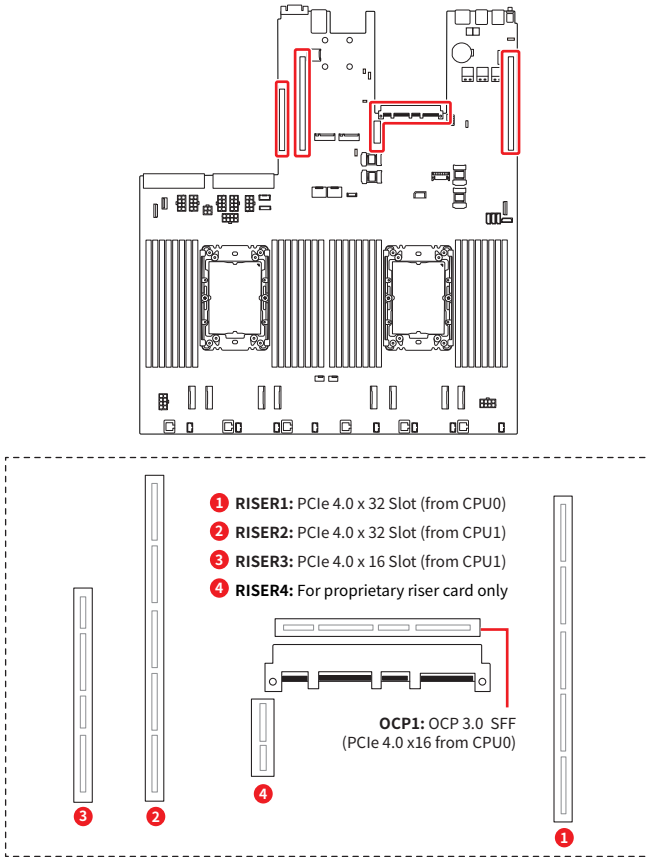

RISER1~4: PCIe Expansion Slots

The PCI Express(Peripheral Component Interconnect Express) slots support PCIe interface expansion cards.

OCP1: OCP (Open Compute Project) LAN Mezzanine Slot

The slots allows the deployment of a wide variety of additional networking options through OCP Mezzanine Ethernet cards.

Important

When adding or removing expansion cards, make sure that you unplug the power supply first. Meanwhile, read the documentation for the expansion card to configure any necessary hardware or software settings for the expansion card, such as jumpers, switches or BIOS configuration.

Power Connectors

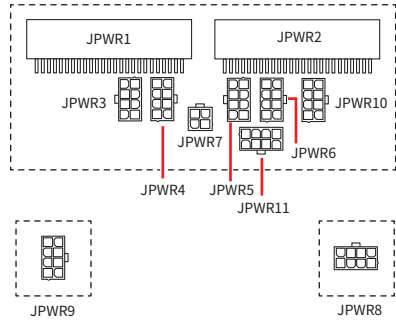
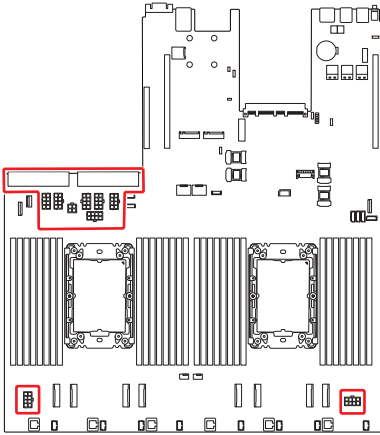

JPWR1~2: CRPS Power Connectors

These CRPS (Common Redundant Power Supplies) connectors allow you to connect a power supply. To connect the power supply, ensure that the plug is inserted in the proper orientation and that the pins are aligned. Then firmly push down the power supply into the connector.

JPWR3~6, JPWR10~11: 8-Pin GPU Power Connectors

These connectors provide power output to GPUs.

JPWR8~9: 8-Pin HDD BP Power Connectors

These connectors provide power output to HDDs.

JPWR3	JPWR8		1	GND	2	GND
JPWR4	JPWR9		3	GND	4	GND
JPWR5	JPWR10		5	+12V	6	+12V
JPWR6	JPWR11		7	+12V	8	+12V

JPWR7: 4-Pin Rear BP Power Connector

This connector provides power output to HDDs on rear side.

JPWR7	1		2	GND	2	GND
	3		3	P12V	4	P5V

Important

Make sure that all power connectors are securely connected to the power supply to ensure stable operation of the motherboard.

Cooling Connectors

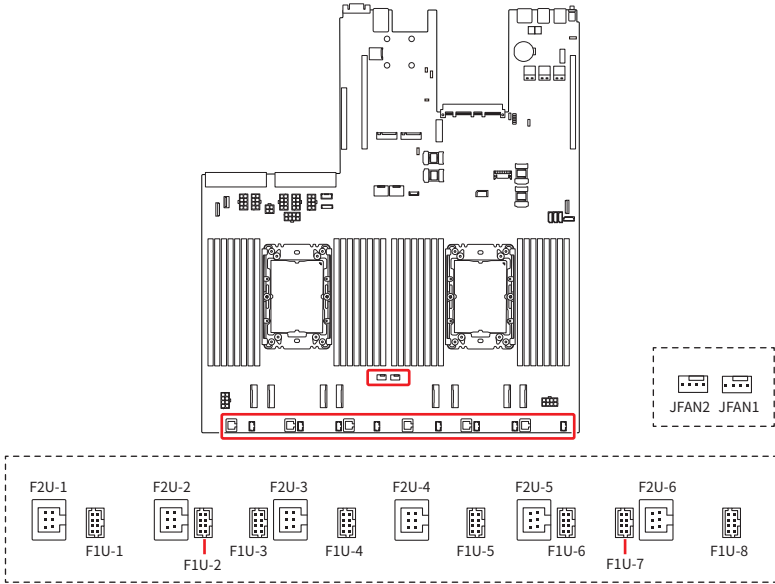

F2U1~6: 2U System Fan Connectors

The fan power connectors support 2U system cooling fans.

	1	GND	2	P12V
	3	FAN_TACH	4	BMC_PWM
	5	FAN_PRSN	6	FAN_FAULT

F1U1~8: 1U System Fan Connectors

The fan power connectors support 1U system cooling fans.

	1	FAN_TACH	2	FAN_PWM
	3	P12V	4	P12V
	5	FAN_TACH	6	GND
	7	GND	8	FAN_PRSN

JFAN1~2: CPU Fan Connectors

The fan power connectors support CPU cooling fans.

	1	GND	3	FAN SENSE
	2	P12V	4	FAN_PWM

USB Connectors

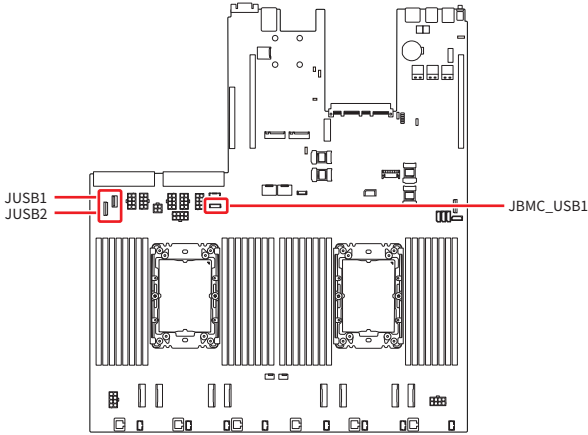

JUSB1: USB 2.0 Type-A Port

The USB (Universal Serial Bus) port is for attaching USB devices such as keyboard, mouse, or other USB-compatible devices. It supports up to **480 Mbps** data transfer rate.

JUSB1



JUSB2: USB 2.0 FPC Connector

This port supports USB 2.0 devices with data transfer rate up to **480 Mbps**.

	1	USB_VCC1	2	USB_VCC1
	3	USB_VCC1	4	USB_VCC1
	5	USB_VCC1	6	USB_VCC1
	7	GND	8	GND
	9	GND	10	GND
	11	GND	12	GND
	13	GND	14	GND
	15	USB3_P04_ESD_RXN	16	USB3_P04_ESD_RXP
	17	GND	18	USB3_P04_ESD_TXN
	19	USB3_P04_ESD_TXP	20	GND
	21	PCH_USB2_P02_ESD_DN	22	PCH_USB2_P02_ESD_DP
	23	GND	24	PCH_USB2_P03_ESD_DN
	25	PCH_USB2_P03_ESD_DP	26	GND

JBMC_USB1: BMC USB 2.0 Header

This connector is used to connect USB devices and link to BMC for applications.

JBMC_USB1	1		4	1	P5V_AUX	3	BMC_USB2B_HOST_DN
				2	BMC_USB2B_HOST_DP	4	GND

Other Connectors and Components

JFP1: Front Panel FPC Connector

The front panel connector is provided for electrical connection to the front panel switches and LEDs.

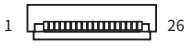
 <p style="text-align: center;">JFP1</p>	1	P3V3_AUX	2	P3V3_AUX
	3	N/A	4	FP ID LED+
	5	PWR_LED-	6	FP ID LED-
	7	P3V3	8	SYS_FLT_LED-
	9	SYS_ERR_LED-	10	M.2 SSD_ACT_LED-
	11	PWR_ON_BTN-	12	NIC1_LED+
	13	GND	14	NIC1_LED-
	15	SYS_RST_BTN-	16	SMB_DAT
	17	SMB_CLK	18	GND
	19	FP_ID_BTN-	20	N/A
	21	N/A	22	N/A
	23	NIC2_LED+	24	NIC2_LED-
	25	GND	26	GND

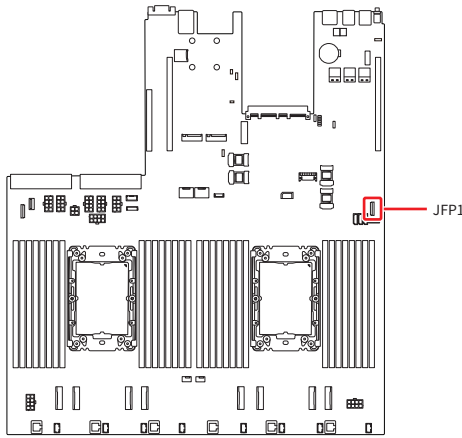

JTPM1: SPI TPM Header

This header connects to a TPM (Trusted Platform Module) module (optional). Please refer to the TPM security platform manual for more details.

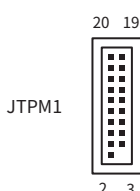
	1	N/A	2	SPI_PCH_CS0_N
	3	R_ST_RSMRST_N	4	N/A
	5	GND	6	P3V3_AUX
	7	SPI_PCH_CLK	8	SPI_PCH_IO2
	9	SPI_PCH_IO3	10	SPI_PCH_MISO
	11	N/A	12	SPI_PCH_MOSI
	13	SPI_PCH_TPM_DEDIPROG_CS_N	14	GND
	15	P3V3_AUX	16	N/A
	17	IRQ_TPM_SPI_N	18	P3V3_AUX
	19	RST_PLTRST_B_N	20	P3V3_AUX

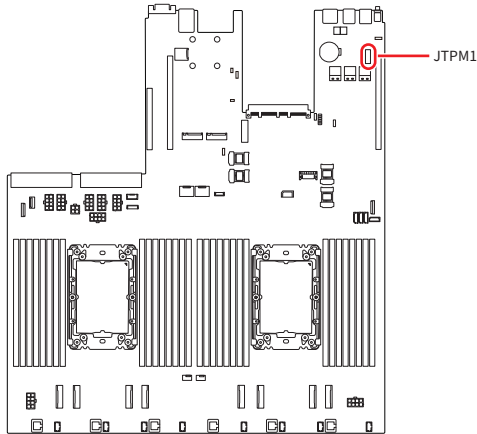

JFP_VGA1: Front VGA Header

The VGA header is provided for monitors.

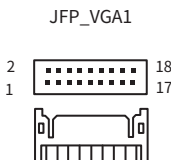
 <p style="text-align: center;">JFP_VGA1</p>	1	N/A	2	N/A
	3	F_RED	4	GND
	5	F_GRN	6	GND
	7	F_BLU	8	GND
	9	F_VS	10	GND
	11	F_HS	12	GND
	13	F_DDCDAT	14	SEL_FP_N
	15	F_DDCCLK	16	F_VGA_5V
	17	N/A	18	N/A

JIPMB1: IPMB Header

This header is used to connect the Intelligent Platform Management Bus.

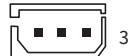
 <p style="text-align: center;">JIPMB1</p>	1	SMBUS_DATA
	2	GND
	3	SMBUS_CLK

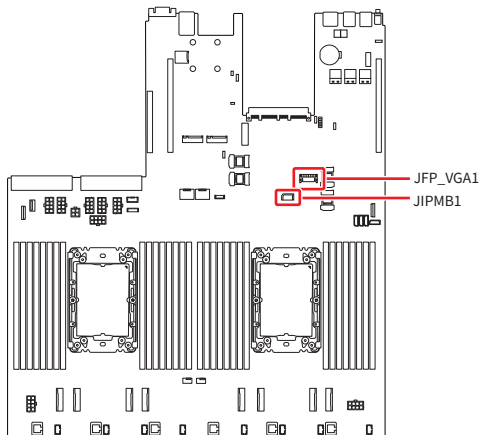

JVROC1: VROC Header

Intel® Virtual RAID on CPU (Intel® VROC) is a RAID solution specifically designed for NVMe SSDs connected directly to the CPU.

JVROC1		1	GND	3	GND
		2	PU_KEY_CONN_PIN2_R	4	FM_PCH_SATA_RAID_KEY_R

FP_I2C_1, BP_I2C_1~2: I2C Headers

These headers, known as I2C, are provided for users to connect System Management Bus (SMBus) interface.

FP_I2C_1 BP_I2C_1 BP_I2C_2		1	NC	3	GND
		2	SMB_CLK	4	SMB_DAT

JSGPIO_PCH1: Rear BP SGPIO Header

JSGPIO_PCH1		1	SGPIO_SATA_CLOCK_RBP	3	GND
		2	SGPIO_SATA_LOAD_RBP	4	SGPIO_SATA_DATAOUT_RBP

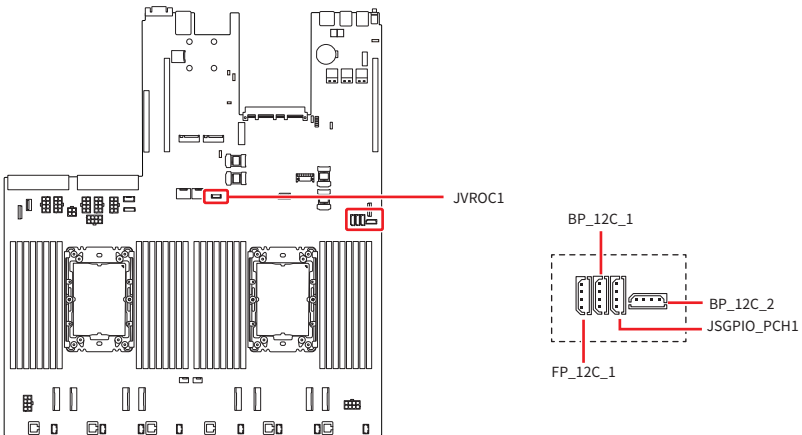

JCHASSIS1: Chassis Intrusion Header

This header connects to the chassis intrusion switch cable. If the chassis is opened, the chassis intrusion mechanism will be activated. The system will record this status and show a warning message on the screen. To clear the warning, you must enter the BIOS utility and clear the record.

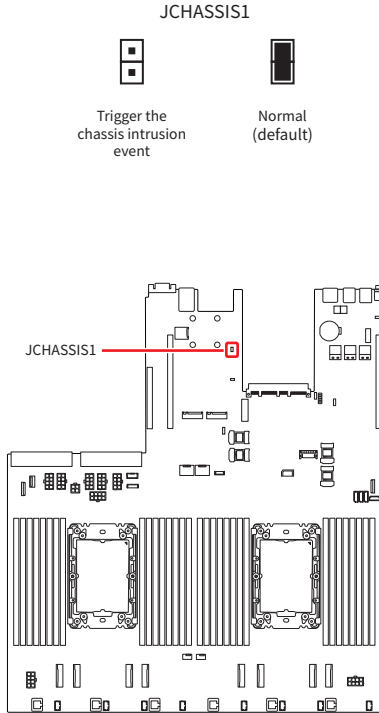

BAT1: CMOS Battery

If the CMOS battery is out of charge, the time in the BIOS will be reset and the data of system configuration will be lost. In this case, you need to replace the CMOS battery.

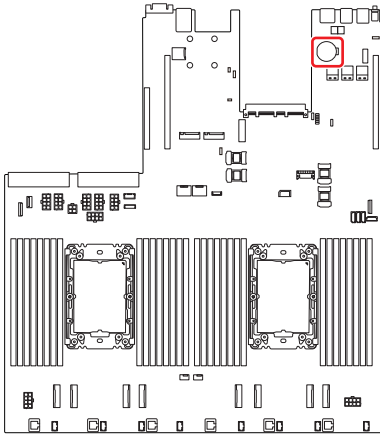

Replacing CMOS battery

1. Push the retainer clip to free the battery.
2. Remove the battery from the socket.
3. Install the new CR2032 coin-cell battery with the + sign facing up. Ensure that the retainer holds the battery securely.

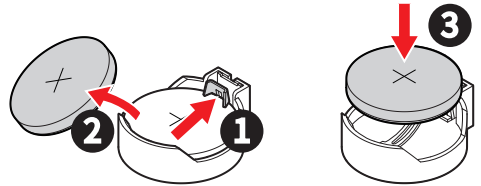

WARNING

KEEP OUT OF REACH OF CHILDREN

- Swallowing can cause chemical burns, perforation of soft tissue, and even death.
- Severe burns can occur within 2 hours of ingestion.
- If you think batteries might have been swallowed or placed inside any part of the body, seek immediate medical attention.





Motherboard Jumpers

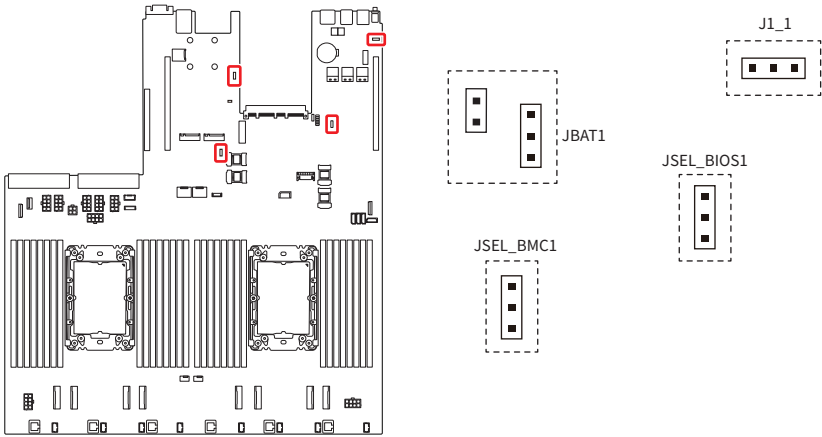

Important

Avoid adjusting jumpers when the system is on; it will damage the motherboard.



Jumper Name	Default Setting	Description
JSEL_BIOS1	 1	1-2: BIOS1 & allows BMC to switch (default) 2-3: BIOS2 (backup only, use when BIOS1 flash crashes)
JSEL_BMC1	 1	1-2: BMC1 (default) 2-3: BMC2
JBAT1	 1	1-2: Normal (default) 2-3: CMOS Clear
J1_1	 1	1-2: UID Button (default) 2-3: BMC Reset Button

Motherboard LEDs

LED1: BMC Heartbeat LED

This LED indicates the BMC (Baseboard Management Controller) status.

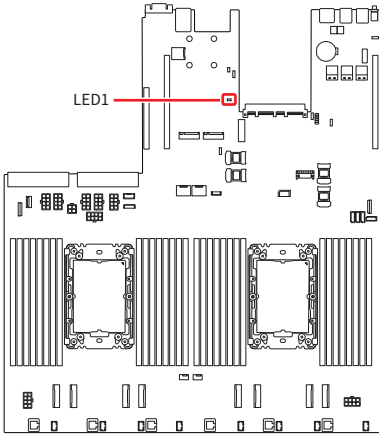

Status	Description
○ Off	BMC is not activated
● Blinking	BMC is functioning normally

LED_H1, LED_L1: Port 80 Debug LEDs

The Port 80 debug LEDs display progress and error codes during and after POST (Power-On Self Test).

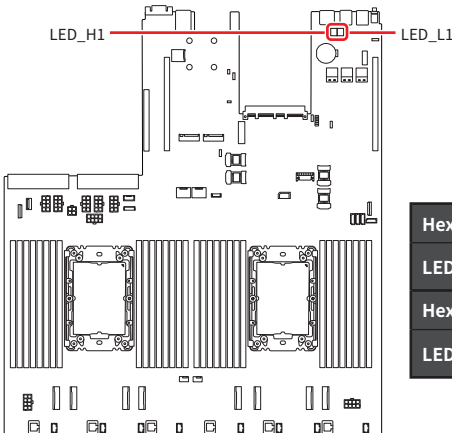

Hexadecimal Character Table

Hexadecimal	0	1	2	3	4	5	6	7
LED display	0	1	2	3	4	5	6	7
Hexadecimal	8	9	A	B	C	D	E	F
LED display	8	9	A	b	C	d	E	F

Getting Started

Important

- All information is subject to change without prior notice.
- The system photos are provided for demonstration purposes only. The appearance and internal view of your system may vary depending on the model you purchased.

Necessary Tools



Screwdriver



Pliers



Tweezers



Anti-Static Gloves

Safety Precautions

The following precautions should be observed while handling the system:

- Place the system on a flat and stable surface.
- Do not place the system in environments subject to mist, smoke, vibration, excessive dust, salty or greasy air, or other corrosive gases and fumes.
- Do not drop or jolt the system.
- Do not use a power adapter other than the one enclosed with the system.
- Disconnect the power cord before performing any installation procedures on the system.
- Do not perform any maintenance with wet hands.
- Prevent foreign substances, such as water, other liquids or chemicals, from entering the system while performing installation procedures.
- Use a grounded wrist strap before handling system components such as CPU, Memory, HDD, expansion cards, etc.
- Place system components on a grounded anti-static pad or on the bed that came with the components whenever the components are separated from the system.

System Setup

Important

Before removing or installing any components, make sure the system is not turned on or connected to the power.

Drive Bay

Installing 2.5" HDD/ SSD

1. Press the tray button to release the lever.
2. Pull the HDD/ SSD assembly out of the drive bay.
3. Insert the HDD/ SSD horizontally.

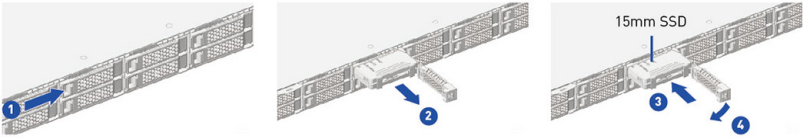

- The interposer BKT act as dummy HDD/ SSD when no drive inside.
- The interposer BKT act as spacer to support 7mm HDD/ SSD.

System Cover

Removing System Cover

1. Remove the **screws** securing the system on both sides.
2. To remove the top cover panels, press down on the **release latches** on both sides and then slide them to the front or back side of the system.

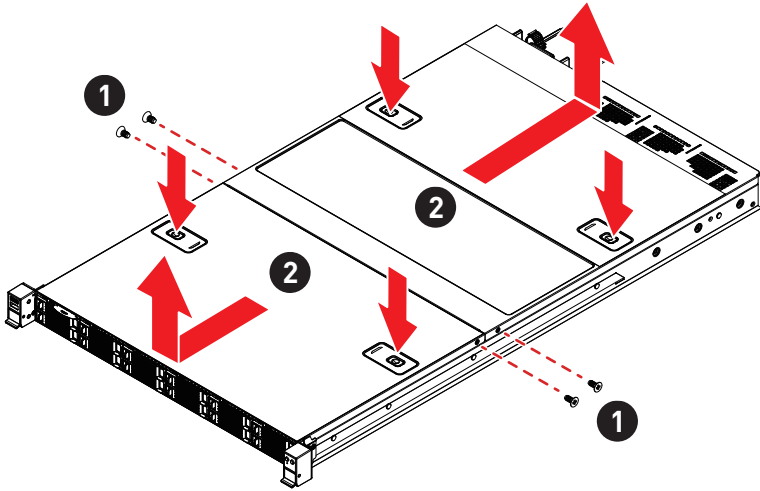

CPU & Heatsink

Use appropriate ground straps, gloves and ESD mats to protect yourself from electrostatic discharge (ESD) while installing the processor.

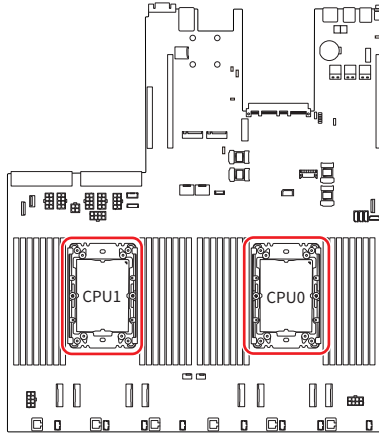

Important

- While **replacing the CPU**, always turn off the power supply or unplug the power supply's power cord from the grounded outlet first to ensure the safety of CPU.
- **Overheating** will seriously damage the CPU and system. Always make sure the cooling fan can work properly to protect the CPU from overheating. Make sure to apply an even layer of thermal paste (or thermal tape) between the CPU and the heatsink to enhance heat dissipation.
- Please check the instruction that come with your heatsink and thermal paste for more details before starting.

Assembly Overview

Important

Images are for illustration purposes only; actual parts may vary.

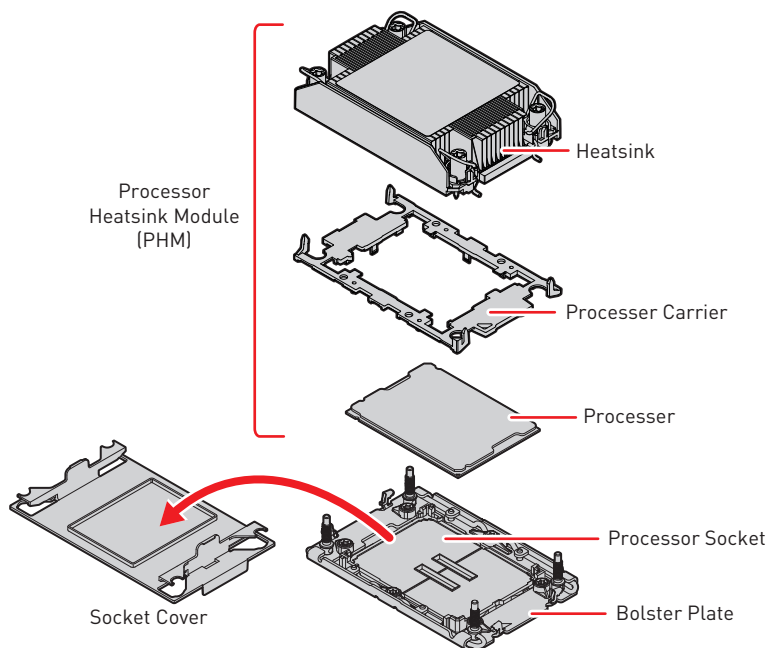

Important

- Confirm if your heatsink is firmly installed before turning on your system.
- Whenever CPU is not installed, always protect your CPU socket pins with the plastic cap covered.
- Do not touch the CPU socket pins to avoid damage.
- Read the CPU status in BIOS.

Installing CPU & Heatsink

- Place the processor carrier on top of the processor in the tray with their **pin 1 indicators aligned**. If installed properly, the CPU will snap into the carrier's side latches and the carrier will latch firmly to it.

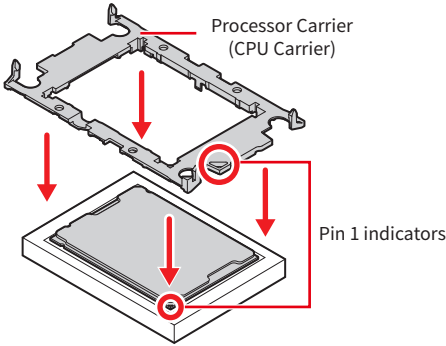

Important

Please refer to the following table for the corresponding CPU carrier.

CPU Package Type	CPU Carrier Code
Sapphire Rapids- SP XCC Emerald Rapids- SP XCC	E1A
Sapphire Rapids- SP MCC Emerald Rapids- SP MCC Sapphire Rapids EE	E1B
Sapphire Rapids + HBM	E1C

- Remove the **protective film** at the bottom of the heatsink if any.
 - To avoid damaging the fins of the heatsink, always grip the heatsink along the axis of the fins. Holding a heatsink along the side might damage its fins or solder.
- Make sure the heatsink has pre-applied thermal paste. If there isn't, you'll need to apply thermal paste to the bottom center of the heatsink.

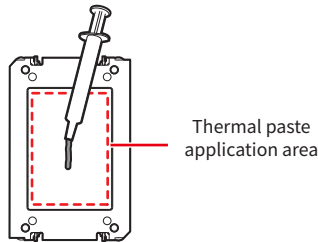

- Check the heatsink for a diagonally cut corner or the #1clip on the heatsink label if present. Align the **processor Carrier's Pin 1 indicator** with the **heatsink's cut corner (#1 clip)**, then gently press the heatsink down to engage the carrier's latching mechanism to the heatsink at four corners.

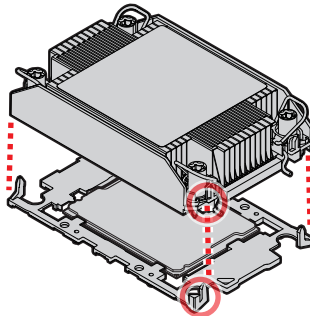

5. Make sure the attached clips on the carrier grab onto the heatsink and firmly secure the carrier, CPU and heatsink as one **Processor Heatsink Module (PHM)**.
6. Remove the socket cover by squeezing the finger grips in, then flip **4 anti-tilt wires** on the heatsink to the **unlocked position (inward)** and place the PHM on top of the bolster plate with the Pin 1 indicators aligned. Hold the PHM horizontally, carefully lower down to engage PHM to bolster the plate's alignment pin.

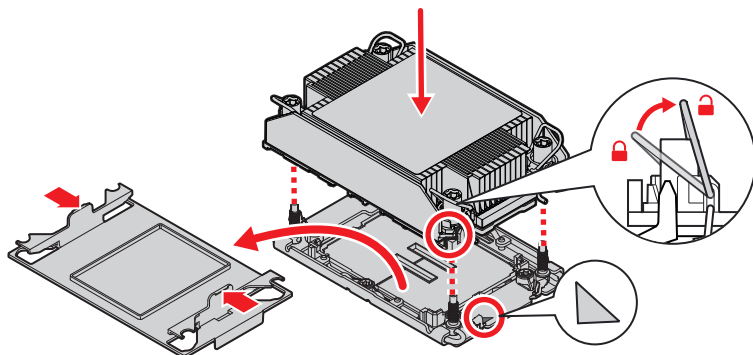

7. Flip 4 anti-tilt wires to the **locked position (outward)** and make sure the latches of the wires are firmly secure.

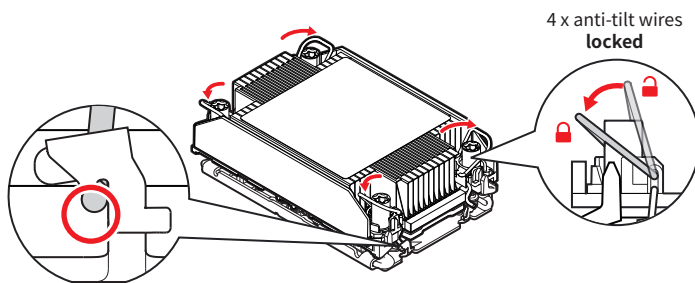

8. Tighten all screws on the PHM in diagonal sequences to secure the PHM to the motherboard. (Torque: $0.904 \text{ N} \cdot \text{m}$, $0.904 \text{ N} \cdot \text{m} = 9.2208 \text{ kgf} \cdot \text{cm} = 8 \text{ lbf} \cdot \text{in}$)
- To avoid distributing uneven pressure on the CPU, it is recommended to secure the PHM in two steps: first, loosely attach the screws at four points and then gradually tighten them.

Memory

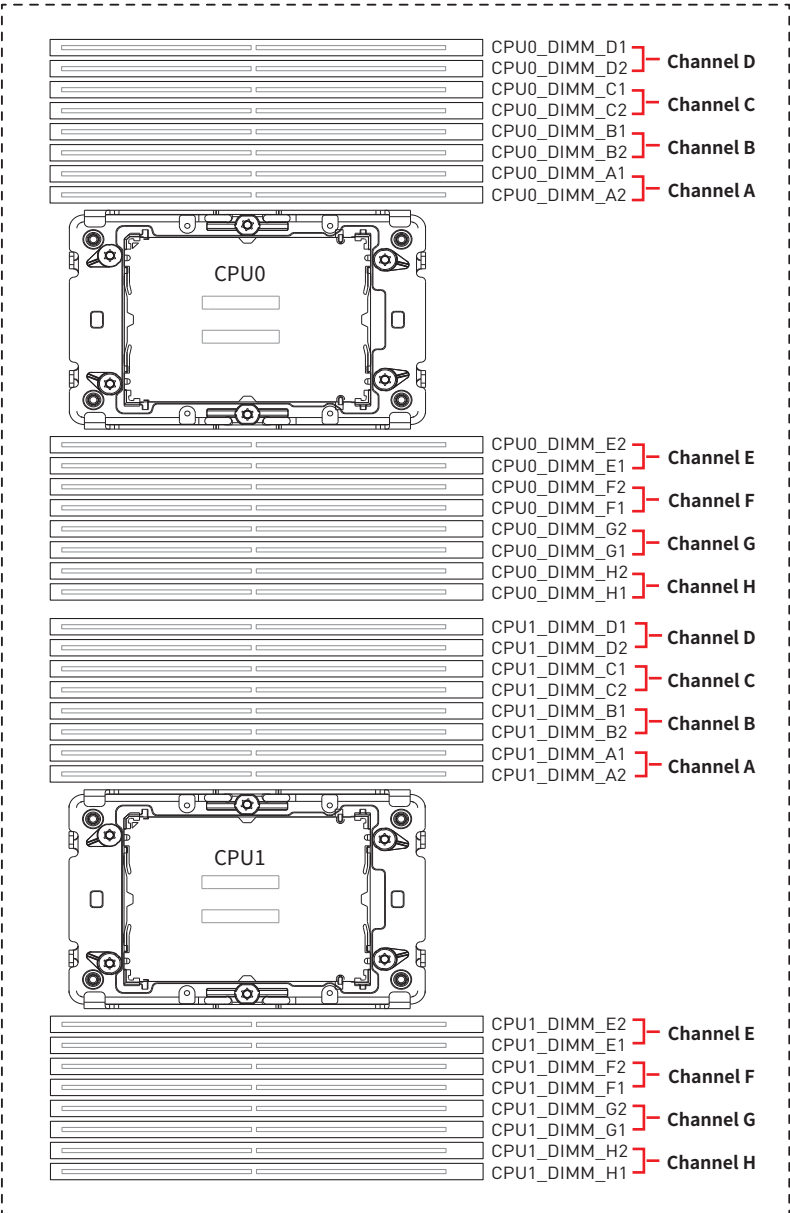

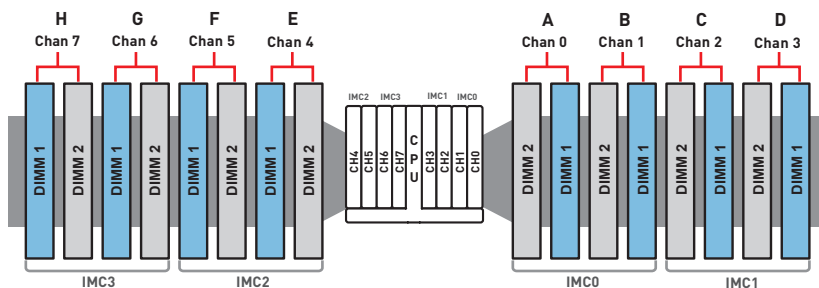

Recommended Memory Population

Key Parameters for DIMM Configurations

Parameter	Possible Values		
# of Channels Per Socket	1, 2, 4, 6, 8		
# of DIMMs Populated Per Channel	1DPC or 2DPC		
DIMM Type	RDIMM, 3DS RDIMM, 9x4 RDIMMs		
DIMM Construction	Non-3DS RDIMM Raw Cards	A	2Rx4
		C	1Rx4
		D	1Rx8
		E	2Rx8
	3DS RDIMM Raw Cards	A	4Rx4
			8Rx4
9x4 RDIMM Raw Cards	B	2Rx4	
	F	1Rx4	

DDR5 Only DIMM Configuration

SPR IMC#	IMC3				IMC2				IMC0				IMC1			
Channel	H		G		F		E		A	B		C		D		
	Chan 7		Chan 6		Chan 5		Chan 4		Chan 0	Chan 1		Chan 2		Chan 3		
DDR5	H1	H2	G1	G2	F1	F2	E1	E2	A2	A1	B2	B1	C2	C1	D2	D1
1+0								V								
											V					
					V											
2+0			V						V							
								V						V		
4+0			V					V						V		
									V					V		
6+0	V		V		V		V		V				V		V	
	V		V		V		V		V		V		V		V	
	V		V		V		V		V		V		V		V	
	V		V		V		V		V		V		V		V	
8+0	V		V		V		V		V		V		V		V	
	V		V	V	V		V	V	V		V	V	V		V	V
12+0	V	V	V	V	V	V	V	V	V	V	V	V	V	V	V	V
	V	V	V	V	V	V	V	V	V	V	V	V	V	V	V	V
16+0	V	V	V	V	V	V	V	V	V	V	V	V	V	V	V	V
	V	V	V	V	V	V	V	V	V	V	V	V	V	V	V	V

"V" indicates DIMMs are populated with **DDR5**.

Important

1. There should be at least one DDR5 DIMM per socket.
2. Interleaving way limitations: 3-way Channel and 3-Way Rank interleaving are not supported. A 2-Way + A 1-Way would be implemented instead of A 3-Way for those channel DIMM configurations. A 2-way interleave method is implemented across 3 ranks in a channel.
3. Sapphire Rapids processor erratum prevents using 6-way Hemisphere mode, 6-way All-to-All mode would be the default for 6 channel configurations.
4. If the system detects a DIMM fails at boot time, BIOS takes map-out actions for a fallback to the nearest reduced POR config in the table.
5. Rank sparing, ADDDC, channel mirroring, and Hemisphere/quad modes are not supported with SGX.
6. SPR+HBM does not support Hemisphere/SNC2 modes.
7. UMA default - see 6-DIMM configurations, x6 interleaving for All-to-All mode.

Installing Memory Modules

1. Open the side clips to unlock the DIMM slot.
2. Insert the DIMM vertically into the slot, ensuring that the off-center notch at the bottom aligns with the slot.
3. Push the DIMM firmly into the slot until it clicks and the side clips automatically close.
4. Verify that the side clips have securely locked the DIMM in place.

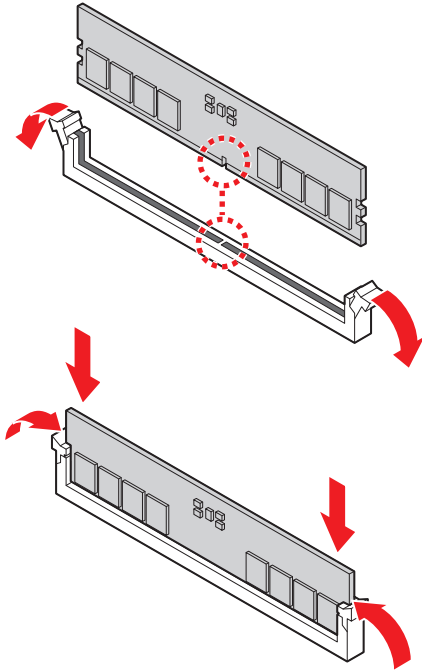

Important

You can barely see the golden finger if the memory module is properly inserted in the DIMM slot.

M.2 M Key

Installing M.2 M Key



Video Demonstration

Watch the video to learn how to Install M.2 SSD.



1. Loosen the M.2 riser screw from the motherboard.

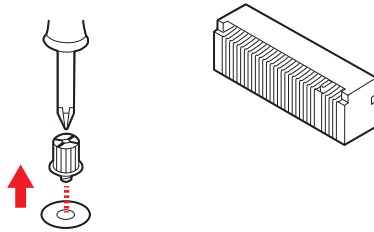

2. Move and fasten the M.2 riser screw to the appropriate location according your M.2 SSD size.

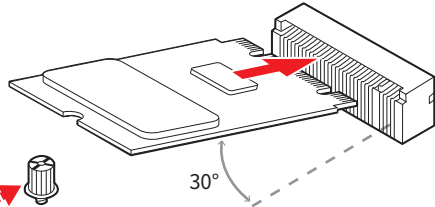

3. Insert your M.2 SSD into the M.2 slot at a 30-degree angle.

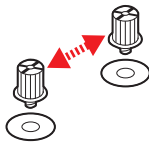

4. Secure the M.2 SSD in place with the supplied M.2 screw.

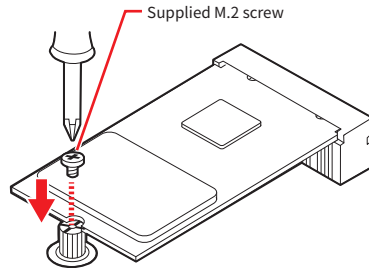

PCIe Add-in Card

Installing PCIe Add-in Card

1. Loosen the screws on the riser bracket to remove the filler panels.
2. Align the PCIe add-in card with the connector on the riser card, and insert it until it is fully seated.
3. Tighten the screws to securely fix the PCIe add-in card in place.

 **Important**

The procedure for installing PCIe add-in cards are the same for all riser slots.

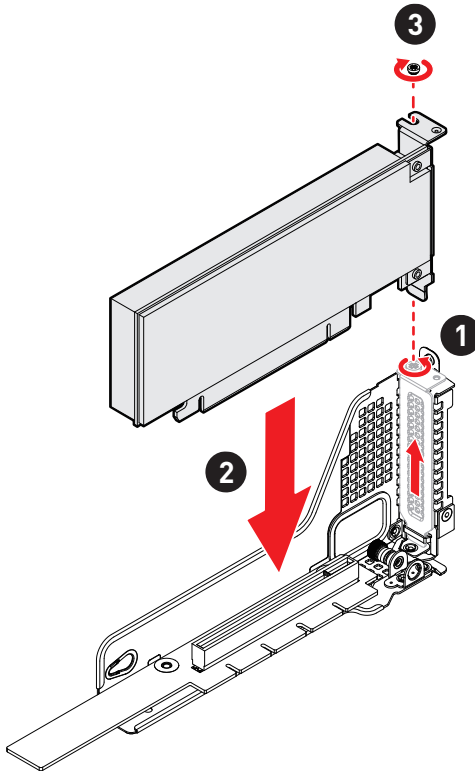

Installing Riser Card Assembly

1. Make sure the **key slots on the rear edge of the riser card** assembly are aligned with the **mounting pins on the rear edge of the system** (indicated by the red circle in the image below).
2. Insert the riser card assembly into the PCIe slot on the system board.
3. Tighten the screws on the rear side of the system to secure the riser card assembly.

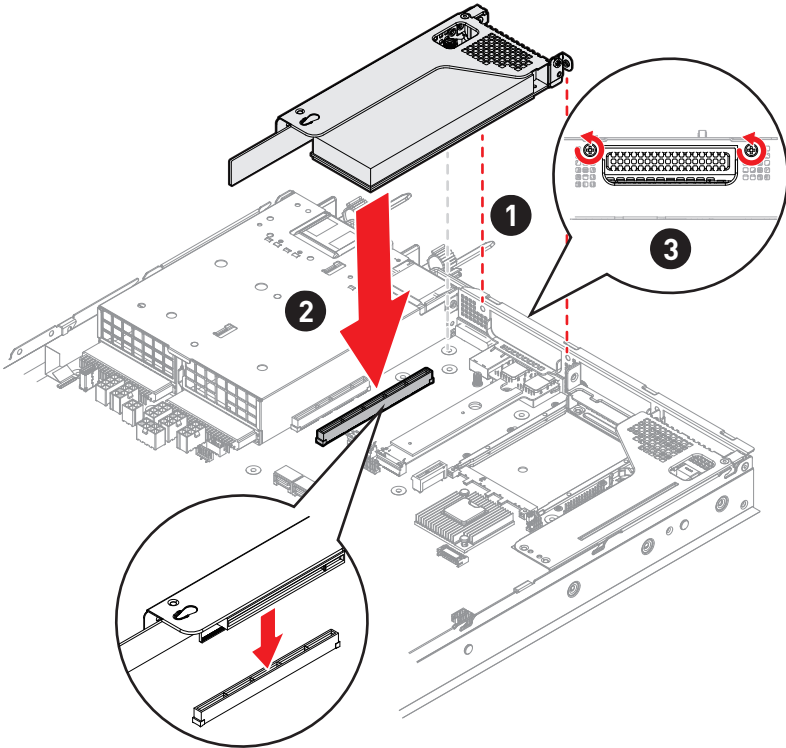

System Fan

The server system is equipped with **8 non-hot swappable system fans** that measure **40 x 40 x 56mm**, which provide primary airflow to maintain optimal cooling and prevent overheating.

The fan features include:

- Tachometer on each fan allows BMC to monitor the system's status in real-time.
- An integrated BMC firmware automatically adjusts fan speed based on the system's thermal status to maintain optimal performance.

Installing 1U Fan

1. Lower the system fan until it seated firmly.
 2. Connect the fan cable to the system board.
- *Note the fool-proof design on the connector before docking it.*

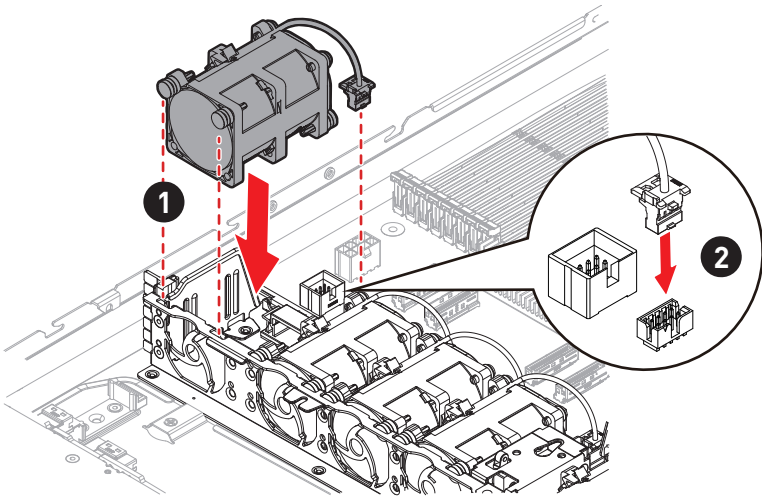

Power Supply Unit (PSU)

The server system supports two power supplies that can be easily inserted and removed from the rear side of the system without the need for tools.

Important

- Both power supplies must be identical and both power cords should be connected.
- Failing to connect both power supplies could result in CPU throttling.

Installing PSU

1. Remove the PSU blank.
2. Slide the PSU into the chassis bay until the release latch snaps into place.
3. Connect the power cable to the PSU power outlet.

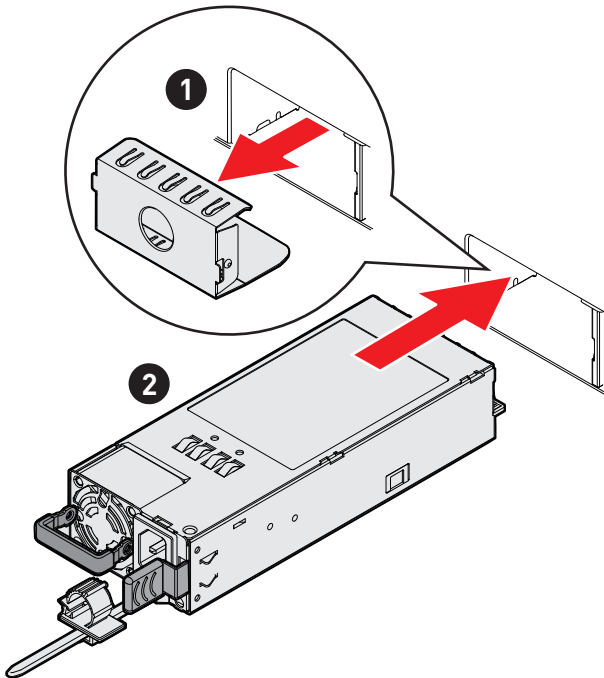

Cable Routing



Important

Please remove the **fan cage** before routing cables.

I2C Cable

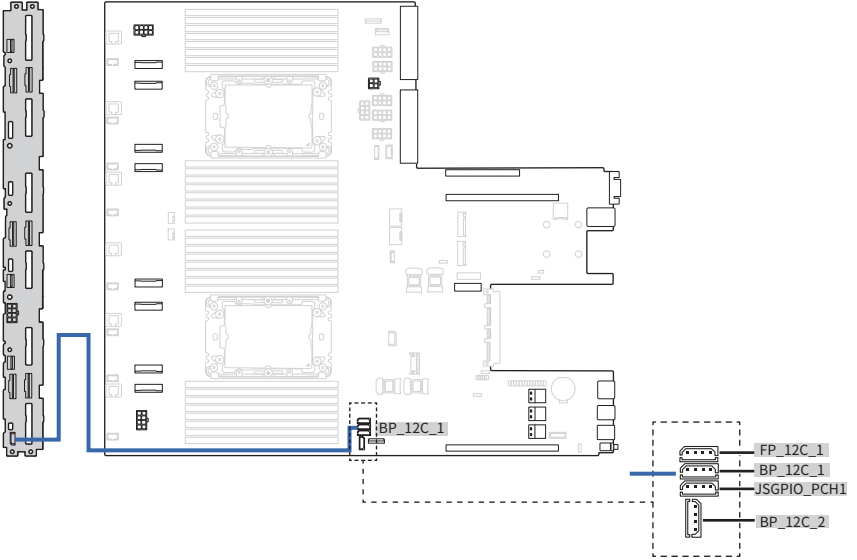

8-pin to 8-pin Power Cable

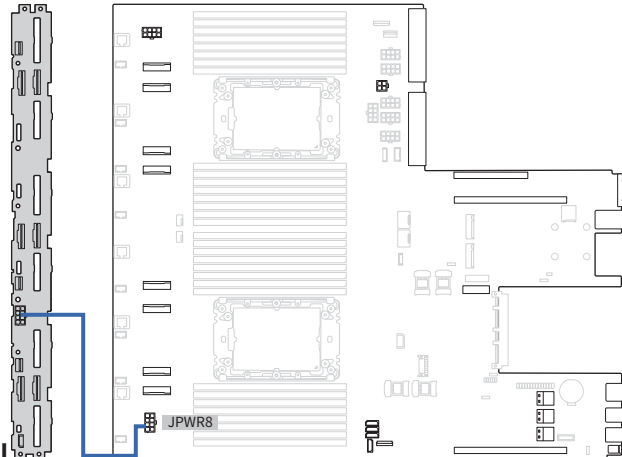

MCIO 8i to SlimlineSAS 8i Cable



SlimlineSAS 8i to SlimlineSAS 8i Cable

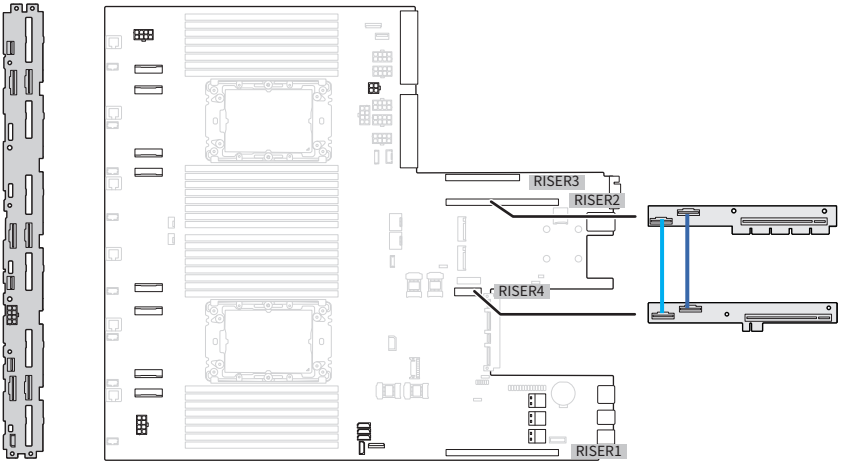

Slide Rail

Important

The pre-installed screws on the outer rail bracket are intended only for square rack holes. For round holes, please switch to the “7.1 round hole screw”.

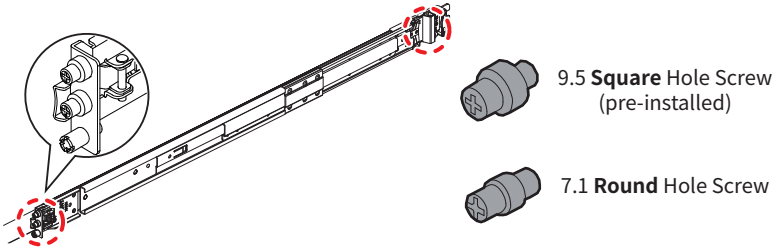

Disassembling Slide Rail

Slide the **release tab** forward to separate the inner rail from the bracket.

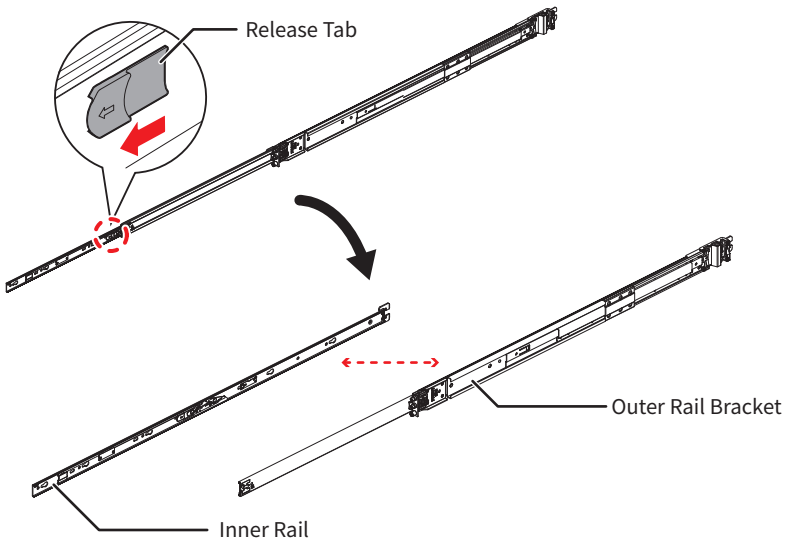

Installing Inner Rail to System

1. Align the standoffs on the side of the system with the hole on the inner rail, then **pull the inner rail backwards** till it locks into place.
2. Tighten the screw to secure the inner rail.
3. Repeat the same procedure to install the inner rail on the other side of the system.

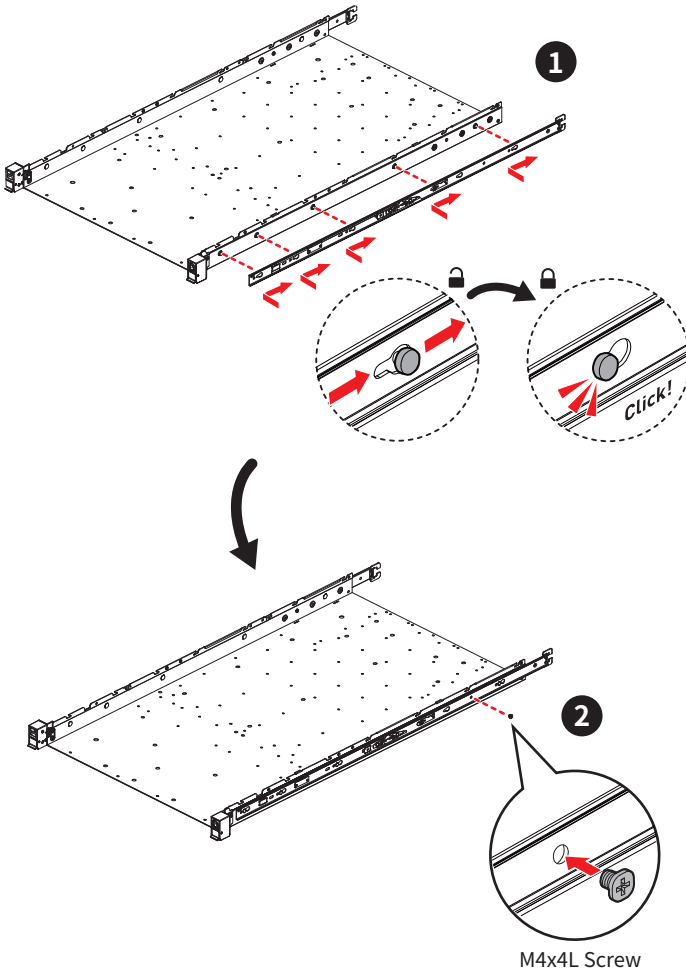

Retracting Outer Rail Bracket

Pull the latch downward to slide the middle rail back to the outer rail bracket.

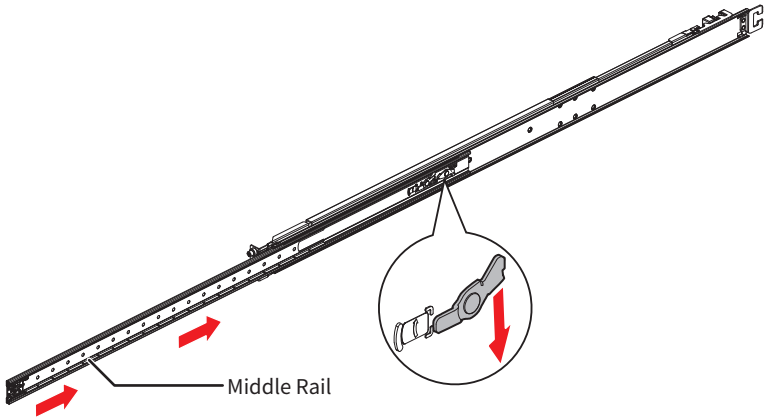

Attaching Outer Rail Bracket to Rack Frame

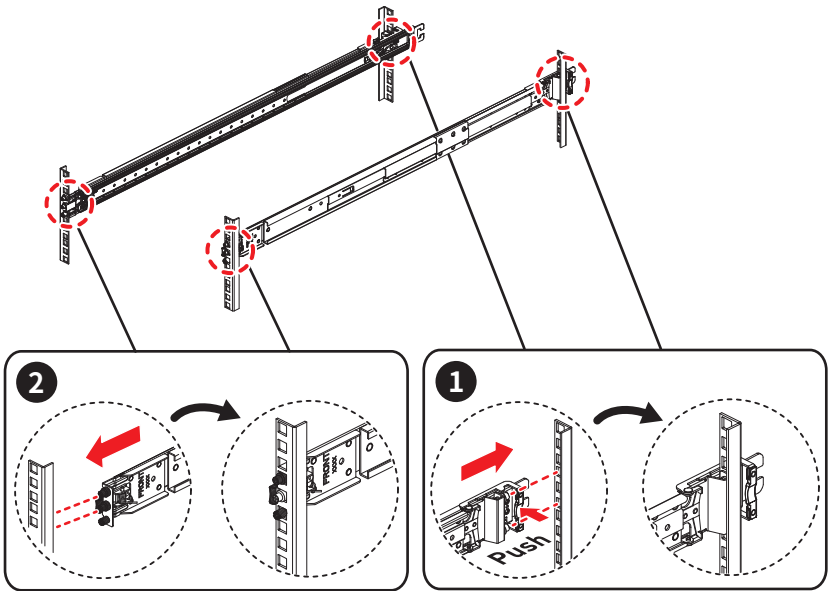

Installing System into Rack

1. Pull out the middle rails till it fully extended.
2. Engage the inner rails of the system to the middle rails, then push the system forward until it stops.
3. Push the system into the rack by sliding the **two-way release tabs** forward or backward.
4. Tighten the screws to secure the system.

Important

Ensure the ball bearing retainers are locked forward on each middle rail.

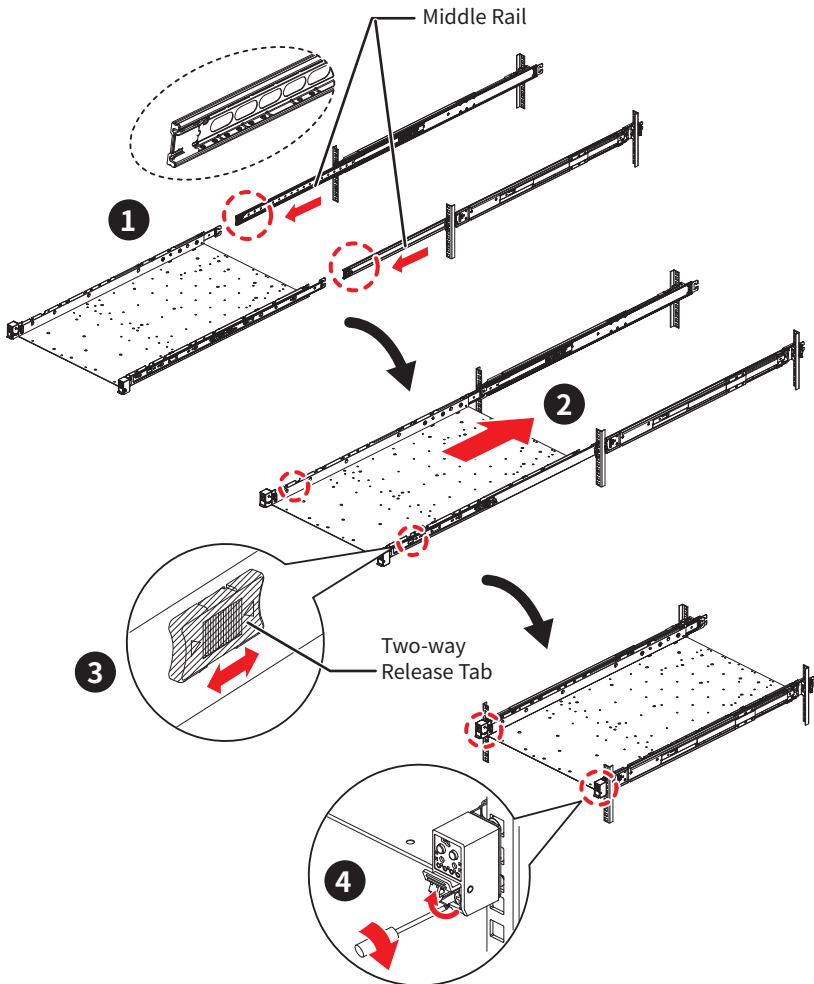

Detaching Outer Rail Bracket from Rack Frame

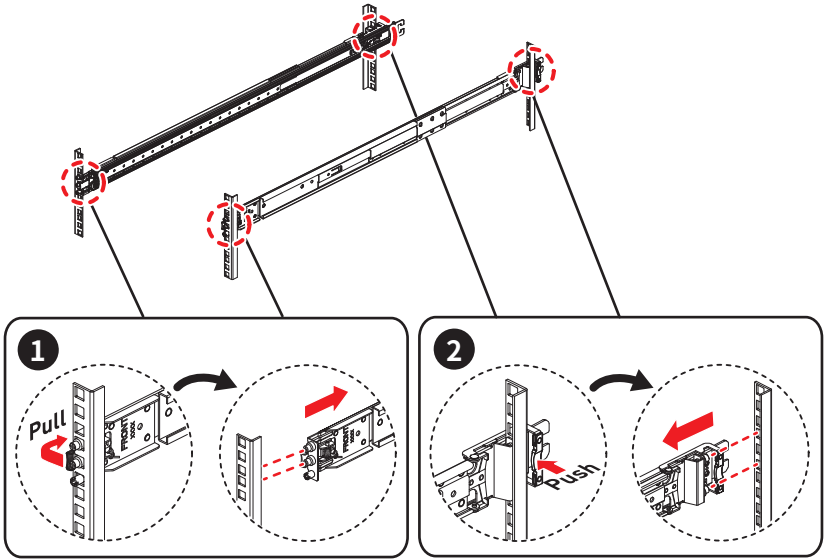

Detaching Inner Rail from System

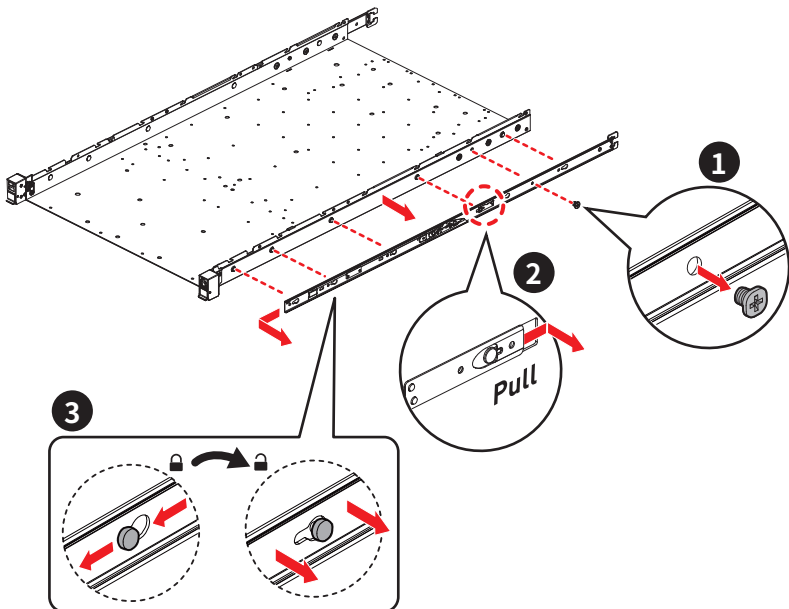



[MSI.COM](https://www.msi.com)



[EPS.MSI.COM](https://www.msi.com/eps)