



OPEN Industry Standard, Flexible Architecture

GREEN Less Heat, Less Power Consumption

STABLE Robust Design, Quality Parts

Stable and
Reliable Solution

Server/Workstation

Motherboard

4U8G-TURIN2

User Manual

English



Version 1.04

Published Jan. 2026

Copyright©2026 ASRock Rack Inc. All rights reserved.

Copyright Notice:

No part of this documentation may be reproduced, transcribed, transmitted, or translated in any language, in any form or by any means, except duplication of documentation by the purchaser for backup purpose, without written consent of ASRock Rack Inc.

Products and corporate names appearing in this documentation may or may not be registered trademarks or copyrights of their respective companies, and are used only for identification or explanation and to the owners' benefit, without intent to infringe.

Disclaimer:

Specifications and information contained in this documentation are furnished for informational use only and subject to change without notice, and should not be constructed as a commitment by ASRock Rack. ASRock Rack assumes no responsibility for any errors or omissions that may appear in this documentation.

With respect to the contents of this documentation, ASRock Rack does not provide warranty of any kind, either expressed or implied, including but not limited to the implied warranties or conditions of merchantability or fitness for a particular purpose.

In no event shall ASRock Rack, its directors, officers, employees, or agents be liable for any indirect, special, incidental, or consequential damages (including damages for loss of profits, loss of business, loss of data, interruption of business and the like), even if ASRock Rack has been advised of the possibility of such damages arising from any defect or error in the documentation or product.



This device complies with Part 15 of the FCC Rules. Operation is subject to the following two conditions:

- (1) this device may not cause harmful interference, and
- (2) this device must accept any interference received, including interference that may cause undesired operation.

CALIFORNIA, USA ONLY

The Lithium battery adopted on this server motherboard contains Perchlorate, a toxic substance controlled in Perchlorate Best Management Practices (BMP) regulations passed by the California Legislature. When you discard the Lithium battery in California, USA, please follow the related regulations in advance.

“Perchlorate Material-special handling may apply, see www.dtsc.ca.gov/hazardouswaste/perchlorate”

ASRock Rack’s Website: www.ASRockRack.com

Setting up the Server in a Restricted Access Location/Restricted Access Area

- Access can only be gained by service persons or by users who have been instructed about the reasons for the restrictions applied to the location and about any precautions that shall be taken.
- Access is through the use of a tool or lock and key, or other means of security, and is controlled by the authority responsible for the location.
- Leave enough clearance (25 inches in the front and 30 inches in the back of the rack) to allow the front door to be opened completely and to allow for sufficient airflow.
- This product is for installation merely in a Restricted Access Location.
- This product is not suitable for use with visual display work place devices according to §2 of the the German Ordinance for Work with Visual Display Units.
- Only skilled person and Instructed person can remove the chassis covers to access the inside of the system.

Replaceable Batteries

CAUTION

**RISK OF EXPLOSION IF BATTERY IS REPLACED BY AN INCORRECT TYPE.
DISPOSE OF USED BATTERIES ACCORDING TO THE INSTRUCTIONS**

Warning

When removal of the chassis lid required for servicing:

- Turn off power and unplug any power cords/cables, and
- Reinstall the chassis lid before restoring power.

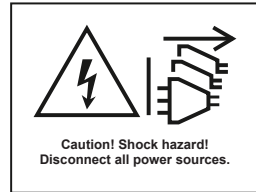

Important Safety Instructions

Pay close attention to the following safety instructions before performing any of the operation. Basic safety precautions should be followed to protect yourself from harm and the product from damage:

- Operation of the product should be carried out by suitably trained, qualified, and certified personnel only to avoid risk of injury from electrical shock or energy hazard.
- Disconnect the power cord from the wall outlet when installing or removing main system components, such as the server motherboard and power supply unit.
- Place the system on a stable and flat surface.
- Use extreme caution when working with high-voltage components.
- When handling parts, use a grounded wrist strap designed to prevent static discharge.
- Keep the area around the system clean and clutter-free.
- Keep all components and printed circuit boards (PCBs) in their antistatic bags when not in use.
- Handle a board by its edges only; do not touch its components, peripheral chips, memory modules or contacts.
- The power cord must be connected to a socket or outlet with a ground connection.

Contents

Chapter 1 Introduction	1
1.1 Shipping Box Contents	2
1.2 Specifications	3
Chapter 2 Server System Overview	6
2.1 System Components	6
2.2 Internal Features	7
2.3 System Front Panel	9
2.4 System Rear Panel	10
2.5 I/O Panel	11
2.6 LED	16
Chapter 3 Hardware Installation and Maintenance	18
3.1 Server Top Cover	19
3.2 Hard Drive	23
3.3 Power Supply	25
3.4 System Fan	27
3.5 Add-in Card	28
3.6 GPU Card	30
3.7 OCP Card	32
Chapter 4 Server Motherboard (TURIN2D24G-2L+/500W)	34
4.1 Layout	34
4.2 Block Diagram	38
4.3 Installing the CPU and Heatsink (LGA 6096 Socket)	39
4.4 Installing the Memory Modules (DIMM)	44
Appendix	45
Installing the Server in a Rack	45

Chapter 1 Introduction

Thank you for purchasing 4U8G-TURIN2, a reliable barebone system produced under ASRock Rack's consistently stringent quality control. It delivers excellent performance with robust design conforming to ASRock Rack's commitment to quality and endurance.

This guide provides the instructions of insertion and extraction of chassis components, such as chassis covers, system fans, power supplies, hard drive trays, and other main components this system supports. If the system is pre-installed a server motherboard, refer to the server motherboard user manual for the information of the server motherboard components, specifications and BIOS settings.

System	ASRock Rack Server Motherboard
4U8G-TURIN2	TURIN2D24G-2L+/500W



Because the hardware specifications might be updated, the content of this documentation will be subject to change without notice.



The illustrations shown in this manual are for reference purposes only and may not exactly match the model purchased.



If requiring technical support related to this system, please visit the website for specific information about the using model.
<http://www.asrockrack.com/support/>

1.1 Shipping Box Contents

Items	Quantity
Server Barebone: 4U8G-TURIN2 (with 8 12V-2x6 Cables)	1
CPU Heatsink	2
Rail Kit	1
Accessory Box	1
- 8 CPU 8-pin Cables	
- 8 PCIe 8-pin Cables	
- 4 Power Cords	
- 1 Quick Installation Guide	
- 2 Screw for M.2 Sockets	



If any items are missing or appear damaged, contact the authorized dealer.

1.2 Specifications

4U8G-TURIN2	
System	
Form Factor	4U Rackmount
Dimension	786 x 438 x 176.5mm (30.9" x 17.2" x 6.9")
Support MB	TURIN2D24G-2L+/500W
Front Panel	
Button	Power button w/ LED, reset button, NMI button, UID button w/ LED
LED	System fault LED, hard drive activity LED
I/O Port	2 RJ45 (1GbE) by Intel® i350, share with rear I/O 1 Dedicated IPMI, shares with rear I/O 4 Type-A (USB3.2 Gen1) 1 DB15 (VGA)
External Drive Bay / Storage	
Front Side Drive Bay	24 Hot-swap 2.5" drive bays: supports 4 NVMe (PCIe5.0 x4) drives supports additional SATA/SAS drives via RAID/HBA card
Front Side Backplane	24-port NVMe/SATA/SAS* passive backplane *SAS drive is only supported with additional RAID/HBA cards.
Internal Side	1 M-key (PCIe3.0 x4 or SATA 6Gb/s), supports 22110/2280 form factor [CPU0] 1 M-key (PCIe3.0 x4 or SATA 6Gb/s), supports 22110/2280 form factor [CPU1]
Power Supply	
Type	3+1 CRPS
Output Watt	1000W @ 100-127Vac input 2700W @ 200-240Vac input
Efficiency	80-PLUS Titanium
AC Input	Low-line: 100-127Vrms, 47/63Hz High-line: 200-240Vrms, 47/63Hz
System Fan	
Fan	5 Middle hot-swap 80x80mm fans

Processor System	
CPU	Supports AMD EPYC™ 9005/9004 (with AMD 3D V-Cache™ Technology) and 97x4 series processors
Socket	Dual socket SP5 (LGA 6096)
Thermal Design Power	Up to 500W
Chipset	System on Chip
System Memory	
Supported DIMM Quantity	12+12 DIMM slots (1DPC)
Supported Type	Supports DDR5 288-pin RDIMM, RDIMM-3DS
Max. Capacity per DIMM	RDIMM: 128GB (2Rx4) RDIMM-3DS: 256GB (2Rx4)
Max. DIMM Frequency	6400MHz
Voltage	1.1V
PCIe Expansion Slot	
PCIe x16	Rear: 8 FHFL dual-slot PCIe5.0 x16 (CPU direct link)
PCIe x8	Front: 1 FHHL PCIe5.0 x8
Ethernet	
Additional GbE Controller	Intel® i350: 2 RJ45 (1GbE)
OCP Slot	1 OCP NIC 3.0 (PCIe5.0 x8)
Server Management	
BMC Controller	ASPEED AST2600
IPMI Dedicated GLAN	1 Realtek RTL8211F for dedicated management GLAN
Graphics	
Controller	ASPEED AST2600
VRAM	DDR4 512MB

Rear I/O	
UID Button/ LED	1 UID button w/ LED
VGA Port	1 DB15 (VGA)
USB3.2 Gen1 Port	2 Type-A (USB3.2 Gen1)
RJ45	2 RJ45 (1GbE) by Intel® i350, share with front panel 1 Dedicated IPMI, shares with front panel
System BIOS	
BIOS Type	AMI UEFI BIOS; 256Mb (32MB) SPI Flash ROM
BIOS Feature	ASRock Rack Instant Flash, ACPI 6.4 and above compliance wake up events, SMBIOS 3.5.0 and above, Plug and Play (PnP)
Hardware Monitor	
Temperature	CPU, MB, card side temperature sensing
Fan	Fan tachometer CPU quiet fan (allows chassis fan speed auto-adjust by CPU temperature) Fan multi-speed control
Voltage	P0_VDDCR_CPU0, P0_VDDCR_CPU1, P0_VDDCR_SOC, P0_VDD_18_DUAL, P0_VDD_11_S3, P0_VDDIO, P1_VDDCR_CPU0, P1_VDDCR_CPU1, P1_VDDCR_SOC, P1_VDD_18_DUAL, P1_VDD_11_S3, P1_VDDIO, +BAT, +12V, +3VSB, +5VSB
Environment	
Temperature	Operation temperature: 10°C ~ 35°C Non operation temperature: -40°C ~ 70°C
Humidity	Non operation humidity: 20% ~ 90% (non condensing)



The functions are supported depending on the type of the server motherboard. Refer to the server motherboard manual for more information.

Chapter 2 Server System Overview

This chapter provides diagrams showing the location of important components of the server system.

2.1 System Components

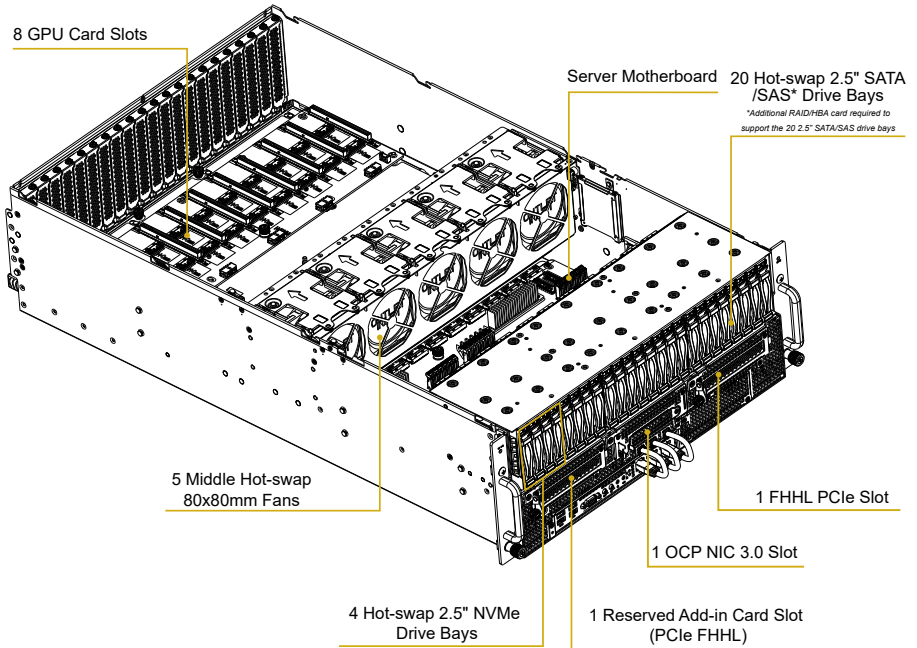

2.2 Internal Features

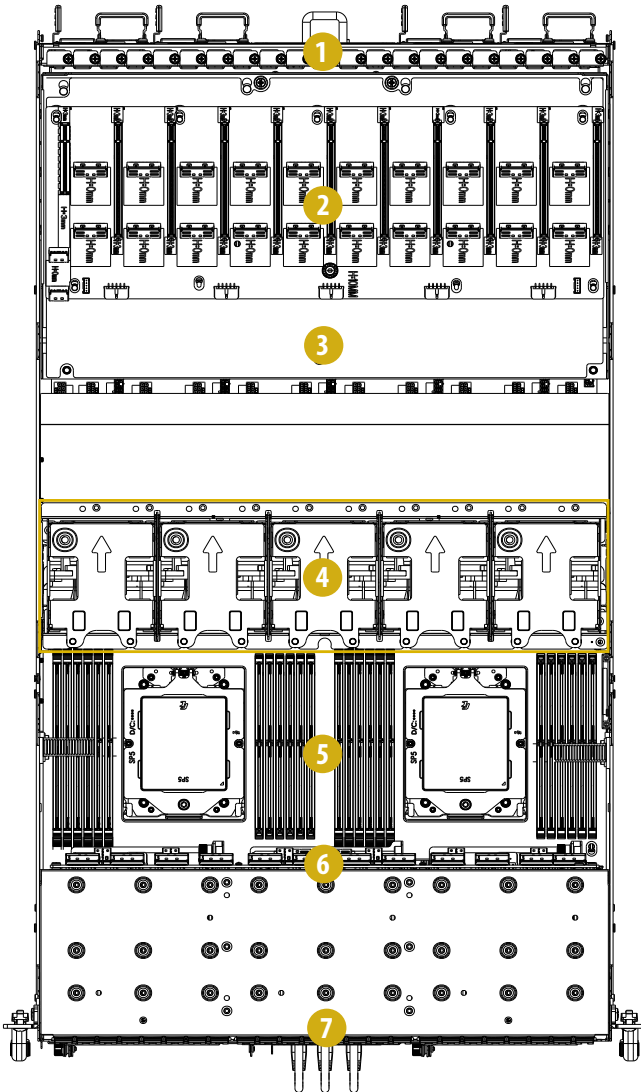

No.	Description
1	<p>Top: 8 FHFL dual-slot PCIe5.0 x16 slots (CPU direct link)</p> <p>Bottom: 3+1 CRPS Rear I/O panel</p>
2	Switch board (SWB)
3	Power distribution board (PDB)
4	5 Middle hot-swap 80x80mm fans (left-to-right: FAN1 ~ FAN5)
5	Server motherboard (MB)
6	Hard drive backplane board (BPB)
7	<p>Top: 24 Hot-swap 2.5" drive bays</p> <p>Middle: 1 Reserved add-in card slot (PCIe FHHL) 1 OCP NIC 3.0 (PCIe5.0 x8) slot [CPU0] 1 FHHL PCIe5.0 x8 slot</p> <p>Bottom: Front I/O panel</p>

2.3 System Front Panel

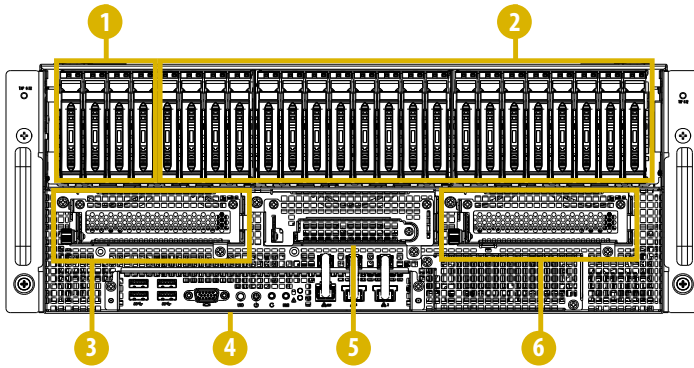

No.	Description
1	4 Hot-swap 2.5" NVMe (PCIe5.0 x4) drive bays [CPU1] Left-to-right: HDD1 ~ HDD4
2	20 Hot-swap 2.5" SATA/SAS* drive byas <i>*Additional RAID/HBA card required to support the 20 2.5" SATA/SAS drive bays</i> Left-to-right: HDD5 ~ HDD24
3	1 Reserved add-in card slot (PCIe FHHL)
4	Front I/O panel (depends on the specification of the server motherboard)
5	1 OCP NIC 3.0 (PCIe5.0 x8) slot [CPU0]
6	1 FHHL PCIe5.0 x8 slot [CPU0]

2.4 System Rear Panel

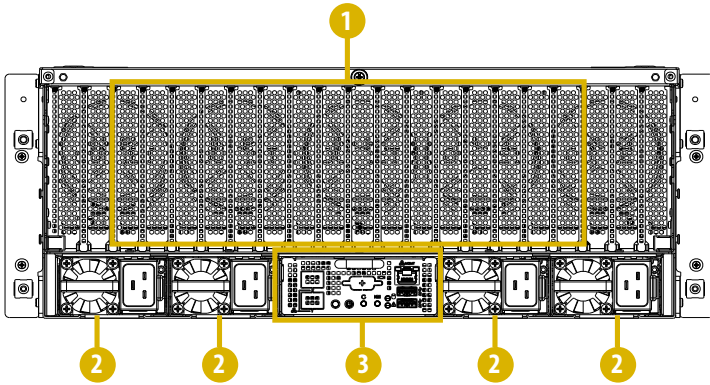

No.	Description
1	8 FHFL dual-slot PCIe5.0 x16 slots (CPU direct link) Left-to-right: PCIE1 ~ PCIE8
2	3+1 CRPS Left-to-right: PSU4 ~ PSU1
3	Rear I/O panel

2.5 I/O Panel

Front I/O Panel

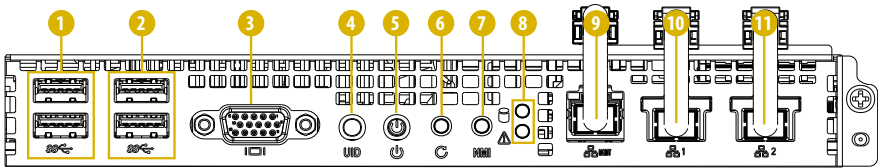

No.	Description
1	2 Type-A (USB3.2 Gen1) ports
2	2 Type-A (USB3.2 Gen1) ports
3	1 DB15 (VGA) port
4	1 UID button w/ LED
5	1 Power button w/ LED
6	1 Reset button
7	1 NMI button
8	Top: 1 Hard drive activity LED Bottom: 1 System fault LED
9	1 Dedicated IPMI LAN port, shares with rear I/O panel
10	1 RJ45 (1GbE) LAN port (LAN1), shares with rear I/O panel
11	1 RJ45 (1GbE) LAN port (LAN2), shares with rear I/O panel

Rear I/O Panel

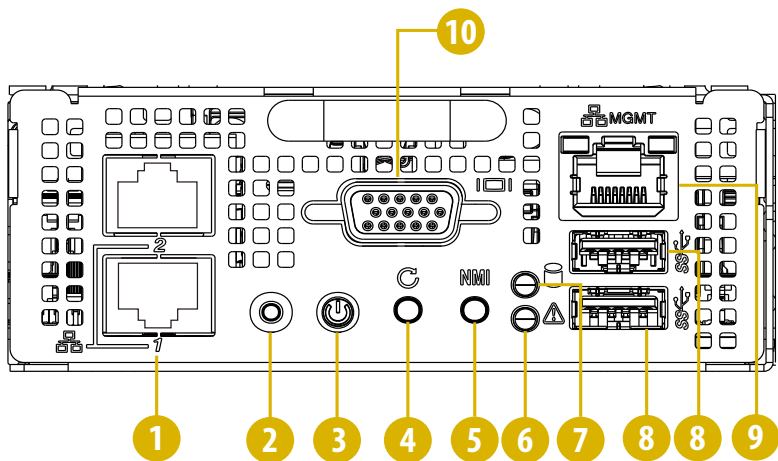

No.	Description
1	2 RJ45 (1GbE) LAN ports by Intel® i350, share with front I/O panel
2	1 UID button w/ LED
3	1 Power button w/ LED
4	1 System reset button
5	1 NMI button
6	1 System fault LED
7	1 Hard drive activity LED
8	2 Type-A (USB3.2 Gen1) ports
9	1 Dedicated IPMI LAN port, shares with front I/O panel
10	1 DB15 (VGA) port

UID Button

Press the UID button to toggle the front and rear UID LEDs on and off. Use this button to locate the server working on behind a rack of servers.

Power Button

Press the power switch button to toggle the system power on and standby/sleep modes. To remove all power from the system completely, disconnect the power cord from the server.

System Reset Button

When the system is completely unresponsive, press the system reset button to reboot the server without shutting it off and initialize the system.

NMI (Nonmaskable Interrupt) Button

Press the NMI button with a paper clip or pin to generate a nonmaskable interrupt and to put the server in a halt state for examination.

Status LED Definitions

UID LED	
Status	Description
Off	System identification is disabled.
Blue	System identification is active.

Power LED	
Status	Description
Off	Power off
Green	Power on

Hard Drive Tray Activity LED	
Status	Description
Off	Hard drive tray idle
Blinking Green	Hard drive tray access

System Fault LED	
Status	Description
Off	Running or normal operation
Red	At least one sensor has critical alert.

Front Dedicated IPMI LAN Port

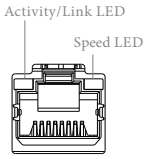

Dedicated IPMI LAN Port

Rear Dedicated IPMI LAN Port

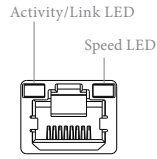

Dedicated IPMI LAN Port

Activity / Link LED	
Status	Description
Off	No link
Blinking Yellow	Data activity
On	Link

Speed LED	
Status	Description
Off	10Mbps connection or no link
Orange	100Mbps connection
Green	1Gbps connection

Front RJ45 (1GbE) LAN Port

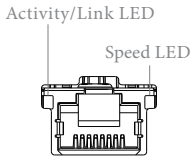

RJ45 (1GbE) LAN Port

Activity/Link LED	
Status	Description
Off	No link
Blinking Yellow	Data activity
On	Link

Speed LED	
Status	Description
Off	10Mbps connection or no link
Orange	100Mbps connection
Green	1Gbps connection

Rear RJ45 (1GbE) LAN Port

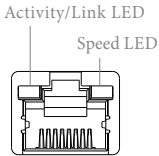

RJ45 (1GbE) LAN Port

Activity/Link LED	
Status	Description
Off	No link
Blinking Yellow	Data activity
On	Link

Speed LED	
Status	Description
Off	10Mbps connection or no link
Green	100Mbps connection
Orange	1Gbps connection

2.6 LED

PSU LED

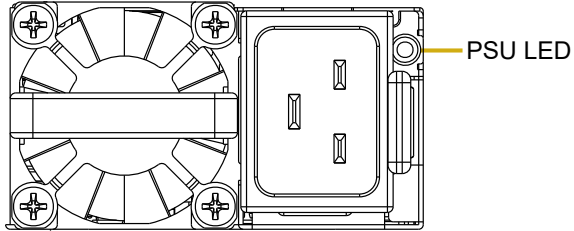

PSU LED	
Status	Description
Green	Normal work; output ON and OK
Blinking Green (0.5Hz)	AC Present Only 12VSB on (PS off) or PSU in Smart Redundant state
Amber	Module fault/protection in operating mode (failure, OCP, OVP, Fan Fail, OTP, UVP) AC cord unplugged
Blinking Amber (0.5Hz)	Warning (high temp, high power, high current, slow fan)

Drive Tray LED

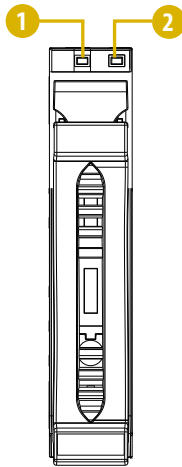

No.	Description
1	Drive tray power LED
2	Drive tray activity LED

Status LED Definitions

Drive Tray Power LED	
Status	Description
Off	No power to drive tray
Blue	Drive tray powered-on

Drive Tray Activity LED	
Status	Description
Off	Drive tray powered-off
Green	Drive tray active
Blinking Green	Drive tray accessing or reading
Red	Drive tray failed

Chapter 3 Hardware Installation and Maintenance

This chapter helps user assemble the chassis and install components.

Before You Begin

Before working with the server, pay close attention to the “Important Safety Instructions” at the beginning of this manual.



1. Ensure the motherboard battery is installed before unplugging the power cord or installing/removing the motherboard.
2. Before installing or removing any component, ensure that the power supply is off or the power cord is detached from the power supply. Failure to do so may cause severe damage to the motherboard, peripherals, and/or components.

1. Make sure the server is powered off.

Power down the server if it is still running.

- (1) Press the Power button to power off the server from full-power mode to standby-power (sleep) mode. The Power LED at the front turns from solid green to blinking green.
- (2) Disconnect the power cord first from the AC outlet and then from the server.
The power LED turns off.



The server is not completely powered down when pressing the Power button on the front panel. The Power button lets the server toggle between Power On and Standby (Sleep) modes. Some internal circuitry remain active in the Standby mode. To remove all power from the system completely, be sure to disconnect the power cord from the server.

2. Ensure having a clean and stable working environment. Avoid dust and dirt because contaminants may cause malfunctions.
3. Ground properly before touching any system component. A discharge of static electricity may damage components. Wear a grounded wrist strap if available.



1. Some components are already pre-installed. Simply properly connect the required cables before or after installation.
2. Refer to the server motherboard user manual for instructions on how to install server motherboard components.

3.1 Server Top Cover

Removing the Server Top Rear Cover



1. Before removing the top covers, power off the server and unplug the power cord.
2. The system must be operated with all the chassis top covers installed to ensure proper cooling.

1. Remove the screw securing the top rear cover to the chassis.
2. Hand-release the thumbscrew on the rear side of the chassis.
3. Press the tabs and push straight REAR to release the cover from the locked position. Lift up and remove the cover.

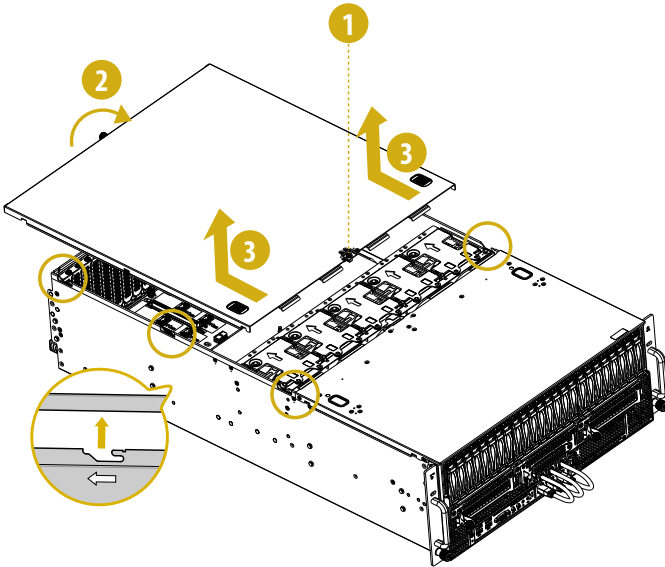

Removing the Server Top Front Cover

1. Remove the screw securing the top front cover to the chassis.
2. Push straight FRONT to release the cover from the locked position. Lift up and remove the cover.

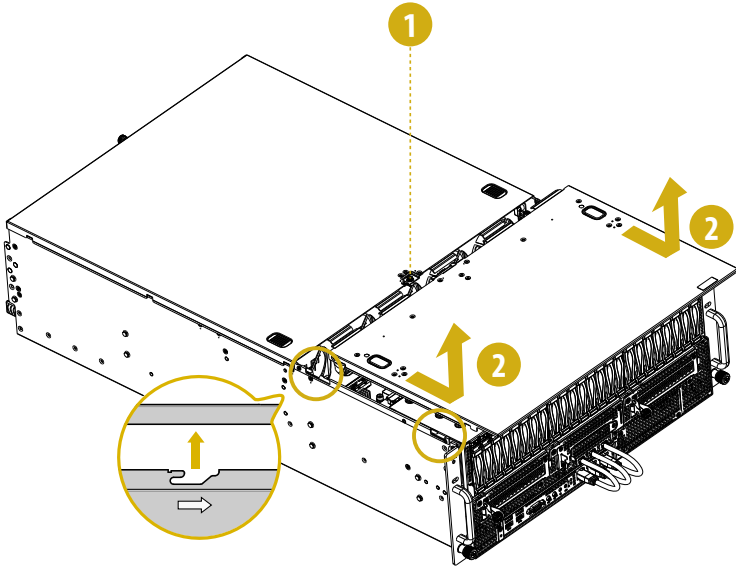

Installing the Server Top Front Cover

1. Lower the top front cover on the chassis, making sure the side latches align with the cutouts. Slide the cover toward the REAR of the chassis.
2. Secure the cover with the screw.

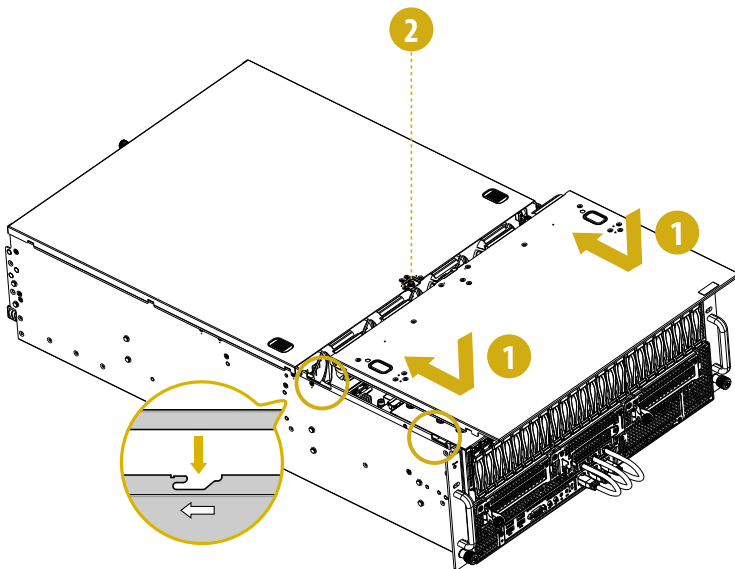

Installing the Server Top Rear Cover

1. Lower the top rear cover on the chassis, making sure the side latches align with the cutouts. Slide the cover toward the FRONT of the chassis.
2. Hand-tighten the thumbscrew on the rear side of the chassis.
3. Secure the cover in place with the screw.

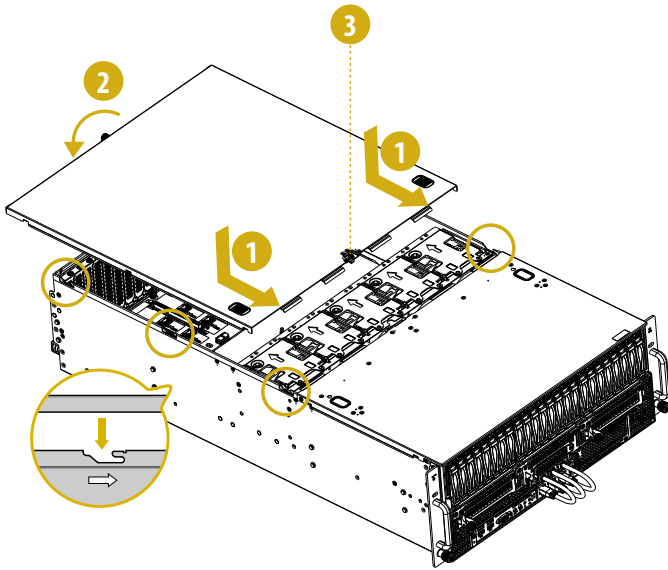

3.2 Hard Drive

The system supports hot-swap 2.5" hard drives. The hard drive bays are located on the front of the chassis.

Removing Hard Drive Tray from the Chassis

1. Press the locking lever latch on the hard drive tray to unlock the retention lever.
2. Rotate the lever out and away from the module bay and pull the tray out of the chassis.

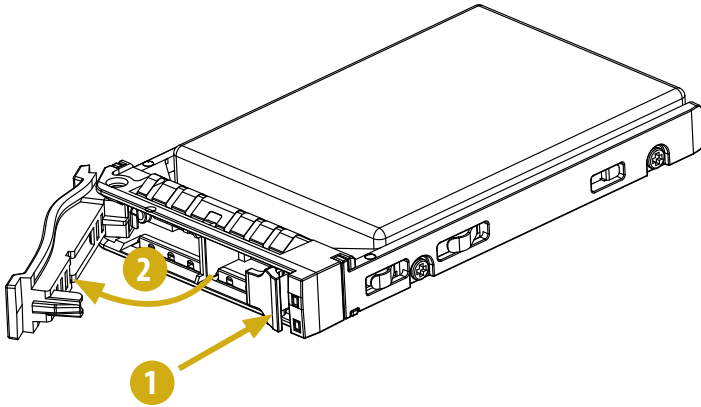

Installing Hard Drive to the Chassis

1. Engage two embossed pins into the side dimples on the hard drive tray.
2. Carefully push down the other side of hard drive until the other two embossed pins and side dimples lock into place.
3. Slide the hard drive assembly into the hard drive bay until the assembly is fully seated.
4. Push in the locking lever to lock the assembly in place.

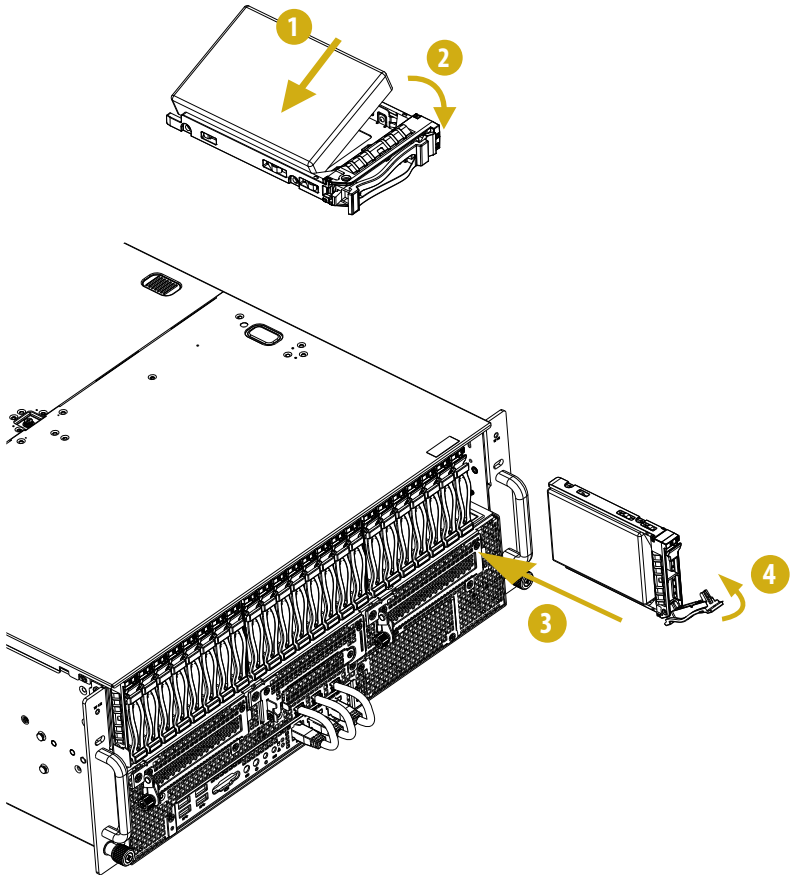

3.3 Power Supply

The system can accommodate 4 power supply units in the bay at the rear of the chassis. Each unit provides up to 2700W of power. 3 PSUs are required for full load operation, with the fourth PSU purely as a redundant, load-sharing backup. 1 PSU can be removed without affecting system operation.



1. Before replacing the power supply unit, power off the server, unplug the power cord, and disconnect all wiring from the power supply.
2. In a redundant system, it does not need to power down the server.

Removing the Power Supply Unit

To remove a failed power supply unit, identify the failed PSU by checking the power supply LEDs on the PSUs.

1. Hold onto the power supply handle while pressing the locking lever towards the power supply handle.
2. Pull to remove the PSU from the chassis.

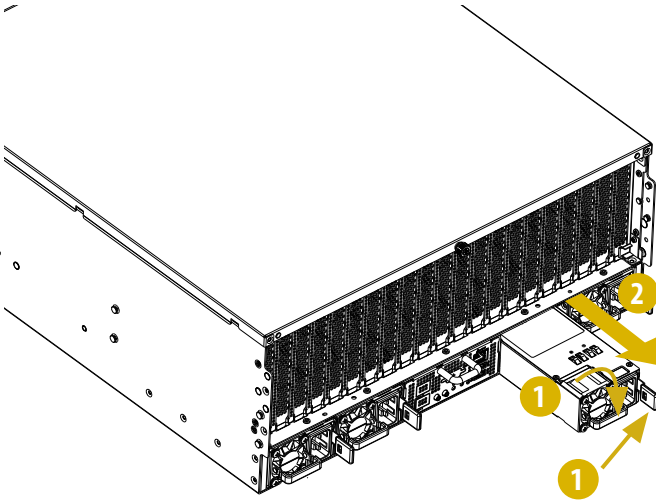

Installing the Power Supply Unit

Align the power supply unit with the power supply bay. Ensure the LED appears on the upper right when installing the PSU.

1. Carefully slide the PSU all the way into the power supply bay.
2. Make sure the PSU clicks in place and is well installed.

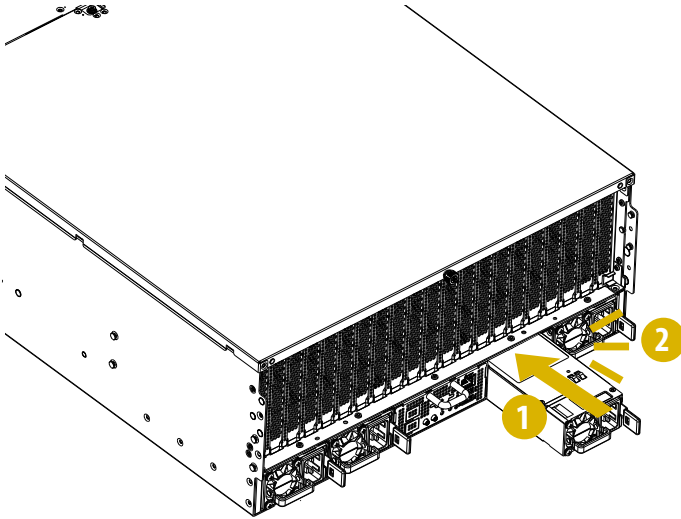

3.4 System Fan

The system supports five middle hot-swap 80x80mm system fans.

Replacing the System Fan

1. Lift to remove the failed fan.
2. Align the mounting holes on the replacement fan corners with the fan mounts on the fan bracket.
3. Make sure the arrow on the fan pointed to the REAR of the chassis.
4. Gently place the fan onto the mounts.
5. Make sure the fan is well seated.

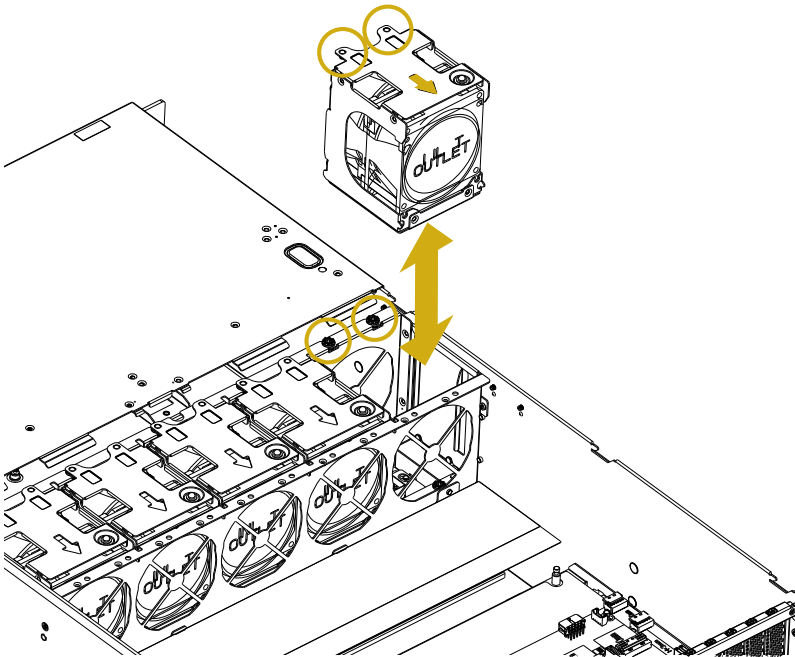

3.5 Add-in Card

Removing the PCIe Riser-card Tray from the Chassis

1. Remove the screws securing the hard drive frame to the chassis.
2. Lift up and remove the frame.
3. Remove the screws on the riser-card tray.
4. Pull to remove the tray from the chassis.

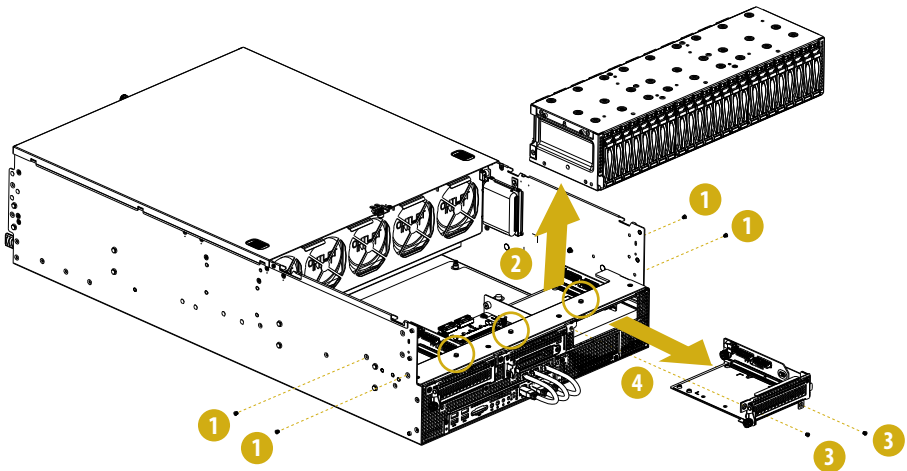

Installing the PCIe Add-in Card to the Chassis

1. Hand-release the thumbscrew securing the blanking plate to the tray. Pull up the latch.
2. Slide the blanking plate out sideways.

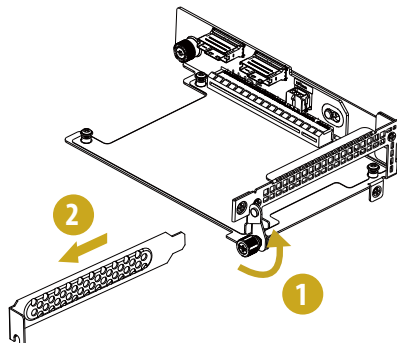

3. Place a PCIe add-in card in the tray. Make sure the add-in card is correctly seated.
4. Pull down the latch. Hand-tighten the thumbscrew to secure the add-in card to the tray.

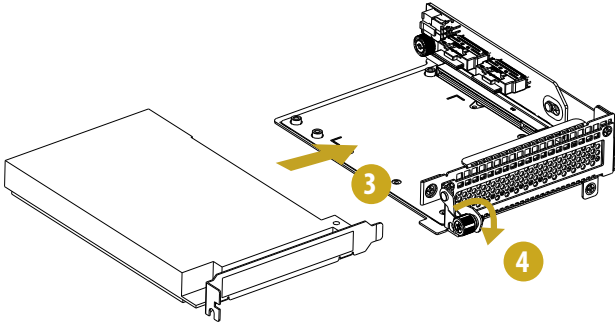

5. Insert the add-in card assembly into the slot.
6. Tighten the screws to secure the assembly to the chassis.
7. Align the fixed position and place the hard drive frame.
8. Tighten the screws on both sides to secure the frame to the chassis.

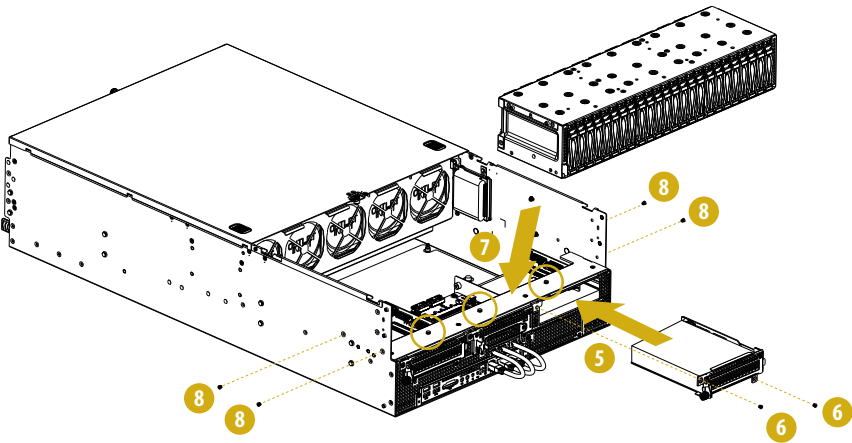

3.6 GPU Card

Installing the GPU Card

1. Remove the screw on the blanking plate.
2. Slide the blanking plate out from above.

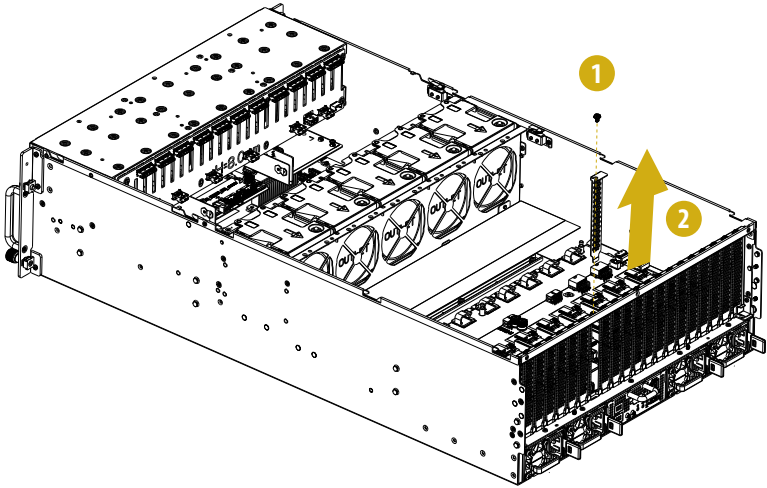

3. Align the slot and insert the GPU card in place.
4. Secure the card to the chassis with the screw.

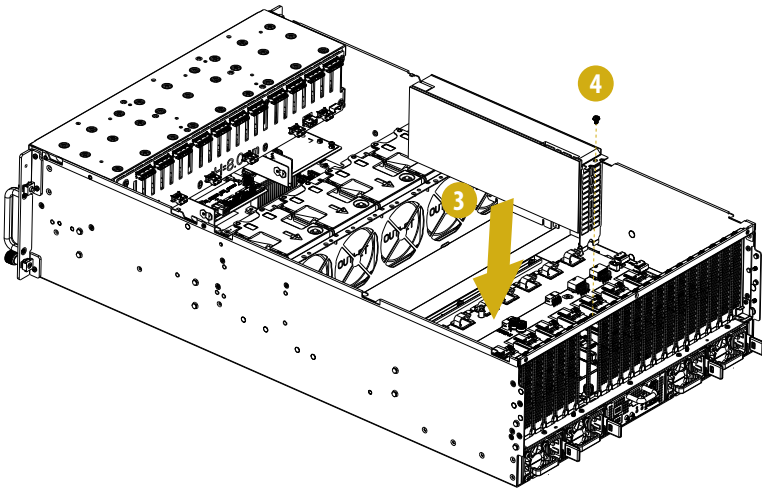

5. Depending on the power connector of GPU card, connect the 12V-2x6 cable pre-installed on the switch board or the 8-pin cable in the accessory box to the GPU card. Make sure the connectors click in place for a secure, full connection.

3.7 OCP Card

Installing the OCP Card

1. Remove the screw securing the slot cover to the chassis.
2. Remove the slot cover.

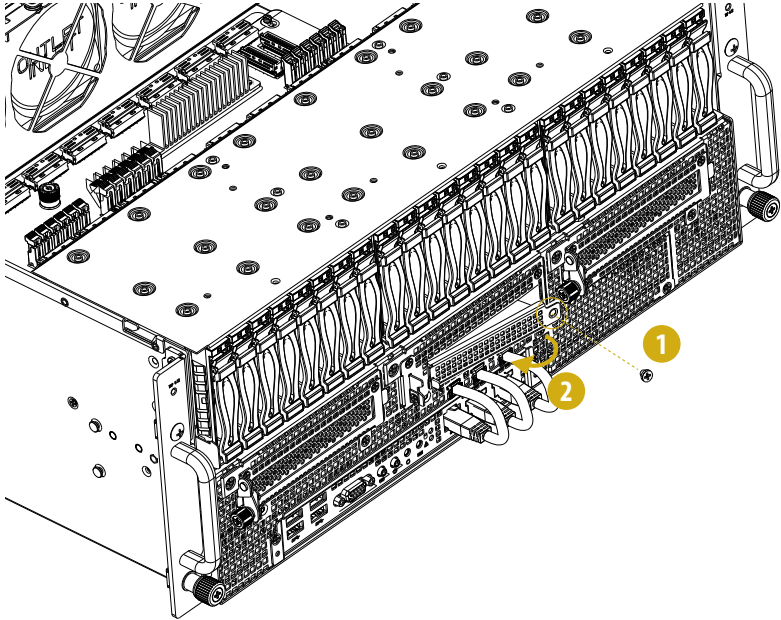

3. Install the OCP card into the slot.
4. Make sure the card is well seated and hand-tighten the thumbscrew on the face plate.

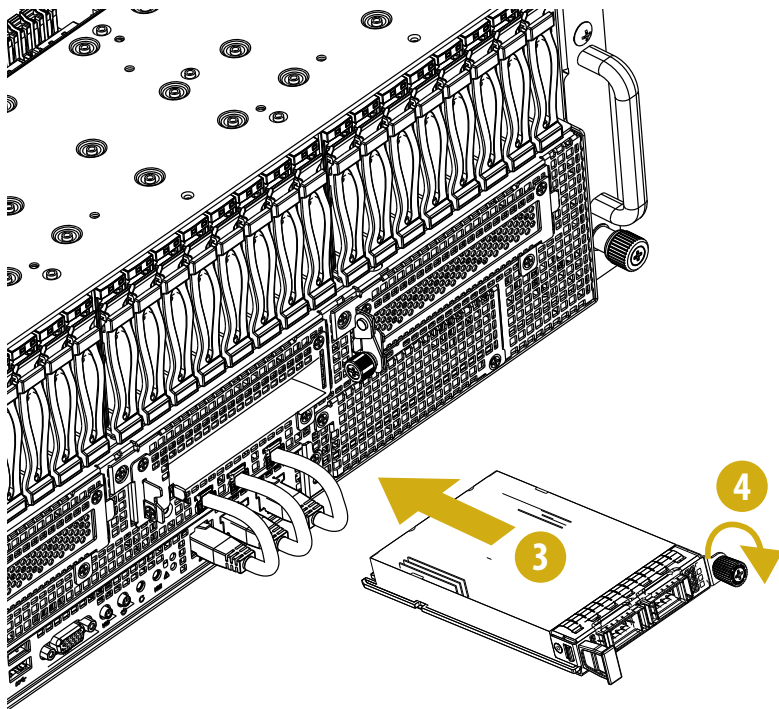

Chapter 4 Server Motherboard (TURIN2D24G-2L+/500W)

4.1 Layout

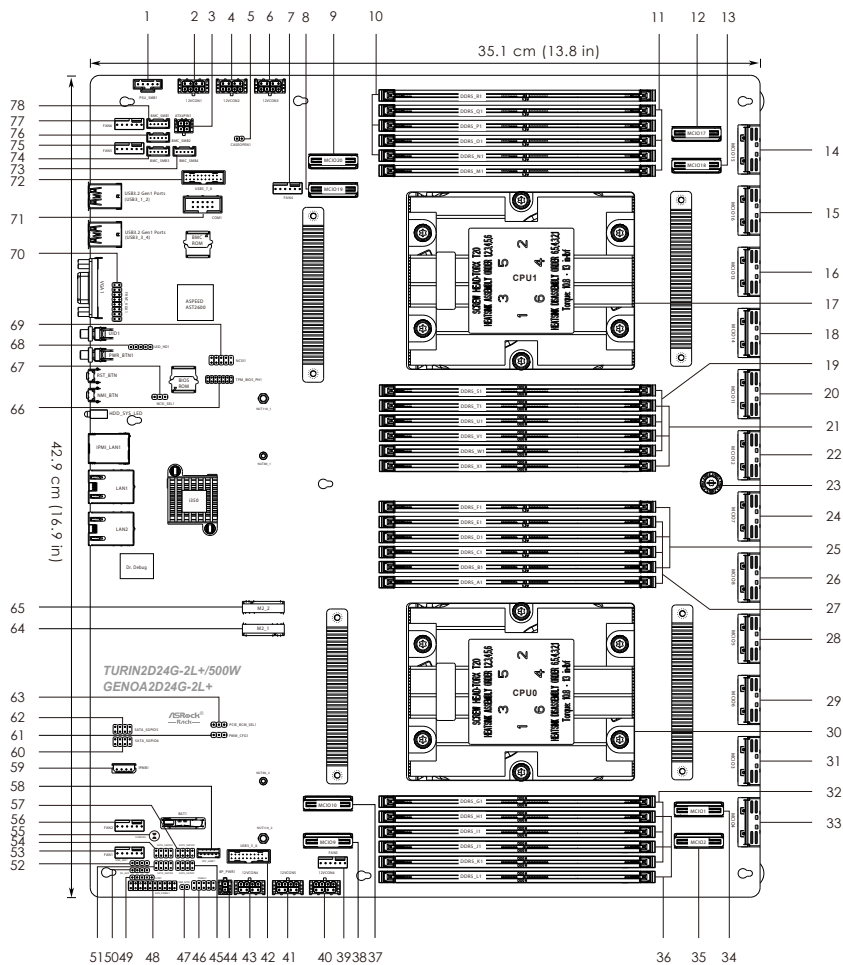

The illustration here is for references only. The actual layout may slightly vary depending on the model and the version used.

No.	Description
1	PSU SMBus Header (PSU_SMB1)
2	ATX 12V Power Connector (12VCON1)
3	Micro-Fit Power Connector (ATX4PIN1)
4	ATX 12V Power Connector (12VCON2)
5	Chassis Intrusion Header (CASEOPEN1)
6	ATX 12V Power Connector (12VCON3)
7	System Fan Connector (FAN4)
8	Mini Cool Edge IO Connector (MCIO19)
9	Mini Cool Edge IO Connector (MCIO20)
10	3 x 288-pin DDR5 DIMM Slots (DDR5_N1, DDR5_P1, DDR5_R1)
11	3 x 288-pin DDR5 DIMM Slots (DDR5_M1, DDR5_O1, DDR5_Q1)
12	Mini Cool Edge IO Connector (MCIO17)
13	Mini Cool Edge IO Connector (MCIO18)
14	Mini Cool Edge IO Connector (MCIO15)
15	Mini Cool Edge IO Connector (MCIO16)
16	Mini Cool Edge IO Connector (MCIO13)
17	AMD Socket SP5 (SM-LGA-6096) (CPU1)
18	Mini Cool Edge IO Connector (MCIO14)
19	3 x 288-pin DDR5 DIMM Slots (DDR5_S1, DDR5_U1, DDR5_W1)
20	Mini Cool Edge IO Connector (MCIO11)
21	3 x 288-pin DDR5 DIMM Slots (DDR5_T1, DDR5_V1, DDR5_X1)
22	Mini Cool Edge IO Connector (MCIO12)
23	Thumbscrew
24	Mini Cool Edge IO Connector (MCIO7)
25	3 x 288-pin DDR5 DIMM Slots (DDR5_B1, DDR5_D1, DDR5_F1)
26	Mini Cool Edge IO Connector (MCIO8)
27	3 x 288-pin DDR5 DIMM Slots (DDR5_A1, DDR5_C1, DDR5_E1)
28	Mini Cool Edge IO Connector (MCIO5)
29	Mini Cool Edge IO Connector (MCIO6)
30	AMD Socket SP5 (SM-LGA-6096) (CPU0)
31	Mini Cool Edge IO Connector (MCIO3)
32	3 x 288-pin DDR5 DIMM Slots (DDR5_G1, DDR5_I1, DDR5_K1)
33	Mini Cool Edge IO Connector (MCIO4)
34	Mini Cool Edge IO Connector (MCIO1)

No.	Description
35	Mini Cool Edge IO Connector (MCIO2)
36	3 x 288-pin DDR5 DIMM Slots (DDR5_H1, DDR5_J1, DDR5_L1)
37	Mini Cool Edge IO Connector (MCIO10)
38	Mini Cool Edge IO Connector (MCIO9)
39	System Fan Connector (FAN3)
40	ATX 12V Power Connector (12VCON6)
41	ATX 12V Power Connector (12VCON5)
42	USB 3.2 Gen1 Header (USB3_5_6)
43	ATX 12V Power Connector (12VCON4)
44	System Power Connector (BP_PWR1)
45	SATA SGPIO Connector (SATA_SGPIO1)
46	System Panel Header (PANEL1)
47	Non Maskable Interrupt Button (NMI_BTN1)
48	Auxiliary Panel Header (AUX_PANEL1)
49	Liquid Crystal Module Header (LCM1)
50	Rear Panel LAN LED (RL_LED)
51	SATA SGPIO Connector (SATA_SGPIO3)
52	IPMI LAN LED Header (IPMI_LED1)
53	System Fan Connector (FAN1)
54	SATA SGPIO Connector (SATA_SGPIO4)
55	Clear CMOS Pad (CLRMO1)
56	System Fan Connector (FAN2)
57	SATA SGPIO Connector (SATA_SGPIO2)
58	Backplane PCI Express Hot-Plug Connector (CPU_HSBP1)
59	Intelligent Platform Management Bus Header (IPMB1)
60	SATA SGPIO Connector (SATA_SGPIO6)
61	PWM Configuration Header (PWM_CFG1)
62	SATA SGPIO Connector (SATA_SGPIO5)
63	PCIE Signal Source Selection Jumper (PCIE_BCM_SEL1)
64	M.2 Socket (M2_1) (Type 2280/22110)
65	M.2 Socket (M2_2) (Type 2280/22110)
66	SPI TPM Header (TPM_BIOS_PH1)
67	NCSI Mode Jumper (NCSI_SEL1)
68	UID Button Header (UID_HD1)

No.	Description
69	NCSI Header (NCSI1)
70	Front VGA Header (FRNT_VGA1)
71	COM Port Header (COM1)
72	USB 3.2 Gen1 Header (USB3_7_8)
73	BMC SMBus Header (BMC_SMB4)
74	BMC SMBus Header (BMC_SMB3)
75	System Fan Connector (FAN5)
76	BMC SMBus Header (BMC_SMB2)
77	System Fan Connector (FAN6)
78	BMC SMBus Header (BMC_SMB1)

4.3 Installing the CPU and Heatsink (LGA 6096 Socket)



1. Before inserting the CPU into the socket, check if the PnP cap is on the socket, if the CPU surface is unclean, or if there are any bent pins in the socket. Do not force to insert the CPU into the socket if above situation is found. Otherwise, the CPU will be seriously damaged.
2. Unplug all power cables before installing the CPU.

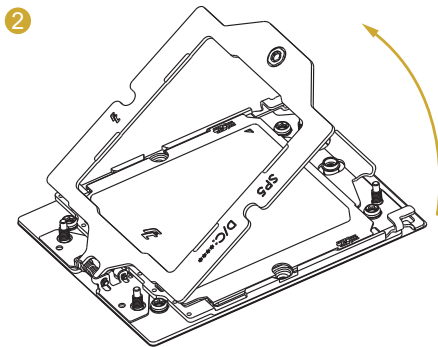
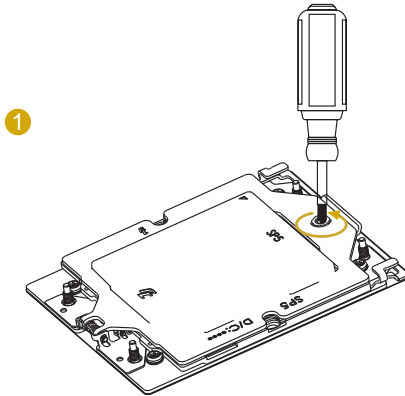

3

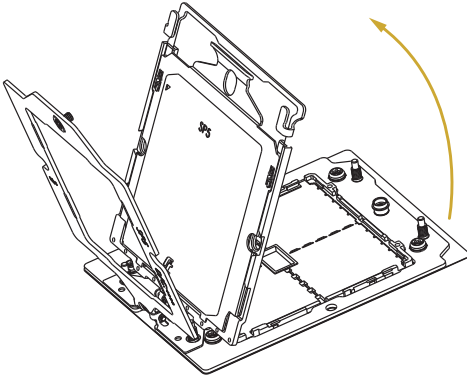

4

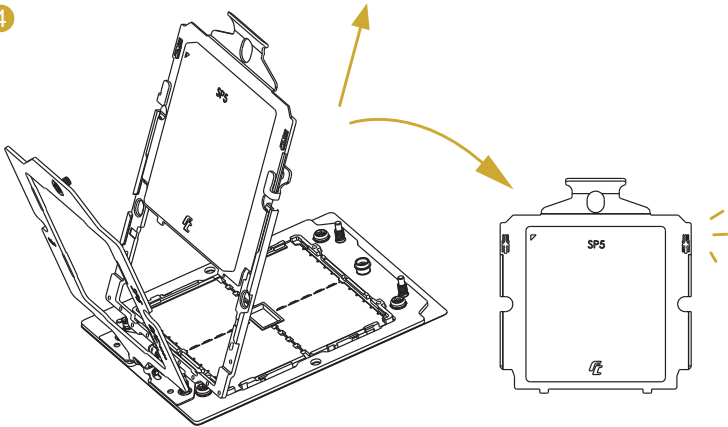

5

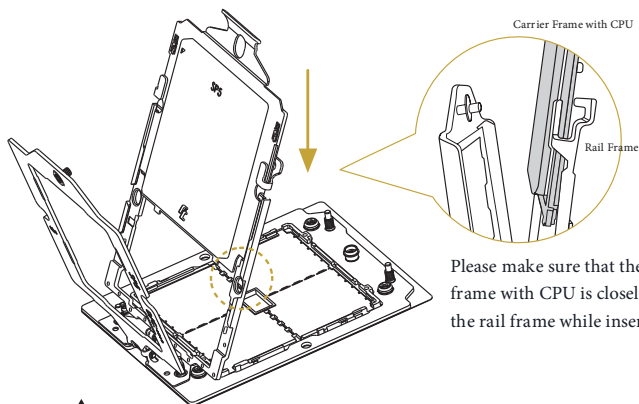

Please make sure that the carrier frame with CPU is closely attached to the rail frame while inserting it.



Install the carrier frame with CPU. Don't separate them.

6

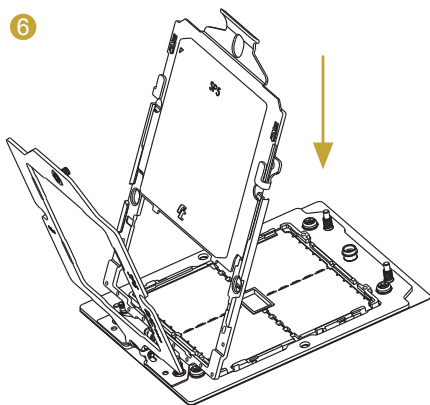

7

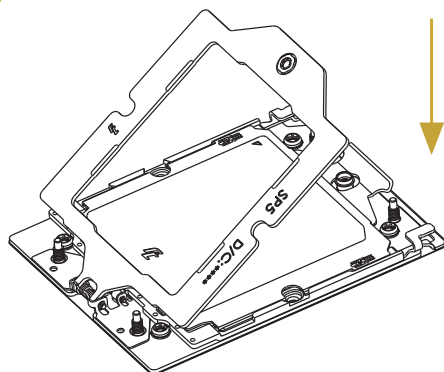

8

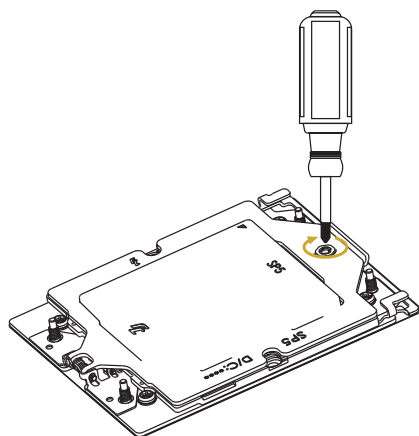

9

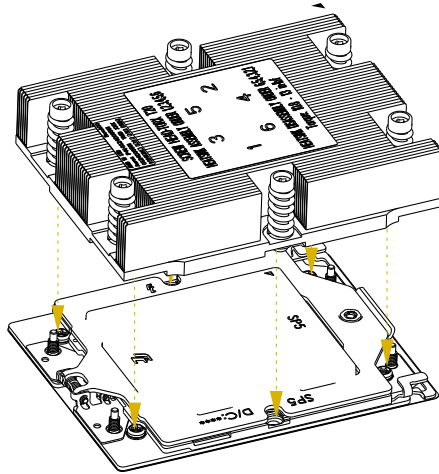

10

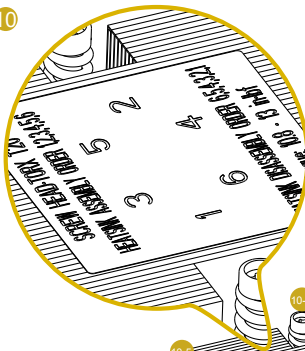

Set the torque wrench to 10.8-13.0 in.-lb.
One fourth a turn each time.

Tighten the screws in a sequential order
1 > 2 > 3 > 4 > 5 > 6.
Loosen the screws in a reverse order.

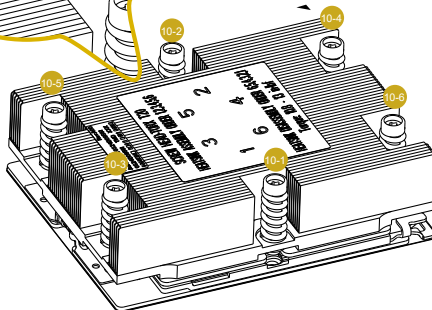

4.4 Installing the Memory Modules (DIMM)



The DIMM only fits in one correct orientation. It will cause permanent damage to the server motherboard and the DIMM if forcing the DIMM into the slot at incorrect orientation. For more information about DIMM installation, refer to the server motherboard user manual.

1

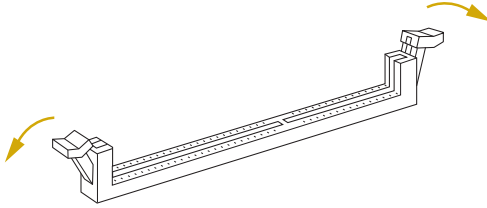

2

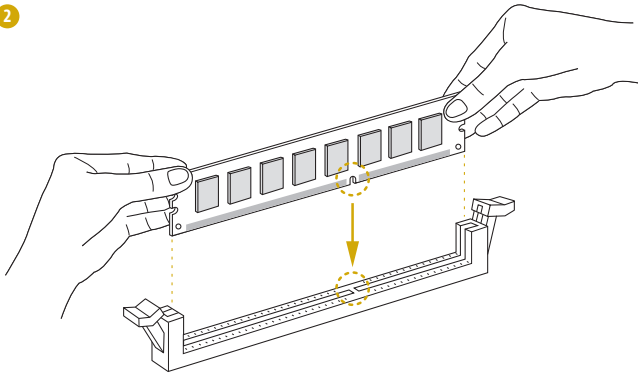

3

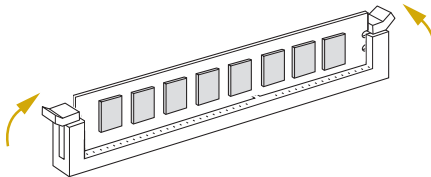

Appendix

Installing the Server in a Rack

This section describes how to rackmount the server with slide rail assembly.



The rails installation instructions in this manual are example only, the actual rail assembly procedure may differ slightly.

The rail assembly consists of outer, middle and inner rail.

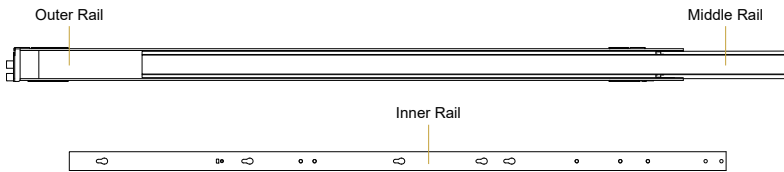

Some slide rails are labeled with either L or R, please identify prior to rail installation. Install the rail labeled with L on the left side of rack, and the rail labeled with R on the right side.

1. Take out the inner rail and slide the middle rail back.

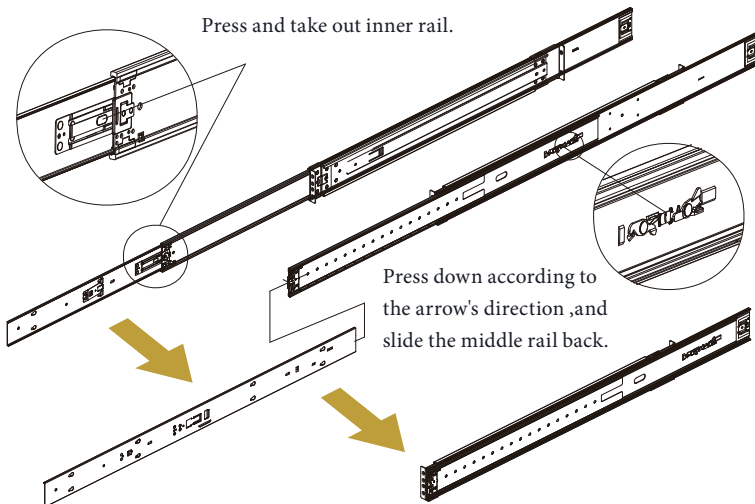

2. Install the inner rail onto the chassis.

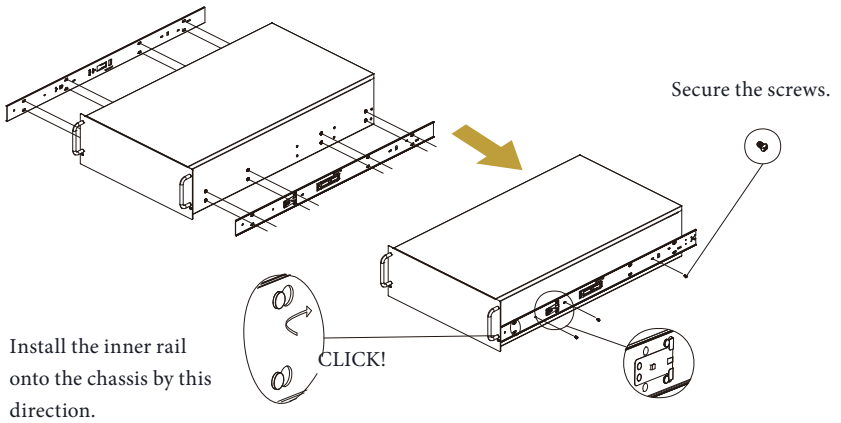

3. Install the outer rail and bracket onto the rack.

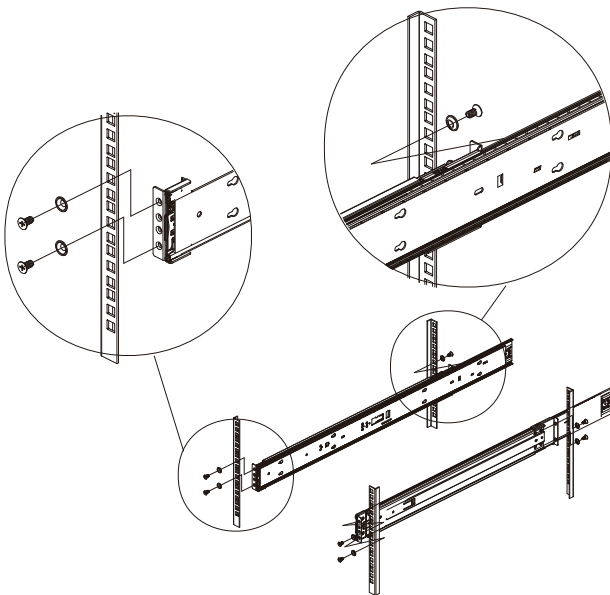

4. Chassis installation: Make sure the ball-bearing retainer is at the front of middle rail, then aim and push the inner rail (chassis installed) into the middle/outer rail.

CAUTION!

Verify ball bearing retainer is locked forward.

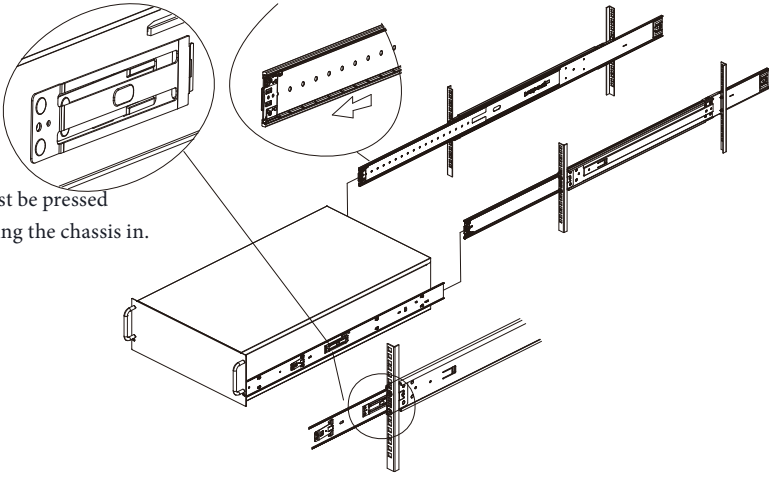

The tab must be pressed when pushing the chassis in.

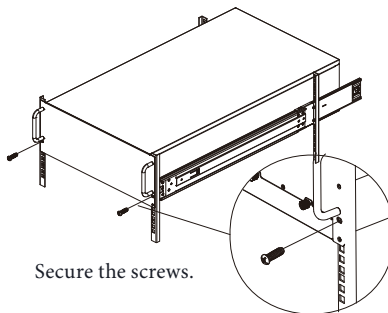

Secure the screws.

Contact Information

Contact ASRock Rack or want to know more about ASRock Rack, you're welcome to visit ASRock Rack's website at <http://www.asrockrack.com>; or contact the dealer for further information. For technical questions, please submit a support request form at <https://event.asrockrack.com/tsd.asp>

ASRock Rack Incorporation

e-mail: ASRockRack_sales@asrockrack.com

ASRock Rack EUROPE B.V.

Bijsterhuizen 11-11
6546 AR Nijmegen
The Netherlands
Phone: +31-24-345-44-33

ASRock Rack America, Inc.

4331 Eucalyptus Ave, Chino, CA 91710 U.S.A.
Phone: +1-909-590-8308
Fax: +1-909-590-1026